

Plunger Pumps

Please read and save these instructions. Read carefully before attempting to assemble, install, operate or maintain the product described. Protect yourself and others by observing all safety information. Failure to comply with instructions could result in personal injury and/or property damage! Retain instructions for future reference.

Description

This plunger pump will pump up to 2.5 GPM at 2500 PSI. It spins at 3400 RPM in a direct drive system coupled with a gasoline engine. The matching flange provides convenient connection to most 3/4" shaft 3.5 - 6.5 HP engines. The hollow shafted pump includes a built-in pressure control valve, and chemical injection system.

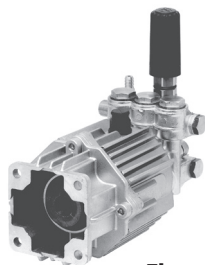

Figure 1 - SJV-F7

SJV 3400 rpm D Version

Model	Max GPM	Max PSI
SJV2.5G24D-F7	2.5	2500
SJV2.5G25D-F7	2.5	2500
SJV2.5G27D-F7	2.5	2700
SJV3G27D-F7	3.0	2700
SJV3G27D-EZ	3.0	2700

SJW 3400 rpm D Version

Model	Max GPM	Max PSI
SJW3G25D-F27	3.0	2500

XJV 3400 rpm E Version 5/8"

Model	Max GPM	Max PSI
XJV2G15E-F8	2.0	1450
XJV3G20E-F8	3.0	2000

XJW 3400 rpm D Version

Model	Max GPM	Max PSI
XJW2G25D-F27*	2.0	2500
XJW2.5G25D-F27	2.5	2500
XJW3G25D-F27	3.0	2500



Figure 2 - SJW-F27 & XJW-F27

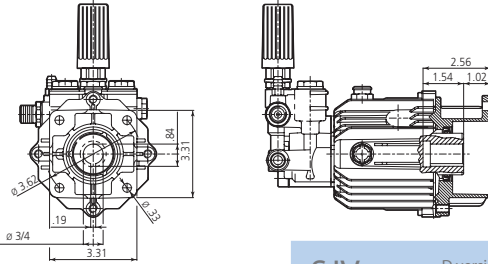

Figure 3 - XJV-F8

Special Note: Use only AR64545 for the XJ/SJ/BK Series pumps only: Do NOT change oil. Use oil only to add if low. This oil is a specially formulated synthetic with special additives for the demands of the XJ, SJ and BK pump series. No other oil is factory approved for these pumps, and could result in pump failure.

SJV

D version + F7
Hollow shaft pump ϕ 3/4"



SJV

D version + F7
Hollow shaft pump ϕ 3/4"

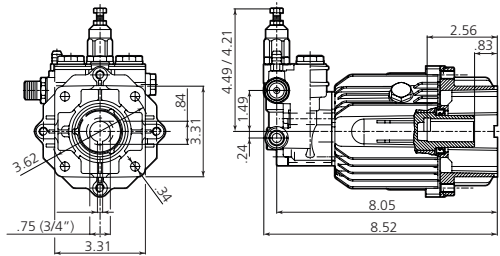

SJW

D version + F27
Hollow shaft pump ϕ 7/8"

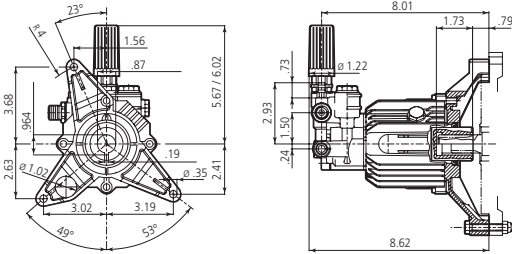

XJV

E version + F8
Hollow shaft pump ϕ 5/8"

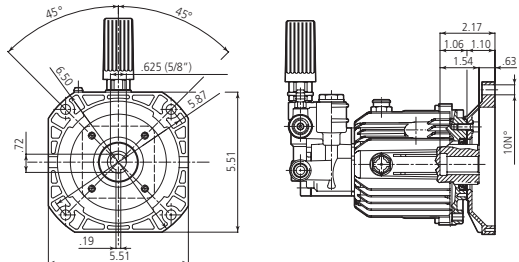

SPRAY NOZZLE CHART

Nozzle #	1000	1200	1400	1600	1800	2000	2200	2400	2600	2800	3000	3200	3400	3600	3700	4000	4200	4400	4600	4800	5000
	PSI	PSI	PSI	PSI	PSI	PSI	PSI	PSI	PSI	PSI	PSI	PSI	PSI	PSI	PSI	PSI	PSI	PSI	PSI	PSI	PSI
2.0	1.00	1.10	1.18	1.26	1.34	1.41	1.48	1.55	1.61	1.67	1.73	1.79	1.84	1.90	1.92	2.00	2.05	2.10	2.14	2.19	2.40
2.25	1.13	1.23	1.33	1.42	1.51	1.59	1.67	1.74	1.81	1.88	1.95	2.01	2.07	2.13	2.16	2.25	2.31	2.36	2.41	2.46	2.52
2.5	1.25	1.37	1.48	1.58	1.68	1.77	1.85	1.94	2.02	2.09	2.17	2.24	2.30	2.37	2.40	2.50	2.56	2.62	2.68	2.74	2.80
2.75	1.38	1.51	1.63	1.74	1.84	1.94	2.04	2.13	2.22	2.30	2.38	2.46	2.54	2.61	2.64	2.75	2.82	2.88	2.95	3.01	3.07
3.0	1.50	1.64	1.77	1.90	2.01	2.12	2.22	2.32	2.42	2.51	2.60	2.68	2.77	2.85	2.89	3.00	3.07	3.15	3.22	3.29	3.35
3.25	1.63	1.78	1.92	2.06	2.18	2.30	2.41	2.52	2.62	2.72	2.81	2.91	3.00	3.08	3.13	3.25	3.33	3.41	3.49	3.56	3.63
3.5	1.75	1.92	2.07	2.21	2.35	2.47	2.60	2.71	2.82	2.93	3.03	3.13	3.23	3.32	3.37	3.50	3.59	3.67	3.75	3.83	3.91
4.0	2.00	2.19	2.37	2.53	2.68	2.83	2.97	3.10	3.22	3.35	3.46	3.58	3.69	3.79	3.85	4.00	4.10	4.20	4.29	4.38	4.47
4.5	2.25	2.46	2.66	2.85	3.02	3.18	3.34	3.49	3.63	3.76	3.90	4.02	4.15	4.27	4.33	4.50	4.61	4.72	4.83	4.93	5.03
5.0	2.50	2.74	2.96	3.16	3.35	3.54	3.71	3.87	4.03	4.18	4.33	4.47	4.61	4.74	4.81	5.00	5.12	5.24	5.36	5.48	5.59
5.5	2.75	3.01	3.25	3.48	3.69	3.89	4.08	4.26	4.43	4.60	4.76	4.92	5.07	5.22	5.29	5.50	5.64	5.77	5.90	6.02	6.15
6.0	3.00	3.29	3.55	3.79	4.02	4.24	4.45	4.65	4.84	5.02	5.20	5.37	5.53	5.69	5.77	6.00	6.15	6.29	6.43	6.57	6.71
6.5	3.25	3.56	3.85	4.11	4.36	4.60	4.82	5.03	5.24	5.44	5.63	5.81	5.99	6.17	6.25	6.50	6.66	6.82	6.97	7.12	7.27
7.0	3.50	3.83	4.14	4.43	4.70	4.95	5.19	5.42	5.64	5.86	6.06	6.26	6.45	6.64	6.73	7.00	7.17	7.34	7.51	7.67	7.83
7.5	3.75	4.11	4.44	4.74	5.03	5.30	5.56	5.81	6.05	6.27	6.50	6.71	6.91	7.12	7.21	7.50	7.69	7.87	8.04	8.22	8.39
8.0	4.00	4.38	4.73	5.06	5.37	5.66	5.93	6.20	6.45	6.69	6.93	7.16	7.38	7.59	7.69	8.00	8.20	8.39	8.58	8.76	8.94
8.5	4.25	4.66	5.03	5.38	5.70	6.01	6.30	6.58	6.85	7.11	7.36	7.60	7.84	8.06	8.18	8.50	8.71	8.91	9.12	9.31	9.50
9.0	4.50	4.93	5.32	5.69	6.04	6.36	6.67	6.97	7.26	7.53	7.79	8.05	8.30	8.54	8.66	9.00	9.22	9.44	9.65	9.86	10.06
9.5	4.75	5.20	5.62	6.01	6.37	6.72	7.05	7.36	7.66	7.95	8.23	8.50	8.76	9.01	9.14	9.50	9.73	9.96	10.19	10.41	10.62
10.0	5.00	5.48	5.92	6.32	6.71	7.07	7.42	7.75	8.06	8.37	8.66	8.94	9.22	9.49	9.62	10.00	10.25	10.49	10.72	10.95	11.18
11.0	5.50	6.02	6.51	6.96	7.38	7.78	8.16	8.52	8.87	9.20	9.53	9.84	10.14	10.44	10.58	11.00	11.27	11.54	11.80	12.05	12.30
12.0	6.00	6.57	7.10	7.59	8.05	8.49	8.90	9.30	9.67	10.04	10.39	10.73	11.06	11.38	11.54	12.00	12.30	12.59	12.87	13.15	13.42
12.5	6.25	6.85	7.40	7.91	8.39	8.84	9.27	9.68	10.08	10.46	10.83	11.18	11.52	11.86	12.02	12.50	12.81	13.11	13.40	13.69	13.98
13.0	6.50	7.12	7.69	8.22	8.72	9.19	9.64	10.07	10.48	10.88	11.26	11.63	11.99	12.33	12.50	13.00	13.32	13.63	13.94	14.24	14.53

Gallons Per Minute

Plunger Pumps

Formulas

Nozzles:

Impact Force (lbs.) = .0526 x GPM x $\sqrt{\text{PSI}}$

Nozzle # = $\text{GPM} \times \frac{4000}{\sqrt{\text{PSI}}}$

$\text{GPM} = \text{Nozzle \#} \times \frac{\text{PSI}}{\sqrt{4000}}$

$\text{PSI} = (\text{GPM}/\text{Nozzle \#})^2 \times 4000$

Horse Power:

$\frac{\text{GPM} \times \text{PSI}}{1714} = \text{Hydraulic HP}$

$\frac{\text{GPM} \times \text{PSI}}{1457} = \text{EBHP}$

$\frac{\text{EBHP} \times 1457}{\text{PSI}} = \text{GPM}$

$\frac{\text{EBHP} \times 1457}{\text{GPM}} = \text{PSI}$

HP loss due to altitude = 3% per 1000 FT above sea level

Pump Speed and Flow:

$\frac{\text{Rated GPM}}{\text{Rated RPM}} = \frac{\text{Desired GPM}}{\text{Desired RPM}}$

$\frac{\text{Motor Pulley } \varnothing}{\text{Pump RPM}} = \frac{\text{Pump Pulley } \varnothing}{\text{Motor RPM}}$

Conversions

Gallons x 3.785412 = Liters

Gallons x 128 = Oz.

PSI x .06896 = Bar

Bar x 14.5038 = PSI

1 inches = 25.4 millimeters

Liters x .2642 = Gallons (US)

Ft. Lbs. x 1.356 = Newton Meters

Inch Lbs. x .11298 = Newton Meters

Newton Meters x .737562 = Ft. Lbs. (force)

Newton Meters x 8.85 = In. Lbs. (force)

Temperature = $1.8(\text{C}^\circ + 17.78) = \text{F}^\circ$, $555(\text{F}^\circ - 32) = \text{C}^\circ$

1 U.S. Gallon of freshwater = 8.33 lbs.

1 PSI = 2.31 feet of water

1 PSI = 2.04 inches of mercury

1 Foot of water = .433 PSI

1 Foot of water = .885 inches of mercury

1 Meter of water = 3.28 feet of water

Kilograms x 2.2 = Lbs.

General Safety Information



WARNINGS

Gasoline Drive Pumps

 The pump is designed to pump non-flammable or non-explosive fluids.

These pumps are intended to pump clean filtered water only.

 Do not operate in or around an explosive environment.

  Always wear safety glasses or goggles and appropriate clothing.

Do not alter the pump from the

 manufacturers design.

Do not allow children to operate the pump.



Never point the high-pressure discharge at a person, any part of the body or animals.



Do not operate gasoline engines in a confined area; always have adequate ventilation.

Do not exceed the pump specifications

 in speed or pressure.

Plunger Pumps

General Safety Information (continued)



Maximum water temperature is 140°F.

All positive displacement plunger pumps must have a safety relief valve installed on the discharge side of the pump, this valve could be either an unloader or regulator and must be of adequate flow and pressure for the pump. (This pump has an unloader already built in).

Adequate protective guards must cover all moving parts. Perform routine maintenance on the pump and components.

Use only components that are rated for the flow and pressure of the pump, this would include hose, fittings, safety valves, spray guns etc.

Special Features

Wet End

Manifold: Forged Brass: Strength and no porosity – long life. Higher hydrostatic pressures – safety.

Unloader: Integral trap pressure, fixed chemical injector. Simple repair using a cartridge replacement kit. **Bolts:** Three bolts, 10mm, grade 8.8.

Valves: Ultra Form Cages: Durable, strong, and long life. Unique inlet valve configuration: the valve cage incorporates the high pressure packing head ring. **Poppets, Seat and Spring:** 303 and 400 series stainless steel. **Valve Caps:** Machined brass for greater

strength.

Packing and Plungers: High Pressure Packing: “V” style (D-1) Buna-N (cotton duct weave base) strong and tightens under load. Continuously lubricating for extended life, self lubricating packing/Plunger guide support ring.

Low-Pressure Seals: “U” cup double lip Buna-N for a good positive seat.

Support and Guides: Machined brass, 1-piece construction to assure proper plunger alignment, maximize packing and seal life. **Plungers:** Coated ceramic stainless steel, strong and durable. The pump includes a plunger shoe to distribute the additional plunger load.

Drive End

Bearings: Angular contact ball bearing stabilizes the crankshaft and one thrust needle bearing absorbs the plunger load and assures long radial plate life. All of the thrust plates are made of heat treated hardened steel for extended life.

Crankcase: Precision die-cast, large cooling fins and anodized for maximum heat dissipation. Sight glass, fill and drain plugs.

Rear Cover: Precision die-cast, O-ring sealed. The housing retains the crankshaft bearing, oil seal and rear wobble plate bearing support washer.

Crankshaft/Wobble Plate: Precision die-cast to assure proper stroke, duration and alignment.



Plunger Pumps

Special Features (continued)

Oil Seals and O-rings: All are constructed of Buna-N rubber. The oil seals have stainless steel garter springs to assure constant tension on the sealing surface.

Oil Capacity: 4.5 oz.

Extra Features

Dyno Proven: All pumps are dyno tested to assure the theoretical design meets the actual design.

Valve Design: Each pump series has a valve design that optimizes its highest efficiency.

Wet End Repair: Very simple no special tools required.

Mounting Flanges: Gasoline SAE J609a flange. Refer to breakdown.

Design: Using advanced fluid handling design programs. Overall pump efficiency is increased.

Installation

1. Install the shaft key into the keyway and apply a light coating of anti-seize on the engine shaft and key.
2. Align the two key ways and push the pump completely onto the engine.
3. Install all four (4) bolts and tighten evenly. (See figure 4)
4. Remove the red shipping

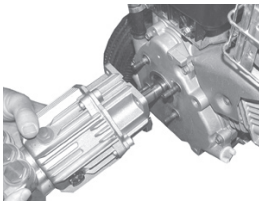

Figure 4

oil cap and install the black crankcase vent cap. (See figure 5)

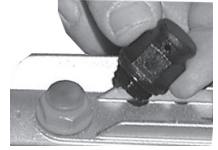

Figure 5

5. Install the appropriate water inlet and discharge fittings.
6. Connect the water supply hose and high-pressure discharge hose/spray gun.
7. Turn on the water supply.
8. Open the spray gun to purge the system of any air.
9. Start the engine.
10. If necessary adjust the engine speed and unloader valve.

Unloader Adjustment Steps

Please follow these easy steps to adjust the pressure:

Step 1: Remove black cap (See figure 6 ref. no. 46)

Step 2: Loosen nut (See figure 6 ref. no. 3) with 10mm wrench.

Step 3: Turn brass (See figure 6 ref. no. 4) clockwise until it stops.

Step 4: Install a liquid filled pressure gauge in the discharge line. The gauge should be placed between the unloader discharge fitting and high-pressure hose.

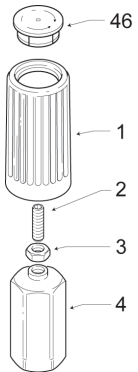

Figure 6

Plunger Pumps

Installation (Continued)

NOTE: The fittings used must be rated for the pressure of the unit.

Step 5: Start pump, watch pressure gauge and turn (See figure 6 ref. no. 2) using 3mm hex clockwise until recommended/ rated pressure is obtained. Line pressure will be approximately 200 psi less than actual head pressure. **DO NOT** set line pressure to rated.

Step 6: Release trigger and make sure there is minimal spike (200-300 psi) (Repeat this step two or three times).

Step 7: Tighten nut (See figure 4 ref. no. 3) down against (See figure 6 ref. no. 4).

Step 8: Replace black cap (See figure 6 ref. no. 46)

NOTE: Now pressure can be decreased by turning black knob counterclockwise, but the pressure cannot be increased to a rating higher than was set. We recommend this procedure be done by a qualified high pressure pump service technician. Failure to properly adjust can cause serious damage to equipment and body.

Failure to use a pressure gauge may cause the pump to be set at a pressure that exceeds its specifications. Resulting in injury or pump damage.

Service Pumps

Servicing the Valves

Discharge Valves:

Disassembly:

1. Remove the valve cap (See figure 7).
2. Inspect the valve cap O-ring for any damage, replace if necessary.
3. Using a needle nose pliers remove the valve. (See figure 8)
4. Use a small probe to move the poppet up and down to assure that it is functioning properly.
5. Inspect for any debris that may be lodged between the poppet and seat.
6. Remove the valve seat O-ring and inspect for any damage.



Figure 7



Figure 8

Assembly:

1. Install the valve seat O-ring squarely into the bottom of the manifold. (See figure 9)
2. Insert the valve assembly squarely into the port pushing it into the O-ring.

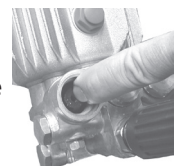

Figure 9

Plunger Pumps

Service Pumps (Continued)

3. Install the valve cap and torque to the proper specifications. (See figure 10).



Figure 10

Inlet Valves:

Disassembly:

1. Remove the manifold.
2. Remove low pressure seals, insert screwdriver under seal lip and lift up. (See figure 11)



Figure 11

3. Using a reversible pliers, carefully remove the packing retainers (plunger guides). (See figure 12)



Figure 12

- NOTE:** You do not want to damage these so they can be reused if not worn.

4. Remove the high-pressure packing by pulling straight out with your finger. (See figure 13)



Figure 13

5. Pull out the valve cage/head ring assembly, valve poppet, spring and O-ring. (See figure 14)



Figure 14

6. Inspect for any debris or damage.

7. Remove the valve O-ring.

Assembly:

1. Install the valve seat O-ring squarely into the bottom of the manifold. (See figure 15)



Figure 15

2. Insert the valve assembly and push squarely into the O-ring. (See figure 16)



Figure 16

3. Install the high-pressure packing by placing it into the cylinder at an angle and then pushing into place.

NOTE: The point of the "V" or flat side of the packing is pointed at you.

4. Lubricate the packing retainer O-ring with a light film of oil and install it into the cylinder.



Figure 17

5. Push it completely into place. (See figure 17)

NOTE: The O-ring will seat just inside the manifold and you will hear a slight pop.

6. Insert the low pressure seal by placing it into the cylinder in at an angle and pushing it into place. (See figure 18)



Figure 18

Plunger Pumps

Service Pumps (Continued)

- Put a thin coat of oil on the plungers and packings. (See figure 19)

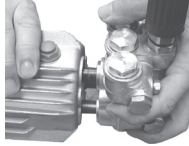

Figure 19

- Carefully install the manifold and torque the bolt to the proper specifications. (See figure 20)



Figure 20

Valve life is dependant on many variables. Hard water, cavitation, corrosion, chemicals and equipment care. The valves are a wear item and need periodic replacement. Worn O-rings or damaged valves will cause pressure loss and pulsations.

Servicing the Packings/Seals

Packings:

Disassembly:

To access the water seals for inspection or replacement, you will first need to remove the head of the pump.

NOTE: It is important to make note of the order in which the components of the packing stack are arranged and facing during disassembly.

- Remove the head bolts.
- Insert small pry bars between the

head and body at opposite corners and apply pressure down on one pry bar and up on the other pry bar. (See figure 21)



Figure 21

- Lift the head up and away from the body. (See figure 22)

NOTE: The packing stacks will not always stay in the head of the pump when it is removed. Sometimes one or more components of the packing stack will come out of the head and stay on the plunger.

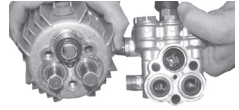

Figure 22

- To remove any components that stay on the plungers simply twist back and forth while pulling up. (See figure 23)



Figure 23

- Remove low pressure seals insert screwdriver under seal lip and lift up. (See Figure 24)

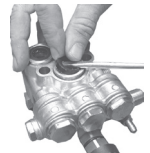

Figure 24

- Remove the piston guides from the head by using a reverse plier (preferably rubber coated) inserted into the center of the piston guide.
- Use a back and forth twisting motion while pulling up (clockwise and counterclockwise).

Plunger Pumps

Service Pumps (Continued)

- Another method is to use a two-prong slide hammer puller. Insert the prongs into the piston guide allowing the prongs to grab under the support ring then use the slide hammer to pull the packing stack up and out of the head. (See Figure 25)



Figure 25

- NOTE:** Damage to the piston guides and or the seals may occur during removal. Inspect carefully before reusing any components of the packing stack.

- Remove the high-pressure packing by pulling straight out with your finger. (See Figure 26)



Figure 26

Assembly:

- Install the high-pressure seal into the head.

NOTE: It should fit snugly. The packing support is part of the valve cage.

- Place the high-pressure seal at an angle and work it into the cylinder. (See Figure 27)



Figure 27

NOTE: The point of the "V" or flat side of the packing is pointed at you.

- Lubricate the packing retainer

O-ring with a light film of oil and install it into the cylinder. Push it completely into place. (See Figure 28)



Figure 28

NOTE: The O-ring will seat just inside the manifold and you will hear a slight pop.

- Insert the low-pressure seal by placing it into the cylinder in at an angle and pushing it into place. (See Figure 29)



Figure 29

- Put a thin coat of oil on the plungers and packings. (See Figure 30)



Figure 30

- Carefully install the manifold and torque the bolt to proper specifications. (See Figure 31)



Figure 31

Valve life is dependant on many variables. Hard water, cavitation, corrosion, chemicals and equipment care. The valves are a wear item and need periodic replacement. Worn O-rings or damaged valves will cause pressure loss and pulsations.

NOTE: Water seals are wear items. Life of the seals is dependent on many factors. Water seals should be replaced when water leak or a loss of performance is noticed. Prompt

Service Pumps (Continued)

Plunger Pumps

replacement of worn seals will insure peak operating performance and trouble free operation. The water seals and their respective components sometimes referred to as the packing stack, will vary slightly between models. But the constant between models is that the packing stack will consist of the following items:

Piston Guides - which usually house the low-pressure seal

Low-Pressure Seals

Piston Guide O-rings

High-Pressure Seals

Support Rings

Torque Ratings Inch Pounds (ft. lbs.)

Head	443 (37)
Valve Cap	443 (37)

Oil - AR64545 - Container is 4.5 fluid ounces. Specially formulated for the demands of the SJ and XJ series pump. See parts breakdown.

NOTE: No other oil is factory approved for this pump. Using any other oil may result in Drive End Damage.

Winter or Long Time Storage

1. Drain all of the water out of the pump.
2. Run a 50% solution of a RV or non-toxic/biodegradable antifreeze through the pump.
3. Flush the pump with fresh water before the next use.
4. In freezing conditions failure to do this may cause internal pump damage.
5. For long periods of storage in non-freezing areas the solution will keep the seals and O-rings lubricated.

Troubleshooting

Symptom	Possible Cause(s)	Corrective Action
Oil Leak Between Crankcase and Pumping Section	Worn rod oil seals	Replace crankcase piston rod seals
Frequent or Premature Failure of the Packing	<ol style="list-style-type: none"> 1. Cracked, damaged or worn plunger 2. Overpressure to inlet manifold 3. Material in the fluid being pumped 4. Excessive pressure and/or temperature of fluid being pumped 5. Running pump dry 	<ol style="list-style-type: none"> 1. Replace plungers 2. Reduce inlet pressure 3. Install proper filtration on pump inlet plumbing 4. Check pressures and fluid inlet temperature; be sure they are within specified range 5. Do not run pump without water
Pump Runs but Produces no Flow	Pump is not primed	Flood suction then restart pump
Pump Fails to Prime	Air is trapped inside pump	Disconnect discharge hose from pump. Flood suction hose, restart pump and run pump until all air has been evacuated
Pump Loses Prime, Chattering Noise, Pressure Fluctuates	<ol style="list-style-type: none"> 1. Air leak in suction hose or inlet 2. Clogged suction strainer 	<ol style="list-style-type: none"> 1. Remove suction line and inspect it for a loose liner or debris lodged in hose. Avoid all unnecessary bends. Do not kink hose 2. Clean strainer
Low Pressure at Nozzle	<ol style="list-style-type: none"> 1. Unloader valve is bypassing 2. Incorrect or worn nozzle 3. Worn packing or valves 	<ol style="list-style-type: none"> 1. Make sure unloader is adjusted properly and bypass seat is not leaking 2. Make sure nozzle is matched to the flow and pressure of the pump. If the nozzle is worn, replace 3. Replace packing or valves
Pressure Gauge Fluctuates	<ol style="list-style-type: none"> 1. Valves worn or blocked by foreign bodies 2. Packing worn 	<ol style="list-style-type: none"> 1. Clean or replace valves 2. Replace packing
Low Pressure	<ol style="list-style-type: none"> 1. Worn nozzle 2. Belt slippage 3. Air leak in inlet plumbing 4. Relief valve stuck, partially plugged or improperly adjusted valve seat worn 5. Worn packing. Abrasive 	<ol style="list-style-type: none"> 1. Replace with nozzle of proper size 2. Tighten or replace with correct belt 3. Disassemble, reseal and reassemble 4. Clean and adjust relief valve; check for worn or dirty valve seats 5. Install proper filter.

Troubleshooting

Symptom	Possible Cause(s)	Corrective Action
Low Pressure (cont)	in pumped in cavitation. Inadequate water	Suction at inlet manifold must be limited to lifting less than 20 feet of water or 8.5 psi vacuum
	6. Worn inlet, discharge valve blocked or dirty Inlet restrictions and/or air leaks.	6. Replace inlet and discharge valve Clean out foreign material.
Pump Runs Extremely Rough, Pressure Very Low	Stuck inlet or discharge valve	Replace worn valves
Water Leakage from Under Manifold. Slight Leak	Worn packing or cracked plunger	Install new packing or plunger
Oil Leaking in the Area of Crankshaft	1. Worn crankshaft seal or improperly installed oil seal O-ring 2. Bad bearing	1. Remove oil seal retainer and replace damaged O-ring and/or seals 2. Replace bearing
Excessive Play in the End of the Crankshaft Pulley	Worn main bearing from excessive tension on drive belt	Replace crankcase bearing and/or tension drive belt
Water in Crankcase	1. Humid air condensing into water inside the crankcase 2. Worn packing and/or cracked plunger	1. Change oil intervals 2. Replace packing. Replace plunger
Loud Knocking Noise in Pump	1. Cavitation or sucking air 2. Pulley loose on crankshaft 3. Broken or worn bearing	1. Check water supply is turned on 2. Check key and tighten set screw 3. Replace bearing

SJV & XJV 3400 RPM

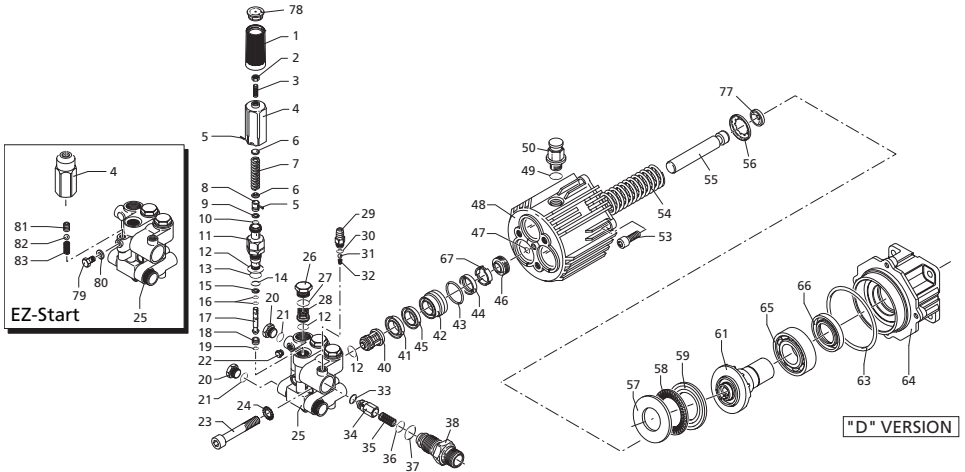

Repair Kits

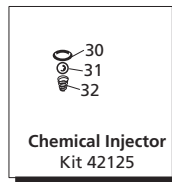
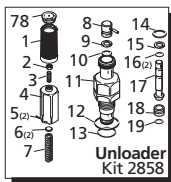
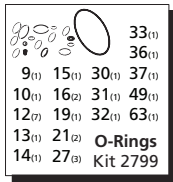
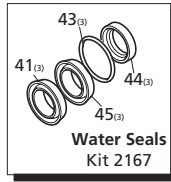
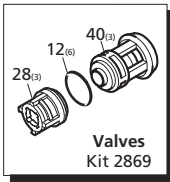

Pos.	Code	Description	Qty.	Pos.	Code	Description	Qty.
1	1981780	Knob	1	38	1270141	Injector adapter	1
2	1980300	Nut	1	40	1989050	Inlet valve	3
3	1980470	Adjusting screw	1	41	1342761	Gasket	3
4	1980390	Handle insert	1	42	1981570	Piston guide	3
4	1980540	Handle insert - EZ Start	1	43	770260	O-Ring $\varnothing 23.52 \times 1.78$	3
5	1080070	Pin	2	44	1260440	Gasket	3
6	1980220	Plate spring	2	45	1981580	Ring	3
7	1271070	Spring	1	46	1980410	Oil seal	3
8	1080041	Upper piston	1	47	770090	O-Ring $\varnothing 5.28 \times 1.78$	1
9	1080401	Back-up ring	1	48	1983050	Pump housing	1
10	1080250	O-Ring $\varnothing 7.66 \times 1.78$	1	49	740290	O-Ring $\varnothing 14 \times 1.78$	1
11	1980210	Piston guide	1	50	1980380	Oil cap	1
12	880830	O-Ring $\varnothing 15.54 \times 2.62$	7	53	180030	Bolt M8x20	(228 in/lbs) 4
13	740290	O-Ring $\varnothing 14 \times 1.78$	1	54	1981140	Spring	3
14	800560	O-Ring $\varnothing 8.73 \times 1.78$	1	55	1981120	Piston	○ □ ▼ ◆ 3
15	1271170	Back-up ring	1	55	1980140	Piston	● ■ ▲ 3
16	1080190	O-Ring $\varnothing 2.9 \times 1.78$	2	56	1980150	Spring retainer	3
17	1271160	Lower piston	1	57	1983100	Rail	1
18	1980200	Valve seat	1	58	1980250	Bearing	1
19	1470210	O-Ring $\varnothing 9 \times 1$	1	59	1980240	Thrust washer	1
20	880581	Plug 1/4" G	2	61	1982710	Hollow shaft	○ ● 1
21	820510	O-Ring $\varnothing 10.82 \times 1.78$	2	61	1982810	Hollow shaft	□ ■ 1
22	620301	Plug 1/8" G	1	61	1982840	Hollow shaft	▼ ▲ 1
23	1980310	Head bolt M10x65	(443 in/lbs) 3	61	1980050	Hollow shaft	◆ 1
24	650530	Lockwasher	3	63	1980340	O-Ring $\varnothing 83.8 \times 2.62$	1
25	1982450	Pump head brass	1	64	1981420	Flange F7	1
25	1982740	Pump head - EZ Start	1	65	1982360	Rear bearing	1
26	1260162	Valve cap	(443 in/lbs) 3	66	1140380	Seal	1
27	960160	O-Ring $\varnothing 17.86 \times 2.62$	3	67	1980430	Spacer	3
28	1269050	Valve assembly	3	77	1981130	Plunger shoe	● ■ ▲ 3
29	1982520	Hose tail	1	78	1981770	Knob plug	1
30	480480	O-Ring $\varnothing 4.48 \times 1.78$	1	79	1982560	Screw TE M6x8 - EZ Start	1
31	1250280	Ball	1	80	1982570	Washer $\varnothing 6.3$ - EZ Start	1
32	1560520	Spring	1	81	1982440	Crub screw M8x8 - EZ Start	1
33	1460430	O-Ring $\varnothing 4 \times 2.5$	1	82	1982240	Ball - EZ Start	1
34	1540170	Check valve	1	83	1981800	Spring - EZ Start	1
35	1080091	Spring	1				
36	394280	O-Ring $\varnothing 12.42 \times 1.78$	1	AR64545	Oil		1
37	1200690	O-Ring $\varnothing 15.6 \times 1.78$	1		OIL CAPACITY - 4.5 OZ		

Legend			Legend		
For ●	For ■	For ▲	For ○	For □	For ▼
SJV2G25	SJV2.5G24	SJV3G25	XJV2G15	XJV2.5G15	XJV3G15
	SJV2.5G25	SJV3G27	XJV2G20	XJV2.5G20	XJV3G20
	SJV2.5G26			XJV2.5G22	XJV3G22
	SJV2.5G27				
			For ◆		
			XJV3.5G22		

SJW & XJW 3400 RPM

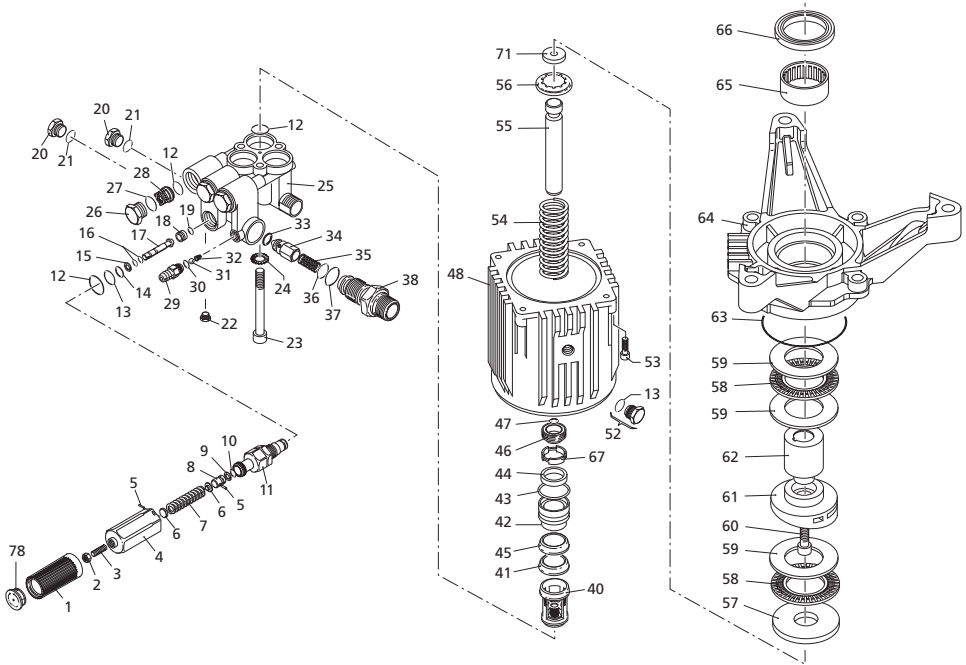

Repair Kits

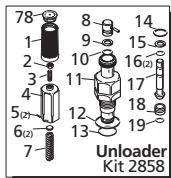
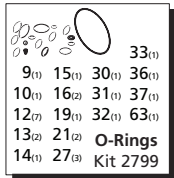
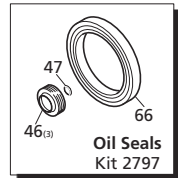
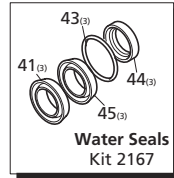
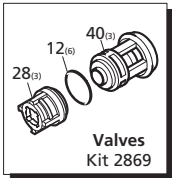

Pos.	Code	Description	Qty.	Pos.	Code	Description	Qty.
1	1981780	Knob	1	38	1270141	Injector adapter	1
2	1980300	Nut	1	40	1989050	Inlet valve	3
3	1540560	Adjusting screw	1	41	1342761	Gasket	3
4	1980390	Handle insert	1	42	1981570	Piston guide	3
5	1080070	Pin	2	43	770260	O-Ring $\phi 23.52 \times 1.78$	3
6	1980220	Plate spring	2	44	1260440	Gasket	3
7	1271070	Spring	1	45	1981580	Ring	3
8	1080041	Upper piston	1	46	1980410	Oil seal	3
9	1080401	Back-up ring	1	47	770090	O-Ring $\phi 5.28 \times 1.78$	1
10	1080250	O-Ring $\phi 7.66 \times 1.78$	1	48	1980460	Pump housing	1
11	1980210	Piston guide	1	52	1980290	Plug $\frac{3}{8}$ "	1
12	880830	O-Ring $\phi 15.54 \times 2.62$	7	53	180030	Bolt M8x20	(228 in/lbs) 4
13	740290	O-Ring $\phi 14 \times 1.78$	2	54	1981140	Spring	3
14	800560	O-Ring $\phi 8.73 \times 1.78$	1	55	1981120	Piston	●■▲ 3
15	1271170	Back-up ring	1	55	1980140	Piston	○□▽ 3
16	1080190	O-Ring $\phi 2.9 \times 1.78$	2	56	1980150	Spring retainer	3
17	1271160	Lower piston	1	57	1983100	Rail	1
18	1980200	Valve seat	1	58	1980250	Bearing	2
19	1470210	O-Ring $\phi 9 \times 1$	1	59	1980240	Thrust washer	3
20	880581	Plug $\frac{1}{4}$ " G	2	60	850370	Bolt M8x16	1
21	820510	O-Ring $\phi 10.82 \times 1.78$	2	61	1980080	Wobble plate	●○ 1
22	620301	Plug $\frac{1}{8}$ " G	1	61	1980070	Wobble plate	■□ 1
23	1980310	Head bolt M10x65	(443 in/lbs) 3	61	1980060	Wobble plate	▲▽ 1
24	650530	Lockwasher	3	62	1980440	Hollow shaft	1
25	1982450	Pump head brass	1	63	1980340	O-Ring $\phi 83.8 \times 2.62$	1
26	1260162	Valve cap	(443 in/lbs) 3	64	1982200	Flange	1
27	960160	O-Ring $\phi 17.86 \times 2.62$	3	65	1980230	Roller bearing	1
28	1269050	Valve assembly	3	66	480671	Seal	1
29	1982520	Hose tail	1	67	1980430	Spacer	3
30	480480	O-Ring $\phi 4.48 \times 1.78$	1	71	1981130	Plunger shoe	●■▲ 1
31	1250280	Ball	1	78	1981770	Knob plug	1
32	1560520	Spring	1				
33	1460430	O-Ring $\phi 4 \times 2.5$	1	AR64545	Oil		1
34	1540170	Check valve	1				
35	1080091	Spring	1				
36	394280	O-Ring $\phi 12.42 \times 1.78$	1				
37	1200690	O-Ring $\phi 15.6 \times 1.78$	1				

Legend

For ● SJW2G25	For ■ SJW2.5G25	For ▲ SJW3G25
For ○ XJW2G20	For □ XJW2.5G20	For ▽ XJW3G20



Plunger Pumps

Torque Specifications in/lbs:(ft/lbs)

	Oil Capacity	Manifold (Head)	Piston Nut	Rear Cover	Side Cover	Valve Cap	Connecting Rods
SJ/XJ	4.5	443/(37)	N/A	228/(19)	N/A	443/(37)	N/A

LIMITED WARRANTY

Annovi Reverberi (A.R.) Cam Shaft Plunger Pumps are warranted for a period of five years and Axial Radial Pumps are warranted for a period of one year to the original purchaser. Electric Pressure Washers are warranted for a period of one year to the original purchaser. This is from the date shipped from factory or U.S. Warehouse. **AR, ArrowLine** and **GF** accessories are warranted for a period of 90 days.

Warranty covers manufacturing defects or workmanship; that may develop under normal use and service in a manner up to the directions and usage recommended by the manufacturer.

Warranty does not apply to misuse or when pump or accessory is altered or used in excess of recommended speeds, pressures, temperatures or handling fluids not suitable for pump or accessory material construction. Warranty does not apply to normal wear (*such as but not limited to: seals/packings, valves, plungers and sealing o-rings*), freight damage, freezing damage or damage caused by parts or accessories not supplied by AR North America, Inc.

Liability of manufacturer for warranty is limited to repair or replacement of parts only at the option of the manufacturer when such products are found to be of original defect or workmanship at the time it was shipped from factory. This warranty is in lieu of all other warranties, expressed or implied, including any warranty of merchantability and of any and all other obligations or liabilities on the part of the manufacturers or equipment.

WARRANTY RETURNS

Items returned for warranty consideration must have a **Returned Merchandise Authorization (RMA)** number. All unauthorized returns will be refused and shipped back to sender. Please fax requests to: 763-398-2009 or e-mail to shop@arnorthamerica.com.