



TML-TMS Series

FEATURES

- The most requested size pump in the pressure cleaning industry.
- Five year limited warranty.
- Forged brass manifold with an exclusive lifetime warranty.
- Large capacity, die-cast, anodized aluminum oil-bath crankcase.
- Over-sized connecting rods for maximum life.
- Heavy-duty ball bearing.
- Solid ceramic plungers with mirror finish and corrosion resistance.
- Stainless steel inlet and discharge valve assemblies.
- Forged valve caps with recessed O-rings.
- Zinc coated manifold bolts for extra corrosion resistance.

SPECIFICATIONS

PUMP MODEL	TML 3045	TML 3545	TML 3053	TMS 3060
Maximum Volume (GPM)	4.5	4.5	5.0	6.0
Max. Discharge Pressure (PSI)	3000	3500	3000	3000
Maximum Pump Speed (RPM)	1450	1450	1450	1725
Maximum Inlet Pressure (PSI)	125			
Maximum Inlet Vacuum	7.9 Hg.			
Bore	18 mm			
Stroke	14 mm	14 mm	15 mm	15 mm
Crankcase Oil Capacity	22 oz.			
Maximum Fluid Temperature	165° F			
Inlet Port Thread	1/2" - 14 BSPP-F			
Discharge Port Thread	3/8" - 19 BSPP-F			
Shaft Diameter	24 mm			
Weight	22.5 lbs			
Dimensions	9.9" x 5.0" x 8.8"			

DIMENSIONAL DRAWING

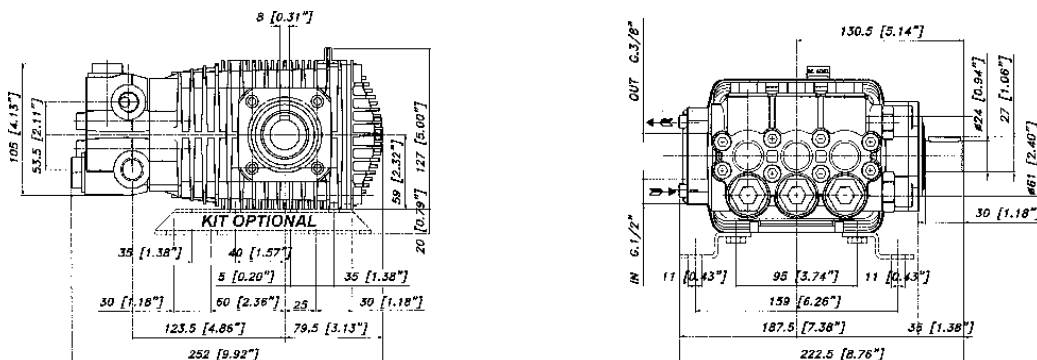

Legacy Model TML-3045-3545-3053; TMS-3060

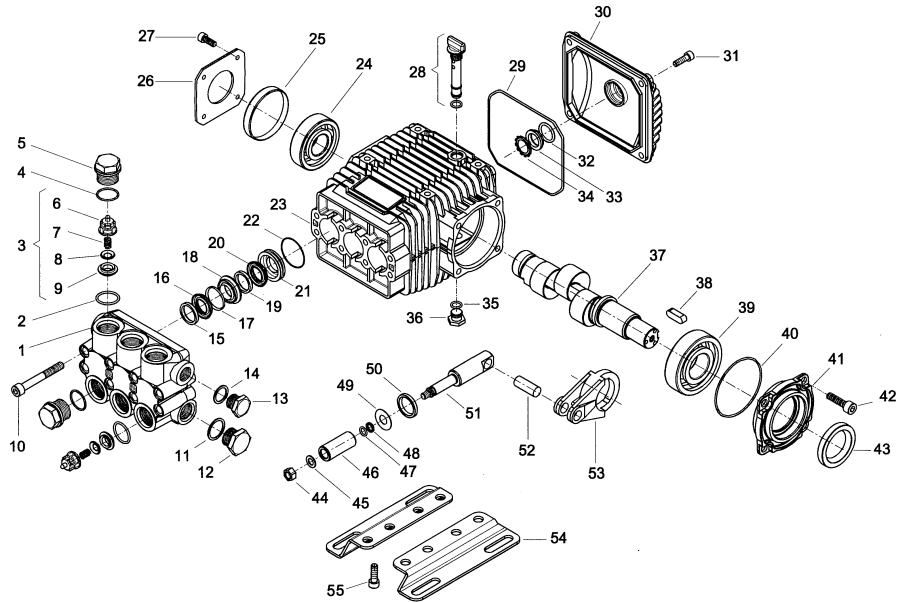

POS NO.	PART NO.	DESCRIPTION	KIT	NO. PCS.
1	15-070071282	Pump Head		1
2	15-803182002	O-Ring Dia. 2.62 x 17.13	123	6
3	15-069846973	Check Valve	123	6
4	15-803182002	O-Ring Dia. 2.62 x 17.13		6
5	15-070040532	Ex. Deep Sealing Valve Cap M27x1.5		6
6	15-060105322	Valve Cage	123	6
7	15-940054512	Valve Spring	123	6
8	15-060104512	Poppet	123	6
9	15-060110512	Valve Seat	123	6
10	15-862985002	Screw TCEI M8x70 UNI 5931		8
11	15-824140002	Gasket for Coupling 21.2 x 26 x 1		1
12	15-852629002	Plug G 1/2"		1
13	15-852579002	Plug G 3/8		1
14	15-824109002	Copper Gasket Dia. 17x22x1		1
15	15-050019322	Seal Packer DN 18/28	71, 76	3
16	15-802061002	V-Packing Dia. 18 x 28 x 5.5	71, 76	3
17	15-050221322	External Check Ring (EX 050088322)	71, 76	3
18	15-070013532	Front Gland D.18	71	3
19	15-050019322	Seal Packer DN 18/28	71, 76	3
20	15-802061002	V-Packing Dia. 18 x 28 x 5.5	71, 76	3
21	15-070014532	Rear Gland D.18	71	3
22	15-803080002	O-Ring	71, 76	3
23	15-070001092	Crankcase		1
24	15-812725002	Bearing Riv 6B 25		1
25	15-802102002	Cover 62x07 RCA		1
26	15-050045612	Crankcase Cover		1
27	15-862108002	Screw M6x16 UNI 5931		4
28	15-049832973	Filler Plug		1
29	15-803210682	O-Ring D.2.62 x 120.32		1
30	15-040117092	Rear Cover		1
31	15-862168002	Galvanized Screw M6x22 UNI 5931		4

POS NO.	PART NO.	DESCRIPTION	KIT	NO. PCS.
32	15-803189002	O-Ring Dia.2.62x18.72		1
33	15-040120322	Oil Sight Glass		1
34	15-801184002	Ring		1
35	15-803057002	O-Ring 2037 - 39.34 x 2.62		1
36	15-852543502	Cap G. 1/4 x 9 (EX852542002)		1
37/1	15-070037262	Crankshaft D.24 E=8 (L3045, L3545)		1
37/2	15-070038262	Crankshaft D.24 E=9 (L3053, S3060)		1
38	15-806534002	Tab 8x7x35		1
39	15-812776002	Bearing		1
40	15-803080702	O-Ring D.1.78 x 69.57		1
41	15-070003092	Support		1
42	15-862547002	Screw M8x18		4
43	15-802119002	Oil Seal 30x52x7		1
44	15-814561002	Stainless Steel Nut M8 UNI 5589		3
45	15-843642902	Washer Dia. 8.1x14x1		3
46	15-070008182	Ceramic Piston DN 18		3
47	15-803055502	Viton O-Ring Dia. 1.78x7.76		3
48	15-803912002	Backup Ring 2031 Dia. 10.8		3
49	15-843826002	Washer D.11.3x25x0.5 Copper		3
50	15-802063502	Axial Ring	65	3
51	15-070010512	Guide X D.18		3
52	15-852006282	Piston Ring		3
53/1	15-070006092	Conrod, Alum (3000 psi)		3
53/2	15-070005112	Conrod, Bronze (3500 psi)		3
54	15-040247612	Mounting Rail (Optional)		2
55	15-862495002	Screw M8x16 (Optional)		4
56	15-079802973	Mounting Rail Kit (Optional)		1

	KIT 123 CHECK VALVE/O-RING	KIT 65 PLUNGER OIL SEAL	KIT 71 PACKING/ BRASS ASSY	KIT 76 PACKING ONLY
KIT BREAKDOWN				
PART #	15-069867973	15-049837973	15-079805973	15-079807973
TOTAL PCS.	12	3	24	18