



TMG Series

FEATURES

- The most requested size pump in the pressure cleaning industry.
- Five year limited warranty.
- Forged brass manifold with an exclusive lifetime warranty.
- Large capacity, die-cast, anodized aluminum oil-bath crankcase.
- Over-sized connecting rods for maximum life.
- Heavy-duty ball bearing.
- Solid ceramic plungers with mirror finish and corrosion resistance.
- Stainless steel inlet and discharge valve assemblies.
- Forged valve caps with recessed O-rings.
- Zinc coated manifold bolts for extra corrosion resistance.

SPECIFICATIONS

PUMP MODEL	TMG 3535	TMG 4040
Maximum Volume (GPM)	3.5	4
Max. Discharge Pressure (PSI)	3500	4000
Maximum Pump Speed	3450 RPM	
Maximum Inlet Pressure	125 PSI	
Maximum Inlet Vacuum	Flooded	
Bore	15 mm	
Stroke		
Crankcase Oil Capacity	15.5 Oz.	
Maximum Fluid Temperature	165° F	
Inlet Port Thread	1/2" - 14 BSSP-F	
Discharge Port Thread	3/8" - 19 BSSP-F	
Shaft Diameter	1" Hollow	
Weight	19.8 Lbs.	
Dimensions	8.9" x 9.6" x 8.5"	

DIMENSIONAL DRAWING

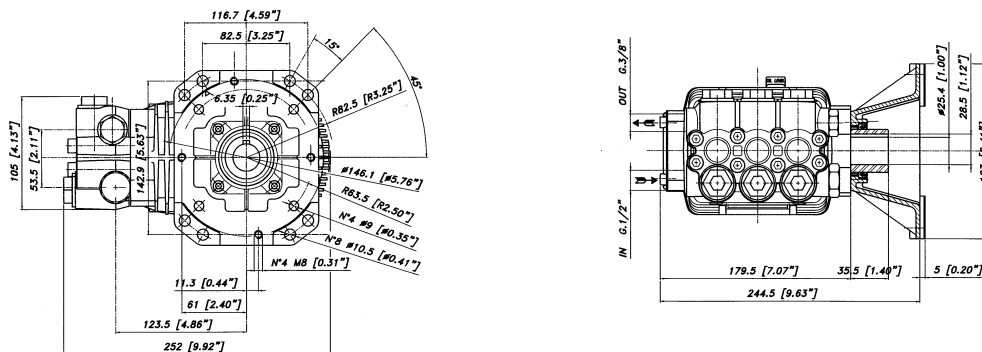

Legacy Model TMG 3535 - 4040

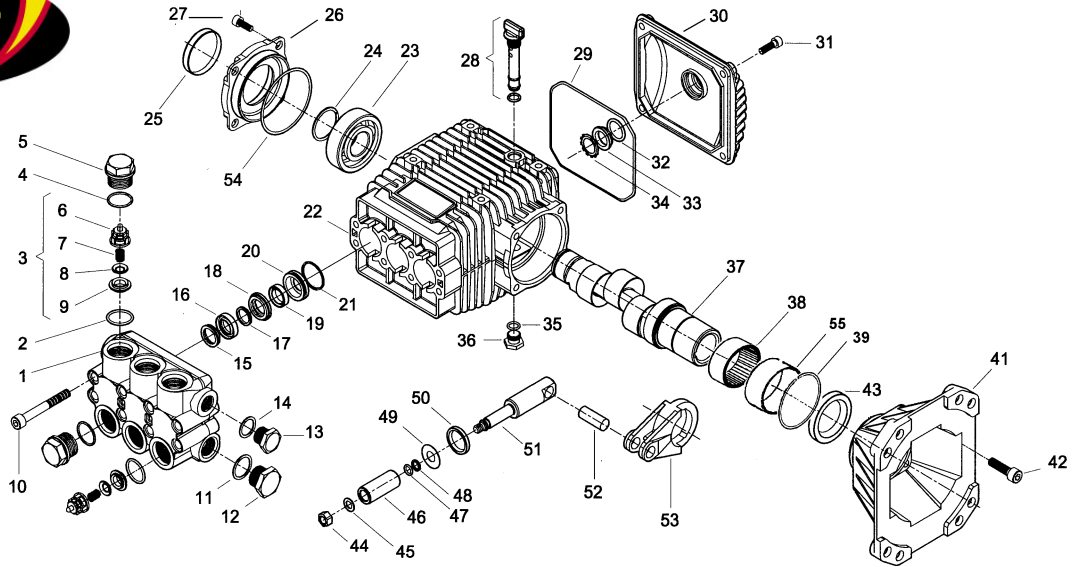

POS NO.	PART NO.	DESCRIPTION	KIT	NO. PCS.
1	15-070070282	Pump Head		1
2	15-803182002	O-Ring Dia. 2.62x17.13	123	6
3	15-079819973	Check Valves	123	6
4	15-803182002	O-Ring Dia. 2.62x17.13		6
5	15-070040532	EX. Deep Sealing Valve Cap M27x1.5		6
6	15-060105322	Valve Cage	123	6
7	15-070048512	Valve Spring	123	6
8	15-060104512	Poppet	123	6
9	15-040023512	Valves Assembly Seat	123	6
10	15-862985002	Screw TCEI M8x70 UNI 5931		8
11	15-824140002	Gasket for Coupling 21.2x26x1		1
12	15-852629002	Plug G 1/2"		1
13	15-852579002	Plug G 3/8		1
14	15-824109002	Copper Gasket Dia. 17x22x1		1
15	15-040270322	Seal Packer	69, 74	3
16	15-802020002	Packing D.15	69, 74	3
17	15-040269322	Anti-Extrusion Ring	69, 74	3
18	15-040268532	Front Gland	69	3
19	15-802034002	U Pressure Seal Dia. 15x22x5.5	69, 74	3
20	15-070016532	Rear Gland	69	3
21	15-803080002	O-Ring	69, 74	3
22	15-070001092	Crankcase		1
23	15-812776002	Bearing		1
24	15-801241002	Circlip		1
25	15-802099602	Cap RCA 52-7		1
26	15-070003092	Support		1
27	15-862547002	Screw M8x18		4
28	15-049832973	Filler Plug		1
29	15-803210682	O-Ring D.2 62x120.32		1

POS NO.	PART NO.	DESCRIPTION	KIT	NO. PCS.
30	15-040117092	Rear Cover		1
31	15-862168002	Galvanized Screw M6x22 UNI 5931		4
32	15-803189002	O-Ring Dia. 2.62x18.72		1
33	15-040120322	Oil Sight Glass		1
34	15-801184002	Ring		1
35	15-803057002	O-Ring 2037 - 39.34 x 2.62		1
36	15-852543502	Cap G 1/4x9 (EX 852542002)		1
37/1	15-070057262	Hollow Shaft 1" E4.3 (3535)		1
37/2	15-070058262	Hollow Shaft 1" E9 (4040)		1
38	15-812916002	Needle Bearing		1
39	15-801400002	Ring D.62 for Hole		1
41	15-070045092	Motor FlangeVSAE 1"		1
42	15-862216002	Screw M6x25		4
43	15-802191002	Shaft Oil Seal		1
44	15-814561002	Stainless Steel Nut M8 UNI 5589		1
45	15-843642902	Washer Dia. 8.1x14x1		4
46	15-070007182	Ceramic Piston DN15		1
47	15-803049002	O-Ring Dia. 1.78x5.28		3
48	15-803908502	Seal		3
49	15-843726002	Washer Dia. 9.1x24x1		3
50	15-802063502	Axial Ring	65	3
51	15-070009512	Plunger Rod		3
52	15-852006282	Piston Pin		3
53	15-070005112	Bronze Conrod		3
54	15-803080702	O-Ring D.1.78x69.57		3
55	15-070046412	Bushing for Bearing		3

	KIT 123 CHECK VALVE/O-RING	KIT 65 PLUNGER OIL SEAL	KIT 69 F&G PACKING ASSY	KIT 74 F&G PACKING ONLY
KIT BREAKDOWN				
PART #	15-069867973	15-049837973	15-079804973	15-079806973
TOTAL PCS.	12	3	21	15