



GG-1 Series

FEATURES

- Designed and engineered for pressure washers.
- Five year limited warranty.
- Forged brass manifold with an exclusive lifetime warranty.
- Die-cast, anodized aluminum oil-bath crankcase.
- Aluminum two piece connecting rods with lubrication channel and forged crankshaft for maximum life.
- Heavy-duty crankshaft bearing.
- Solid ceramic plungers with mirror finish and corrosion resistance.
- Parker® "V" seals for premium performance.
- Stainless steel inlet and discharge valve assemblies.
- Forged valve caps with recessed O-rings to withstand high pressures.
- Dacromet® coated manifold bolts for superior corrosion resistance.
- Precision oil dipstick for proper ventilation of crankcase.
- Flanged for direct couple to gasoline engines with 1" shaft (SAE J609)



SPECIFICATIONS

PUMP MODEL	GG3035G1	GG3535G1	GG4030G1
Maximum Volume (GPM)	3	3.5	4
Max. Discharge Pressure (PSI)	3500	3500	3000
Maximum Pump Speed	3400	3400	3400
Maximum Inlet Pressure	125 psi		
Maximum Inlet Vacuum	Flooded		
Bore	15 mm	15 mm	15 mm
Stroke	7.8 mm	9.2 mm	10.0 mm
Crankcase Oil Capacity	14 oz.		
Maximum Fluid Temperature	165°F		
Inlet Port Thread	1/2-14 BSPP-F		
Discharge Port Thread	3/8-19 BSPP-F		
Shaft Diameter	1" Hollow		
Weight	18 lbs.		
Dimensions (LxWxH)	8.5 x 9.5 x 6.5 in.		



GG-1 Series Pump

5-1955 GG3035G1
 5-1956 GG3535G1
 5-1958 GG4030G1

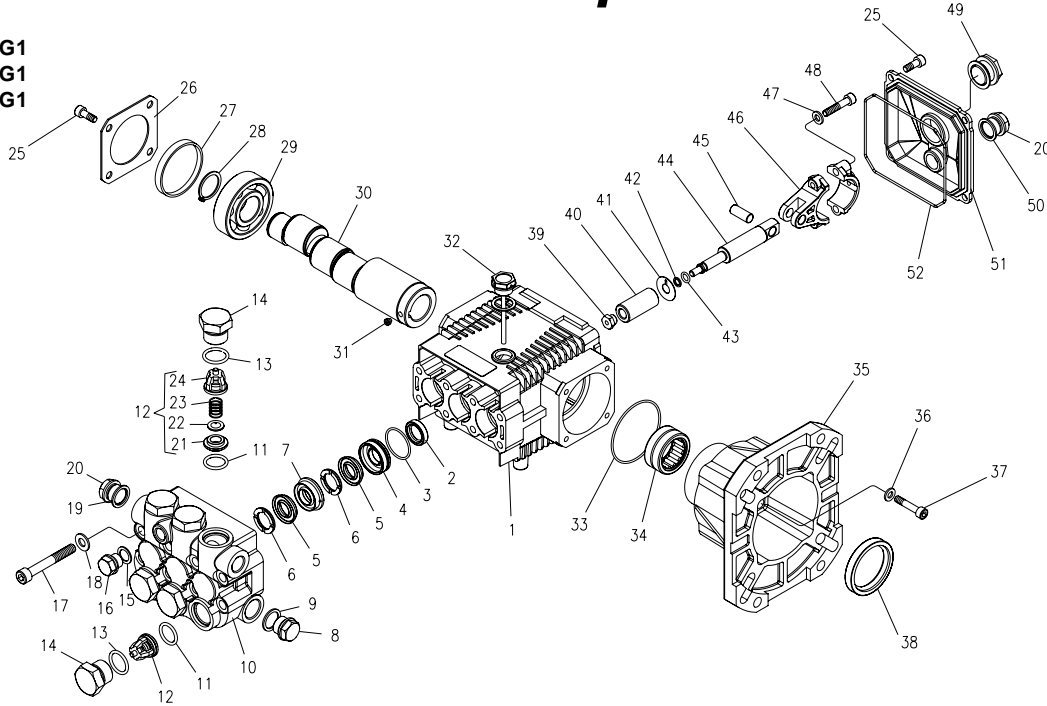

TORQUE SPECS	
Item #	Ft.-lbs
14	65
17	22
25	8
37	8
39	9
48	13

PARTS LIST

ITEM	PART NO.	DESCRIPTION	QTY	ITEM	PART NO.	DESCRIPTION	QTY	ITEM	PART NO.	DESCRIPTION	QTY
1	70-020292	Crankcase	1	19	70-060306	Copper Washer 3/8"	1	38	70-000109	Crankshaft Seal	1
2*	See Kit Below	Plunger Oil Seal	3	20	70-160117	Brass Plug 3/8"	2	39*	70-030211	Plunger Nut	3
3*	70-060107	O-Ring Ø1.78 x 31.47	3	25	70-180112	Hexagonal Screw	9	40*	See Kit Below	Plunger, 15mm	3
4*	70-120120	Pressure Ring, 15mm	3	26	70-020318	Bearing Cover	1	41*	70-140027	Copper Spacer	3
5*	See Kit Below	"V" Seal, 15mm	6	27	70-020502	Seal Bearing	1	42*	70-060130	O-Ring Ø1.78x5.28	3
6*	70-030027	Support Ring 15mm	6	28	70-150003	Snap Ring	1	43*	70-000913	Teflon Ring	3
7	70-030049	Intermediate Ring 15mm	3	29	70-021300	Ball Bearing	1	44	70-000320	Plunger Rod	3
8	70-160120	Brass Plug, 1/2"	1	30	70-000495	Crankshaft (3035G1)	1	45	70-150204	Connecting Rod Pin	3
9	70-060307	Copper Washer 1/2"	1		70-000496	Crankshaft (3535G1)	1	46	70-010008	Connecting Rod	3
10	70-160228	Manifold Housing	1		70-000497	Crankshaft (4030G1)	1	47	70-140102	Spring Washer	6
11*	70-060155	O-Ring Ø1.78 x 15.54	6	31	70-180302	Set Screw	1	48	70-180132	Connecting Rod Screw	6
12*	See Kit Below	Valve Assembly	6	32	70-160012	Oil Dip Stick	1	49	70-070005	Sight Glass, G3/8	1
13*	70-060122	O-Ring Ø2.62 x 18.77	6	33	70-060183	O-Ring 3.53 x 55.56	1	50	70-060302	Gasket, G3/8	1
14	70-160147	Valve Plug	6	34	70-020010	Needle Roller Bearing	1	51	70-020352	Crankcase Cover	1
15	70-060308	Washer, Copper	1	35	70-050055	Engine Flange	1	52	70-060104	O-Ring 2.62 x 107.62	1
16	70-160121	Brass Plug G1/4	1	36	70-140002	Spring Washer	4				
17	70-180118	Manifold Stud Bolt	8	37	70-180132	Flange Screw	4				
18	70-140001	Washer	8								

* Part available in kit (See below)

REPAIR KITS

REPAIR KIT NUMBER	70-261408	70-261409	70-261404	70-260028	70-260826
KIT DESCRIPTION	Plunger Seal 15mm	Complete Seal Packing 15mm	Plunger 15mm	Complete Valve	Plunger Oil Seals
ITEM NUMBERS INCLUDED	3, 5, 6	2, 3, 4, 5, 6, 7	39, 40, 41, 42, 43	11, 12, 13	2
NUMBER OF CYLINDERS KIT WILL SERVICE	3	1	1	6	3