



GD Series

FEATURES

- Designed and engineered exclusively for pressure washers.
- Five year limited warranty.
- Forged brass manifold with an exclusive lifetime warranty.
- Die-cast, anodized aluminum oil-bath crankcase.
- Aluminum two piece connecting rods with lubrication channels for maximum life.
- Heavy-duty crankshaft bearings.
- Solid ceramic plungers with mirror finish and corrosion resistance.
- Stainless steel inlet and discharge valve assemblies.
- Forged valve caps with recessed O-rings.
- Dacromet® coated manifold bolts for extra corrosion resistance.
- Precision oil dipstick for proper ventilation of crankcase.
- Parker® low and high pressure seals.



SPECIFICATIONS

PUMP MODEL	GD-3025	GD-3030	GD-3030H	GD-4020
Maximum Volume (GPM)	3	3	3	4.0
Max. Discharge Pressure (PSI)	2500	3000	3000	2000
Maximum Pump Speed	1180	1650	1650	1550
Maximum Inlet Pressure	125 PSI			
Maximum Inlet Vacuum	3 ft. water (2.6 in. HG)			
Bore	18 mm	15 mm	15 mm	18 mm
Stroke	13.6 mm			
Crankcase Oil Capacity	14 oz.			
Maximum Fluid Temperature	165° F		185° F	165° F
Inlet Port Thread	1/2-14 BSPP-F			
Discharge Port Thread	3/8-19 BSPP-F			
Shaft Diameter	24 mm			
Weight	16 lbs			
Dimensions (LxWxH)	8.5 x 8.4 x 5.0			



GD Series Pump

5-1907 GD 3025
 5-1909 GD 3030
 5-1906 GD 3030H
 5-1908 GD 4020

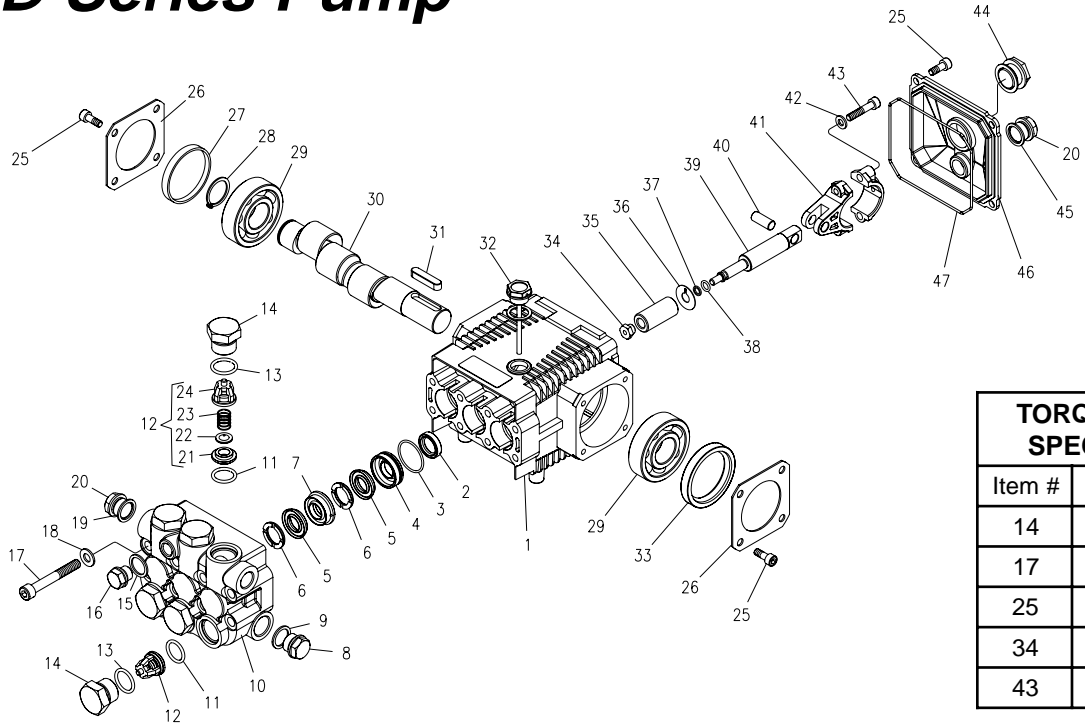

TORQUE SPECS	
Item #	Ft.-lbs
14	65
17	22
25	8
34	9
43	13

PARTS LIST

ITEM	PART NO.	DESCRIPTION	QTY	ITEM	PART NO.	DESCRIPTION	QTY	ITEM	PART NO.	DESCRIPTION	QTY
1	70-020292	Crankcase	1	11*	70-060155	O-Ring Ø1.78 x 15.54	6	33	70-000110	Crankshaft Seal	1
2*	SeeKitsBelow	Plunger Oil Seal	3	12*	SeeKitsBelow	Valve Assembly	6	34*	70-030211	Plunger Nut	3
3*	70-060181	O-Ring Ø1.78 x 28.30	3	13*	70-060122	O-Ring Ø2.62 x 18.77	6	35*	70-120023	Plunger, 15mm (3030)	3
4*	70-120131	Pressure Ring 15mm (3030)	3	14	70-160147	Valve Plug	6		70-120022	Plunger, 18mm (4020, 3025)	3
	70-120132	Pressure Ring 18mm (4020, 3025)	3	15	70-060308	Copper Washer 1/4	1	36*	70-140027	Copper Spacer	3
5*	SeeKitsBelow	"V" Seal, 15mm (3030)	6	16	70-160121	Brass Plug G1/4	1	37*	70-060130	O-Ring Ø1.78 x 5.28	3
	SeeKitsBelow	"V" Seal, 18mm (4020, 3025)	6	17	70-180118	Manifold Stud Bolt	8	38*	70-000913	Teflon Ring	3
6*	70-030048	Support Ring 15mm (3030)	6	18	70-140001	Washer	8	39*	70-000320	Plunger Rod	3
	70-030050	Support Ring 18mm (4020, 3025)	6	19	70-060306	Copper Washer 3/8	1	40	70-150204	Connecting Rod Pin	3
7*	70-030049	Intermed. Ring 15mm (3030)	3	20	70-160117	Brass Plug 3/8	2	41	70-010008	Connecting Rod	3
	70-030051	Intermed. Ring 18mm (4020, 3025)	3	25	70-180112	Screw	12	42	70-140102	Spring Washer	6
8	70-160120	Brass Plug 1/2"	1	26	70-020318	Bearing Cover	2	43	70-180132	Connecting Rod Screw	6
9	70-060307	Copper Washer 1/2"	1	27	70-020502	Bearing Seal	1	44	70-070005	Sight Glass	1
10	70-160228	Manifold Housing	1	28	70-150003	Snap Ring	1	45	70-060302	Gasket	1
				29	70-021300	Ball Bearing	2	46	70-020352	Crankcase Cover	1
				30	70-000605	Crankshaft	1	47	70-060104	O-Ring Ø2.62 x 107.62	1
				31	70-020604	Crankshaft Key	1				
				32	70-160012	Oil Dipstick	1				

* Available in kit (See below)

REPAIR KITS

REPAIR KIT NUMBER	70-261408	70-261410	70-261409	70-261411	70-261404	70-261405	70-260028	70-260826
KIT DESCRIPTION	*Plunger Seal 15mm GD-3030	Plunger Seal 18mm GD-3025 GD-4020	**Complete Seal Packing GD-3030	Complete Seal Packing GD-3025 GD-4020	Plunger 15mm GD-3030	Plunger 18mm GD-3025 GD-4020	Complete Valve	Plunger Oil Seals
ITEM NUMBERS INCLUDED	3, 5, 6	3, 5, 6	2, 3, 4, 5, 6, 7	2, 3, 4, 5, 6, 7	34, 35, 36, 37, 38	34, 35, 36, 37, 38	11, 12, 13	2
NUMBER OF CYLINDERS KIT WILL SERVICE	3	3	1	1	1	1	6	3