



GS Series

FEATURES

- Designed and engineered for pressure washers.
- Five year limited warranty.
- Forged brass manifold with an exclusive lifetime warranty.
- Large capacity, die-cast, anodized aluminum oil-bath crankcase.
- Over-sized connecting rods and crankshaft for maximum life.
- Heavy-duty dual raceway crankcase bearing.
- High load capacity flange needle bearing.
- Solid ceramic plungers with mirror finish and corrosion resistance.
- Parker "V" seals for premium performance.
- Stainless steel inlet and discharge valve assemblies.
- Forged valve caps with recessed O-rings to withstand high pressures.
- Dacromet® coated manifold bolts for superior corrosion resistance.



SPECIFICATIONS

PUMP MODEL	HS3040G	HS3540G	HS4040G	HS5030G
Maximum Volume (GPM)	3	3.5	4	5
Max. Discharge Pressure (PSI)	4000	4000	4000	3000
Maximum Pump Speed	3400	3400	3400	3400
Maximum Inlet Pressure	125 psi			
Maximum Inlet Vacuum	Flooded			
Bore	15 mm	15 mm	15 mm	15 mm
Stroke	7.7 mm	9 mm	10.3 mm	12 mm
Crankcase Oil Capacity	23.3 oz.			
Maximum Fluid Temperature	165°F			
Inlet Port Thread	1/2-14 BSPP-F			
Discharge Port Thread	3/8-19 BSPP-F			
Shaft Diameter	1" Hollow			
Weight	24.5 lbs.			
Dimensions	11 x 10.2 x 5.7 in.			



GS Series Pump

5-1960 GS3040G
 5-1961 GS3540G
 5-1962 GS4040G
 5-1963 GS5030G

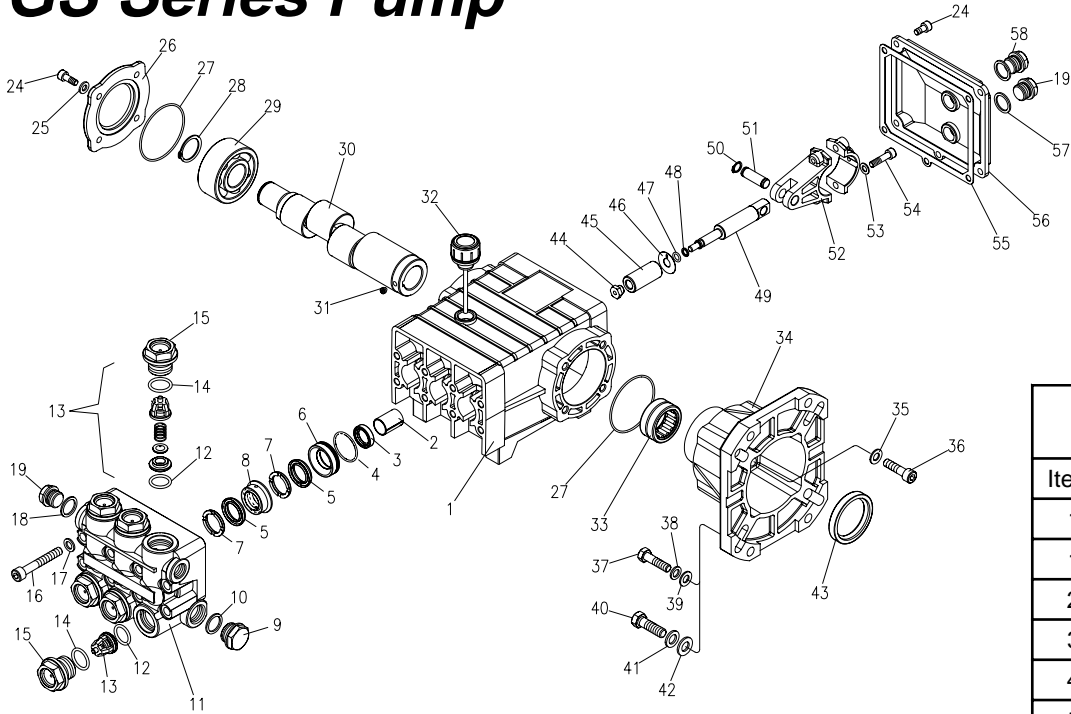

TORQUE SPECS	
Item #	Ft.-lbs
15	75
16	30
24	8
36	8
44	9
54	13

PARTS LIST

ITEM	PART NO.	DESCRIPTION	QTY	ITEM	PART NO.	DESCRIPTION	QTY	ITEM	PART NO.	DESCRIPTION	QTY
1	70-020225	Crankcase	1	24	70-180112	Hexagonal Screw	9	40	70-180221	Engine Screw 3/8"	4
2	70-060201	Plunger Guide	3	25	70-140002	Washer	4	41	70-140052	Washer	4
3*	See Kit Below	Plunger Oil Seal	3	26	70-050056	Closed Bearing Housing	1	42	70-140053	Spring Washer	4
4*	70-060107	O-Ring Ø1.78 x 31.47	3	27	70-060163	O-Ring Ø 1.78 x 60.05	2	43	70-000109	Crankshaft Seal	1
5*	See Kit Below	"V" Seal , 15mm	6	28	70-150003	Snap Ring	1	44*	70-030211	Plunger Nut	3
6*	70-120120	Pressure Ring, 15mm	3	29	70-021310	Double Row Ball Bearing	1	45*	See Kit Below	Plunger, 15mm	3
7*	70-030027	Support Ring 15mm	6	30	70-000491	Crankshaft (LS3040G)	1	46*	70-140027	Copper Spacer	3
8*	70-030020	Intermed. Ring 15mm	3		70-000492	Crankshaft (LS3540G)	1	47*	70-060130	O-Ring Ø1.78x5.28	3
9	70-160120	Brass Plug, 1/2"	1		70-000493	Crankshaft (LS4040G)	1	48*	70-000913	Teflon Ring	3
10	70-060307	Copper Washer 1/2"	1		70-000494	Crankshaft (LS5030G)	1	49	70-000302	Plunger Rod	3
11	70-160216	Manifold Housing	1	31	70-180302	Set Screw	1	50	70-150001	Snap Ring	6
12*	70-060119	O-Ring Ø2.62 x 17.13	6	32	70-160006	Oil Dip Stick	1	51	70-150201	Connecting Rod Pin	3
13*	See Kit Below	Valve Assembly	6	33	70-020010	Needle Roller Bearing	1	52	70-010001	Connecting Rod	3
14*	70-060165	O-Ring Ø2.62 x 20.29	6	34	70-050055	Engine Flange	1	53	70-140102	Spring Washer	6
15	70-160130	Valve Plug	6	35	70-140304	Spring Washer	4	54	70-180105	Connecting Rod Screw	6
16	70-180103	Manifold Stud Bolt	8	36	70-180128	Flange Screw	4	55	70-060009	Cover Gasket	1
17	70-140001	Washer	8	37	70-180220	Engine Screw, 5/16"	4	56	70-020350	Crankcase Cover	1
18	70-060306	Copper Washer 3/8"	1	38	70-140051	Washer	4	57	70-060302	Gasket, G3/8	1
19	70-160117	Brass Plug 3/8"	2	39	70-140103	Spring Washer	4	58	70-070001	Sight Glass, G3/8	1

* Part available in kit (See below)

REPAIR KITS

REPAIR KIT NUMBER	70-260824	70-260825	70-260823	70-260007	70-260027
KIT DESCRIPTION	Plunger Seal 15mm	Complete Seal Packing 15mm	Plunger 15mm	Complete Valve	Plunger Oil Seals
ITEM NUMBERS INCLUDED	4, 5, 7	3, 4, 5, 6, 7, 8	44, 45, 46, 47, 48	12, 13, 14	3
NUMBER OF CYLINDERS KIT WILL SERVICE	3	1	1	6	3