

FEATURES

G3 Evolution

- Designed and engineered for pressure washers.
- Seven year limited warranty.
- Forged brass manifold with an exclusive lifetime warranty.
- Die-cast, anodized aluminum oil-bath crankcase.
- Aluminum two piece connecting rods with lubrication channel and forged crankshaft for maximum life.
- Heavy-duty crankshaft bearing.
- Solid ceramic plungers with mirror finish and corrosion resistance.
- Parker® U-Seals for premium performance.
- Stainless steel inlet and discharge valve assemblies.
- Forged valve caps with recessed O-rings to withstand high pressures.
- Dacromet® coated manifold bolts for superior corrosion resistance.
- Precision oil dipstick for proper ventilation of crankcase.
- Flanged for direct couple to gasoline engine with 3/4" shaft (SAE J609)



SPECIFICATIONS

PUMP MODEL	LG2530G.1	LG3030G.1
Maximum Volume (GPM)	2.5	3.0
Max. Discharge Pressure (PSI)	3000	3000
Maximum Pump Speed	3400	3400
Maximum Inlet Pressure	125 psi	
Maximum Inlet Vacuum	Flooded	
Bore	15 mm	15 mm
Stroke	3.2 mm	3.8 mm
Crankcase Oil Capacity	14 oz.	
Maximum Fluid Temperature	185°F	
Inlet Port Thread	1/2-14 BSPP-F	
Discharge Port Thread	3/8-19 BSPP-F	
Shaft Diameter	3/4" Hollow	
Weight	16.5 lbs.	
Dimensions (LxWxH)	8.5 x 8.0 x 5.0 in.	

LANDA® LG.1 Series Pump

8.904-893.0 LG2530G.1
8.904-895.0 LG3030G.1

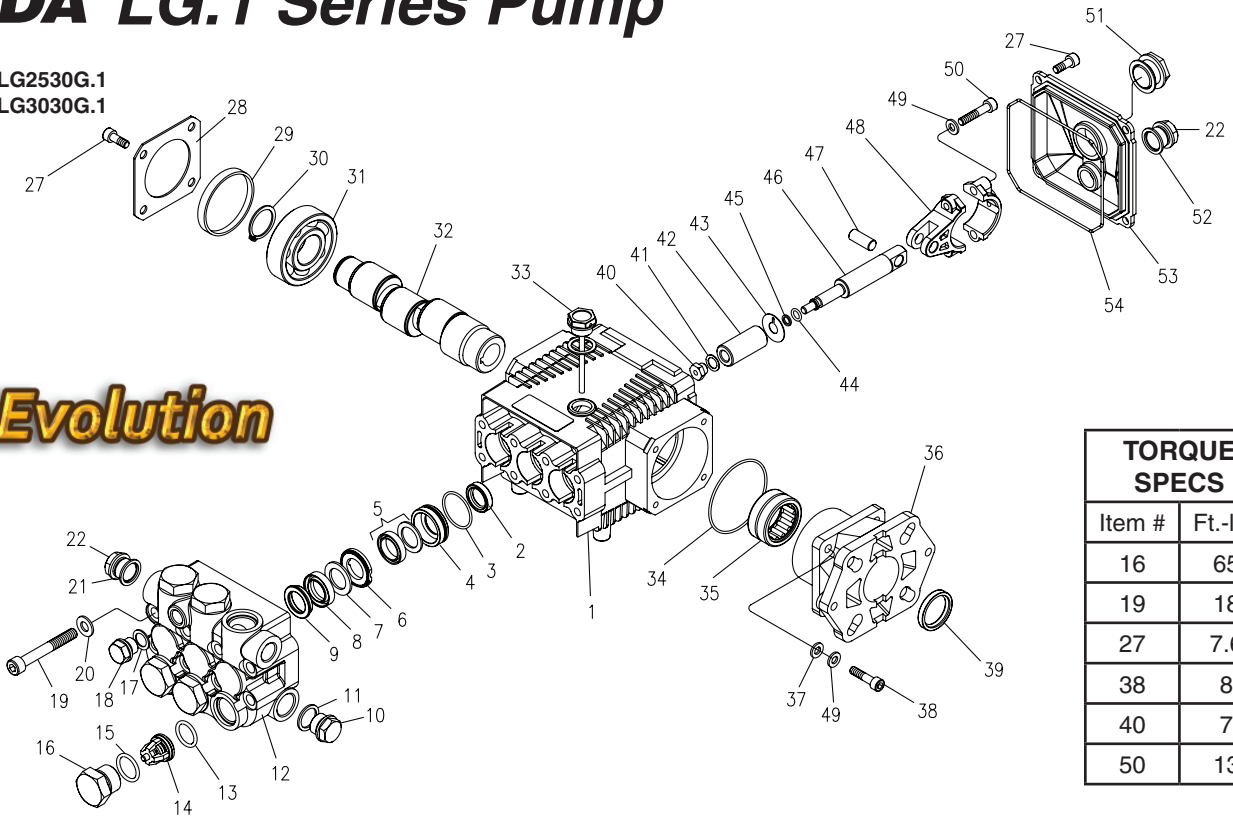

TORQUE SPECS	
Item #	Ft.-lbs
16	65
19	18
27	7.6
38	8
40	7
50	13

PARTS LIST

ITEM	PART NO.	DESCRIPTION	QTY	ITEM	PART NO.	DESCRIPTION	QTY	ITEM	PART NO.	DESCRIPTION	QTY
1	9.803-938.0	Crankcase	1	19	9.803-952.0	Manifold Stud Bolt	8	39	9.804-585.0	Crankshaft Seal	1
2*	See Kit Below	Plunger Oil Seal	3	20	9.802-884.0	Washer	8	40*	See Kit Below	Plunger Nut	3
3*	See Kit Below	O-Ring Ø1.78 x 28.30	3	21	9.803-198.0	Copper Washer 3/8"	1	41*	See Kit Below	Copper Spacer	3
4*	See Kit Below	Pressure Ring, 15mm	3	22	9.802-925.0	Brass Plug 3/8"	2	42*	See Kit Below	Plunger, 15mm	3
5*	See Kit Below	U-Seal, 15mm	3	27	9.802-939.0	Hexagonal Screw	9	43*	See Kit Below	Copper Spacer	3
6*	See Kit Below	Intermediate Ring 15mm	3	28	9.803-953.0	Bearing Cover	1	44*	See Kit Below	O-Ring Ø1.78x5.28	3
7*	See Kit Below	Backup Ring 15mm	3	29	9.803-954.0	Seal Bearing	1	45*	See Kit Below	Teflon Ring	3
8*	See Kit Below	U-Seal, 15mm	3	30	9.802-914.0	Snap Ring	1	46	9.803-964.0	Plunger Rod	3
9*	See Kit Below	Support Ring, 15mm	3	31	9.803-955.0	Ball Bearing	1	47	9.803-965.0	Connecting Rod Pin	3
10	9.802-926.0	Brass Plug, 1/2"	1	32	8.717-069.0	Crankshaft (2530G)	1	45	9.803-966.0	Connecting Rod	3
11	9.803-199.0	Copper Washer 1/2"	1		8.717-070.0	Crankshaft (3030G)	1	49	9.803-218.0	Spring Washer	6
12	9.803-946.0	Manifold Housing	1	33	9.803-957.0	Oil Dip Stick	1	50	8.933-020.0	Connecting Rod Screw	6
13*	9.803-947.0	O-Ring Ø1.78 x 15.54	6	34	9.804-581.0	O-Ring 3.53 x 55.56	1	54	9.803-969.0	O-Ring 2.62 x 107.62	1
14*	See Kit Below	Valve Assembly	6	35	9.804-582.0	Needle Roller Bearing	1	53	9.803-968.0	Crankcase Cover	1
15*	9.803-948.0	O-Ring Ø2.62 x 18.77	6	36	8.717-212.0	Engine Flange	1	52	9.803-197.0	Gasket, G3/4	1
16	9.803-949.0	Valve Plug	6	37	9.803-210.0	Spring Washer	4	51	9.803-202.0	Sightglass G3/4	1
17	9.803-950.0	Washer, Copper	1	38	9.804-584.0	Flange Screw	4				
18	9.803-951.0	Brass Plug G1/4	1								

* Part available in kit (See below)

REPAIR KITS

REPAIR KIT NUMBER	8.725-354.0	8.725-355.0	9.803-934.0	9.803-936.0	9.803-937.0
KIT DESCRIPTION	Plunger Seal 15mm	Complete Seal Packing 15mm	Plunger 15mm	Complete Valve	Plunger Oil Seals
ITEM NUMBERS INCLUDED	3, 5, 7, 8, 9	3, 4, 5, 6, 7, 8, 9	40, 41, 42, 43, 44, 45	13, 14, 15	2
NUMBER OF CYLINDERS KIT WILL SERVICE	3	1	1	6	3