SUNTEC PERFORMANCE-PROVEN FUEL UNITS AND VALVES

...for residential and commercial applications

SUNTEC, THE INDUSTRY LEADERS ●
BUILT ON OUR COMMITMENT

Knowing the industry's need and responding to them with the right products and services is one of the responsibilities of leadership. Over the years, Suntec has been committed to being involved, asking questions, listening and providing answers. Today, as the industry leaders, our involvement is as strong as ever. We still work hard to earn your trust in us as the experts in our field. You shouldn't have to settle for less.

MODEL A-7000 ● SINGLE-STAGE FUEL UNITS

- Single-pipe installations to 6" hg. vacuum
- Two-pipe installations to 12" hg. vacuum
- Lift or gravity feed applications with 10 psi maximum inlet/return pressure
- Choice of 1725, 2850, 3450 rpm
- Suitable for no. 2, no. 1 fuel oil, or kerosene
- Mounting in any position
- Factory-set at 100 psi
- Adjustable range 100-150 psi at 3450 rpm, 100-135 psi at 1725 rpm. Models available to 200 and 300 psi.



SPECIFICATIONS* /ORDERING INFORMATION

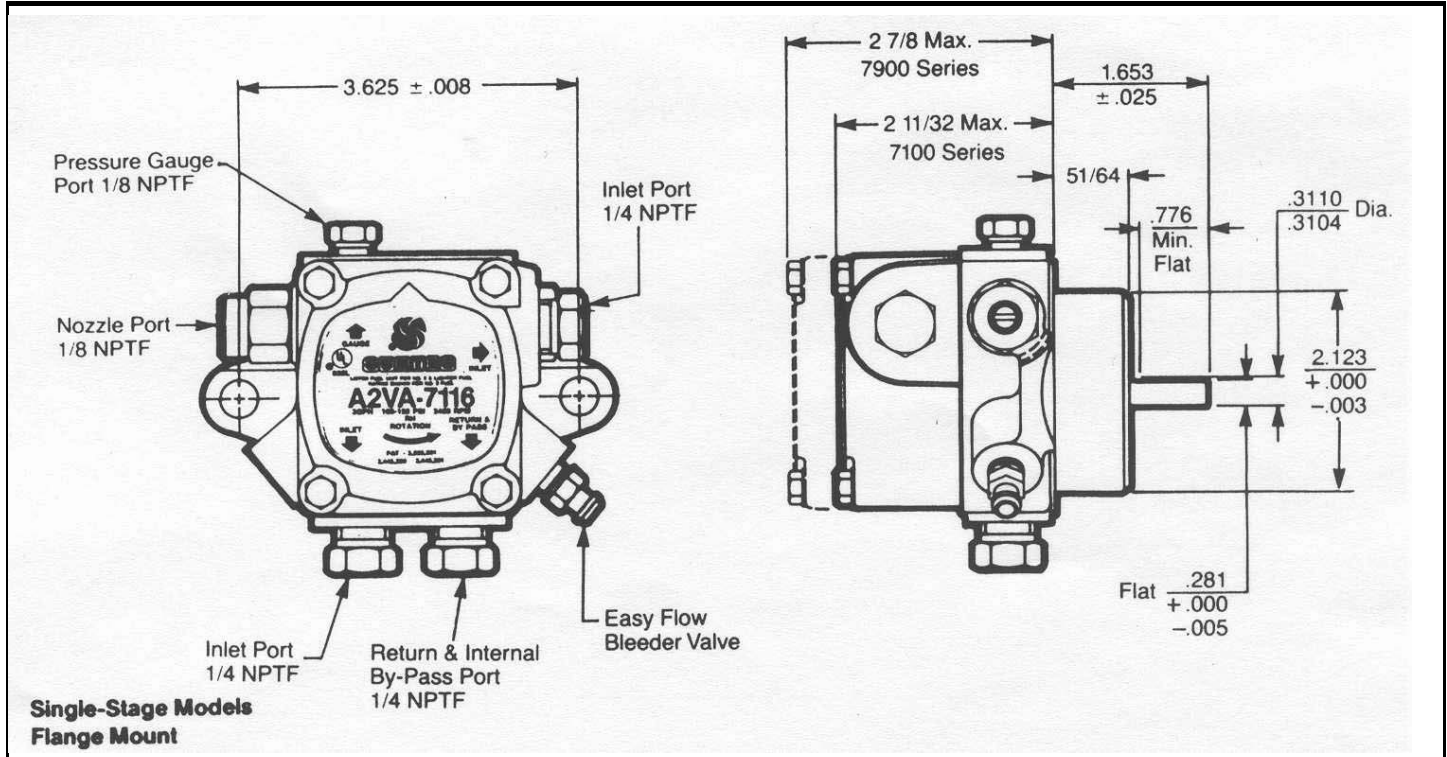

Model Number	RPM	Rotation ¹	Nozzle Port Location ¹	Strainer & Nozzle Rating at 100 psi	Special Features
A1VA-7112	1725	R.H.	R.H.	3 gph	--
A1VB-7113	1725	R.H.	L.H.	3 gph	--
A1VC-7114	1725	L.H.	L.H.	3 gph	--
A1VD-7741	1725	L.H.	R.H.	3 gph	3-bolt mtg. hub
A1YA-7912	1725	R.H.	R.H.	7 gph	--
A2VA-3006					
A2VA-7142	2850	R.H.	R.H.	2.25 gph	--
A2VA-7116	3450	R.H.	R.H.	3 gph	--
A2VB-7117	3450	R.H.	L.H.	3 gph	--
A2VC-7118	3450	L.H.	L.H.	3 gph	--
A2VA-7416	3450	R.H.	R.H.	3 gph	Solenoid dumping fuel unit
A2YA-7743	3450/2850	R.H.	R.H.	7 gph	
A2YA-7916	3450	R.H.	R.H.	7 gph	3 gph at 200 psi
A2YA-7430	3450	R.H.	R.H.	3 gph	Solenoid dumping fuel unit
A2VD-7519	3450	L.H.	R.H.	3 gph	Solenoid dumping fuel unit .32mm hub
A2RA-7710	3450/100	R.H.	R.H.	2.5/4 gph	Waste oil application
A2RA-7736	3450/1725	R.H.	R.H.	2.5/2.5**gph	Waste oil application
A2RA-7737	3450/1725	R.H.	R.H.	2.5/2.5**gph	10-20 psi waste oil application
A1RA-7738	1725	R.H.	R.H.	2.5	Waste oil application
A2RA-7739	3450/1725	R.H.	R.H.	2.5/1.5 gph	30-50 psi waste oil

*Also apply to "-6" model numbers (shown on fuel unit).

For example: "7916-6," etc. ¹Viewed from shaft end.

**Use gage port for rated flow @ 1725 rpm, no cut off.

Note: All ports shown in diagram are reversed for left-hand nozzle fuel units.

**Typical Model Number Nomenclature
(Model A & Model B):***

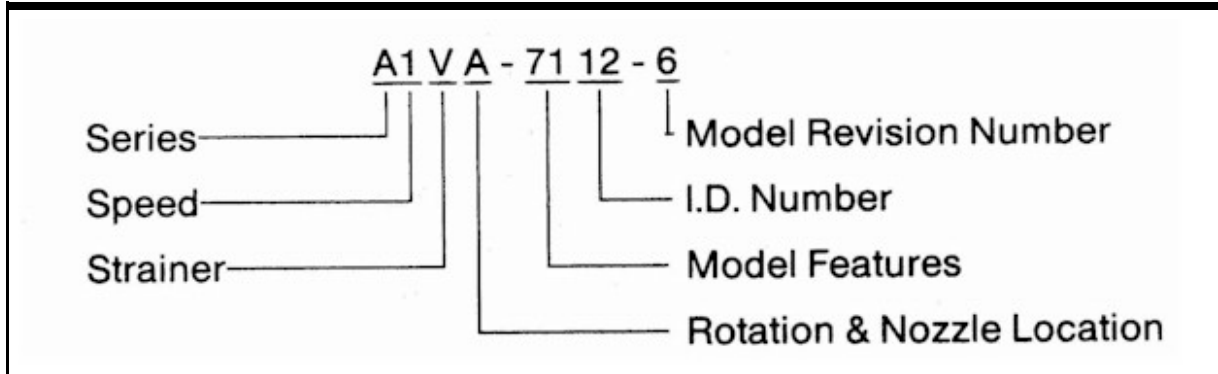

*The model number appears on the fuel unit label.

MODEL B-8000 • TWO-STAGE FUEL UNITS

- Two-pipe installations up to 17" hg. vacuum
- Lift or gravity feed applications with 10 psi maximum inlet/return pressure
- Capacities to 7 gph, except boost pumps
- Factory-set at 100 psi
- Pressure adjustable from 100 to 150 psi at 3450 rpm, 100 to 135 psi at 1725 rpm. Models available to 200 and 300 psi
- Choice of 1725, 2850, 3450 rpm
- Suitable for no.2, no.1 fuel oil, or kerosene
- Mounting in any position except upside down.



SPECIFICATION*/ORDERING INFORMATION

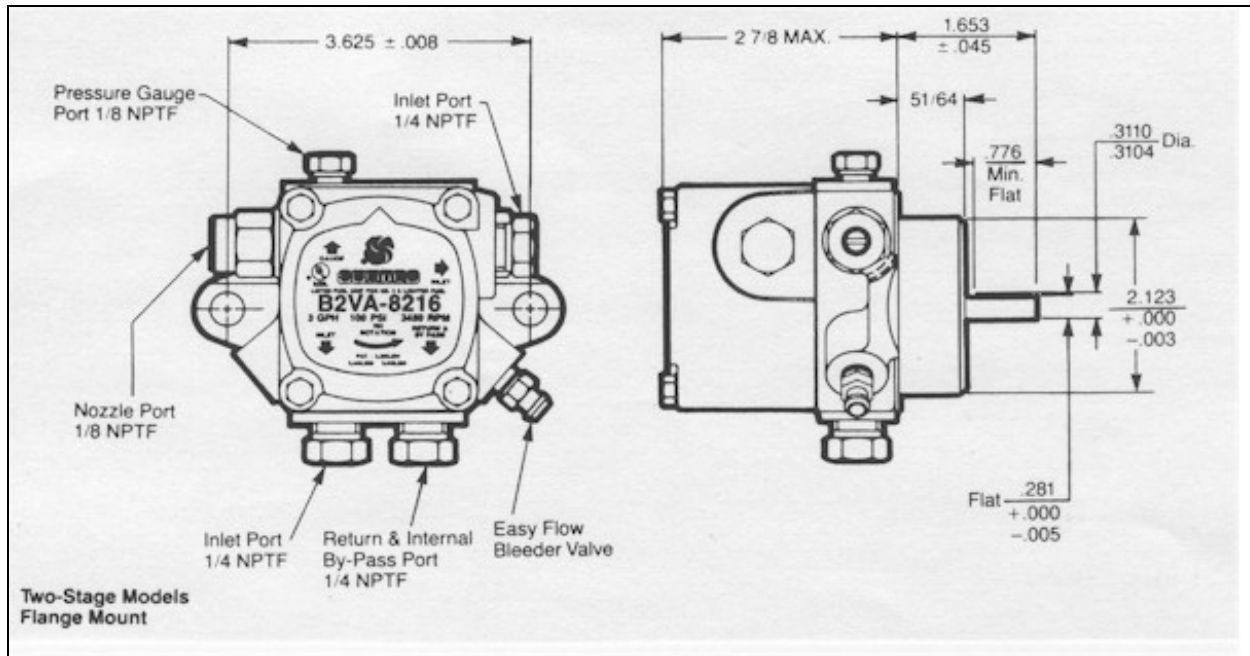

Model Number	RPM	Rotation ¹	Nozzle Port Location ¹	Strainer & Nozzle Rating at 100 psi	Special Features
B1VA-8212	1725	R.H.	R.H.	3 gph	--
B2VA-8216	3450	R.H.	R.H.	3 gph	--
B2YA-8916	3450	R.H.	R.H.	7 gph	3 gph at 200 psi
B2VA-8416	3450	R.H.	R.H.	3 gph	Solenoid dumping fuel unit
B2VA-8241	3450	R.H.	R.H.	--	Boost pump, 20 gph at 10-20 psi
B2VA-8242	2850	R.H.	R.H.	2.25 gph	--

*Also apply to “-8” model numbers (shown on fuel unit). For example: “8212-6,” etc.

¹Viewed from shaft end.

**MODEL B-8200 • TWO-STAGE HIGH CAPACITY
HIGH PRESSURE (NOT PICTURED) AND
MODEL B-8800 • TWO-STEP TWO-STAGE**

- Two-pipe installations up to 17" hg. Vacuum
- Lift or gravity feed applications with 10 psi maximum inlet/return pressure
- Adjustable manual or automatic high/low firing
- High efficiency burner applications
- Capacities to 23 gph
- Pressure adjustable (100 to 200 psi low fire, 200-300 psi high fire)
- For no. 2 fuel oil. For other fuels, consult factory
- Two-bolt flange mounting in any position except upside down.



SPECIFICATIONS*/ORDERING INFORMATION

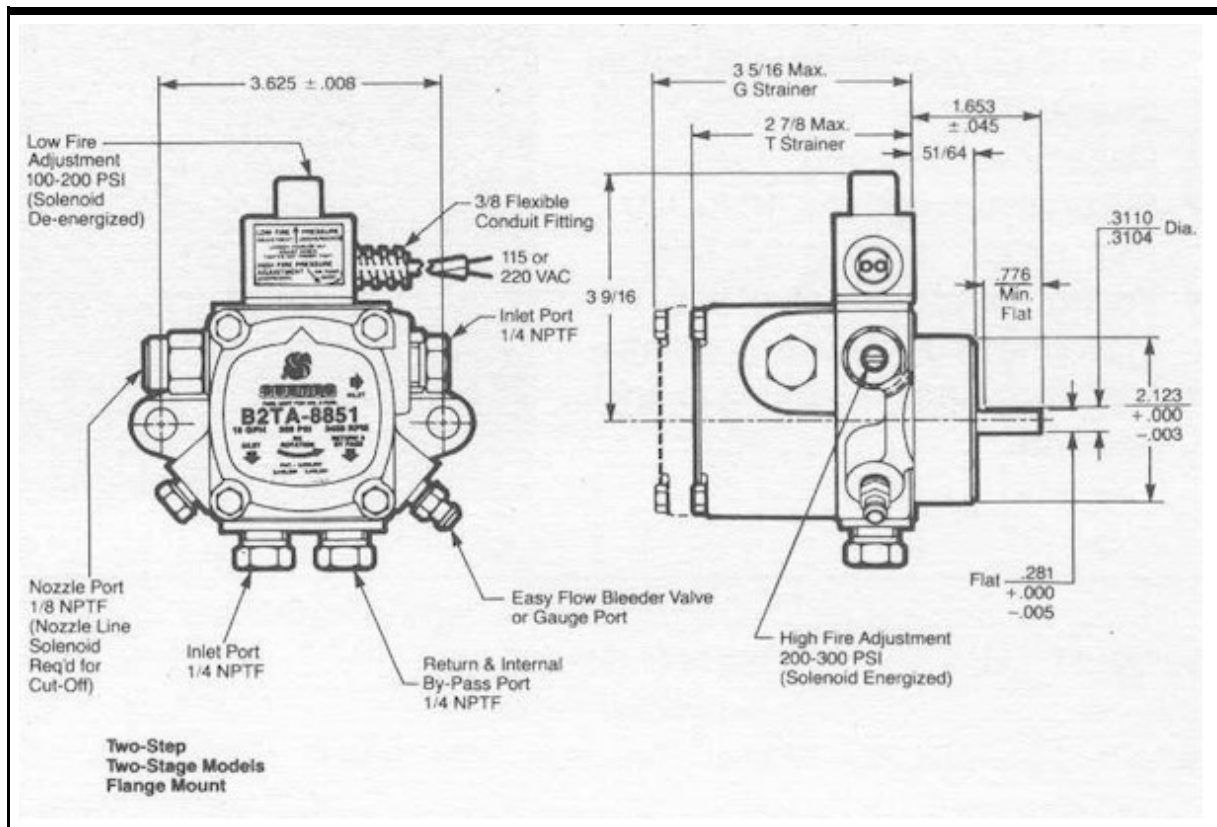

Model Number	RPM	Rotation ¹	Nozzle Port Location ¹	Strainer & Nozzle Rating at 300 psi
High-Capacity Units				
B2VA-8243	3450	R.H.	R.H.	3 gph ²
B2TA-8245	3450	R.H.	R.H.	16 gph
B2TA-8248	3450	R.H.	R.H.	8 gph ³
Two-Step Units				
B2TA-8850	3450	R.H.	R.H.	10 gph
B2TA-8851	3450	R.H.	R.H.	16 gph
B2GA-8852	3450	R.H.	R.H.	23 gph

*Also apply to “-8” model numbers (shown on fuel unit). For example: “8850-8,” etc.

¹Viewed from shaft end.

²At 130 psi.

³At 150 psi.

MODEL J • SINGLE-STAGE FUEL UNITS

- Single-pipe gravity feed installations
- Two-pipe lift installations to 12” hg. vacuum
- Lift or gravity feed applications with 10 psi maximum inlet/return pressure
- Capacities to 60 gph
- Six pressure options, 10 to 300 psi*
- For no. 4 and lighter fuel oils (gasoline and JP fuels, special)
- Hub and flange mounting in any position.

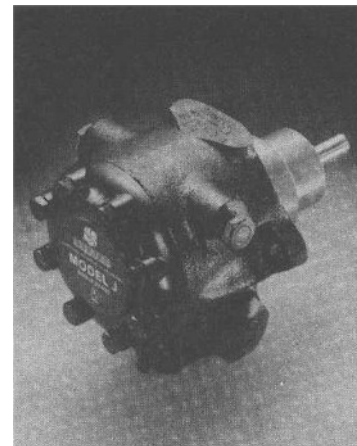

SPECIFICATION* /ORDERING INFORMATION

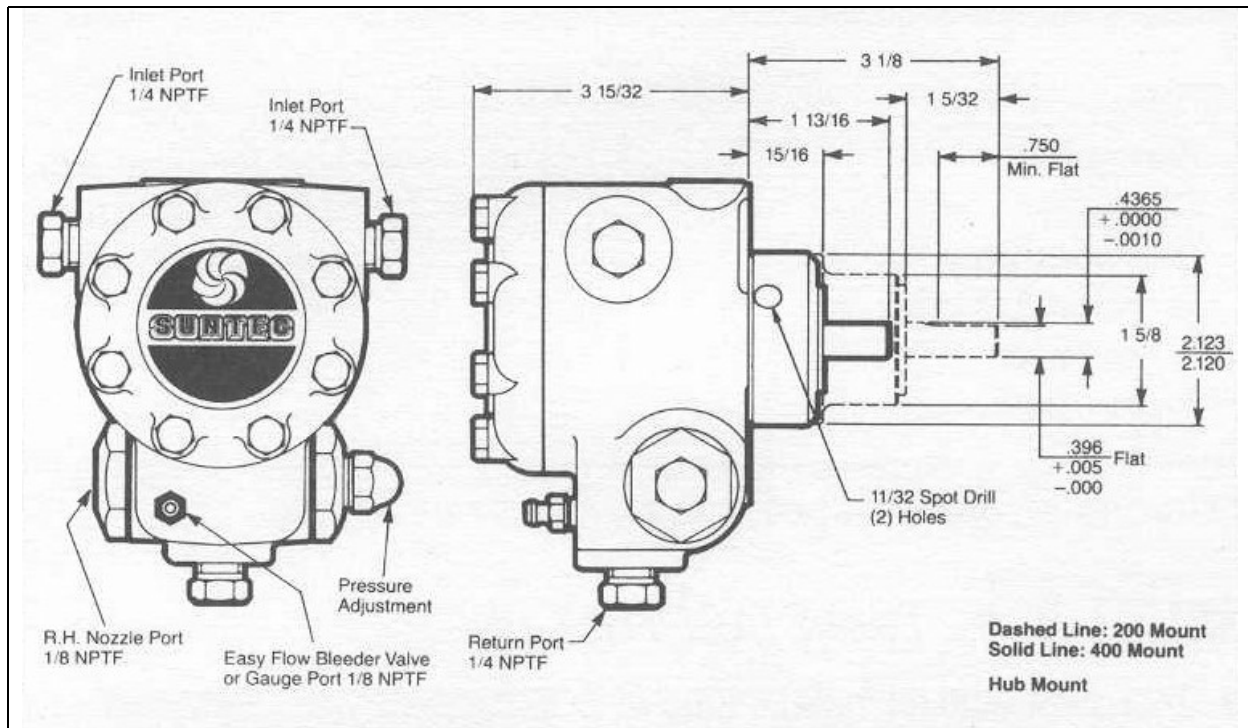

Model Number ¹	Piston Type	Maximum Firing Rate* (gph)			
		1725 rpm		3450 rpm	
		100 psi	300 psi ²	100 psi	300 psi ³
JJ2	Std.	--	--	3	--
JA2	Std.	--	--	7	--
JB2	Std.	--	--	10	--
J2	Std.	3	--	16	--
J3	Std.	7	--	20	--
	G	8	--	24	10
	N	9	--	26	14
J4	Std.	11	--	30	17
	N	13	--	33	23
J5	Std.	17	--	40	28
	N	19	5	46	32
J6	Std.	24	7	55	40
	N	26	10	60	45

*Special Pressure Spring Choices:

A = 20-40 psi

C = 150-300 psi

E = 10-20 psi

B = 75-200 psi

D = 40-80 psi

¹Do not adjust J2 and 3450 rpm-only models (JA, JB, JJ) to higher than 100 psi.

²Requires C spring (100-300 psi range).

³Requires C spring and hardened gear.

Typical Model Number Nomenclature (Model J & Model H):*

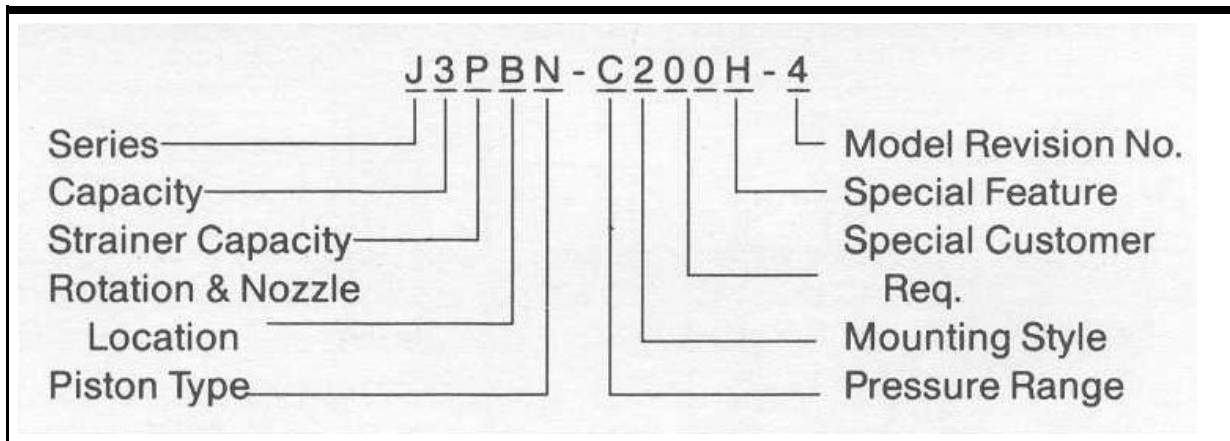

* The model number appears on the top of the fuel unit.

MODEL H TWO-STAGE FUEL UNITS

- Two-pipe high lift installations to 17" hg. vacuum
- Capacities to 83 gph
- Lift or gravity feed applications with 10 psi maximum inlet/return pressure
- Six pressure options, 10 to 300 psi*
- For no. 4 and lighter fuel oils (gasoline and JP fuels, special)
- Three hub and flange mounting options: Model H may be mounted with the valve horizontal at either the top or bottom. Valve may be mounted vertical provided the adjusting screw is at the top of CW rotation-left nozzle and CCW rotation-right nozzle models, or adjusting screw at bottom on CW rotation-right nozzle and CCW rotation-left nozzle models.



SPECIFICATIONS* /ORDERING INFORMATION

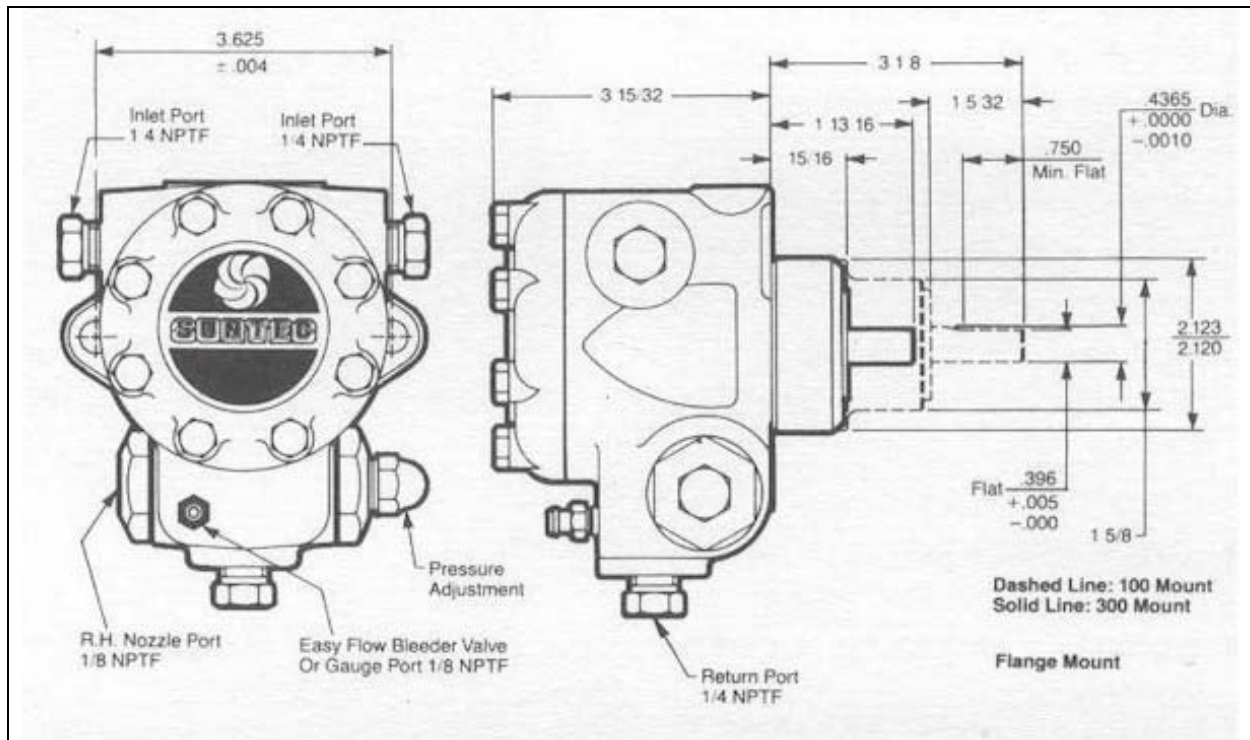

Model Number ¹	Piston Type	Maximum Firing Rate* (gph)			
		1725 rpm		3450 rpm	
		100 psi	300 psi ²	100 psi	300 psi ³
HA2	Std.	--	--	7	--
H2	Std.	3	--	16	--
H3	Std.	7	--	20	--
	G	8	--	24	10
H4	N	9	--	26	14
	Std.	11	--	30	17
H5	N	13	--	33	23
	Std.	17	--	40	28
H6	N	19	5	46	32
	Std.	24	7	55	40
H7	N	26	10	60	45
	Std.	40	17	--	--
H8	N	42	20	--	--
	Std.	80	47	--	--
	N	83	55	--	--

*Special Pressure Spring Choices:

A = 20-40 psi

C = 150-300 psi

E = 10-20 psi

B = 75-200 psi

D = 40-80 psi

¹Do not adjust H2 and 3450 rpm-only models (HA, HB, HH) to higher than 110 psi.

²Requires C spring (100-300 psi range).

³Requires C spring and hardened gear.

MODEL R & C • SHUT-OFF VALVES

- For instantaneous, redundant cutoff of fuel supply
- Provides back-up protection
- Closes when current to solenoid coil is interrupted
- Blocks oil flow to nozzle
- Delay or non-delay opening
- Two model choices: Model R mounts to fuel unit; Model C mounts to burner or other remote locations
- Easy installation
- Use with any fuel unit rated up to 16 gph
- Suitable for no. 2, no. 1 fuel oil or kerosene
- Mount in any position

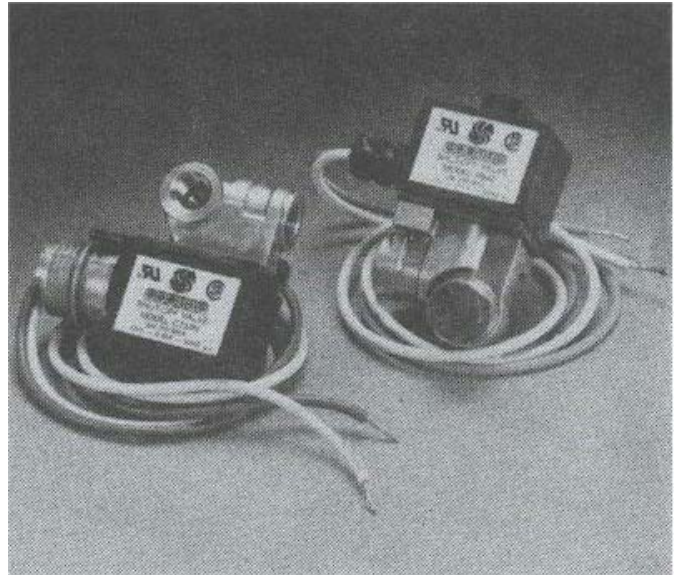

SPECIFICATIONS/ ORDERING INFORMATION

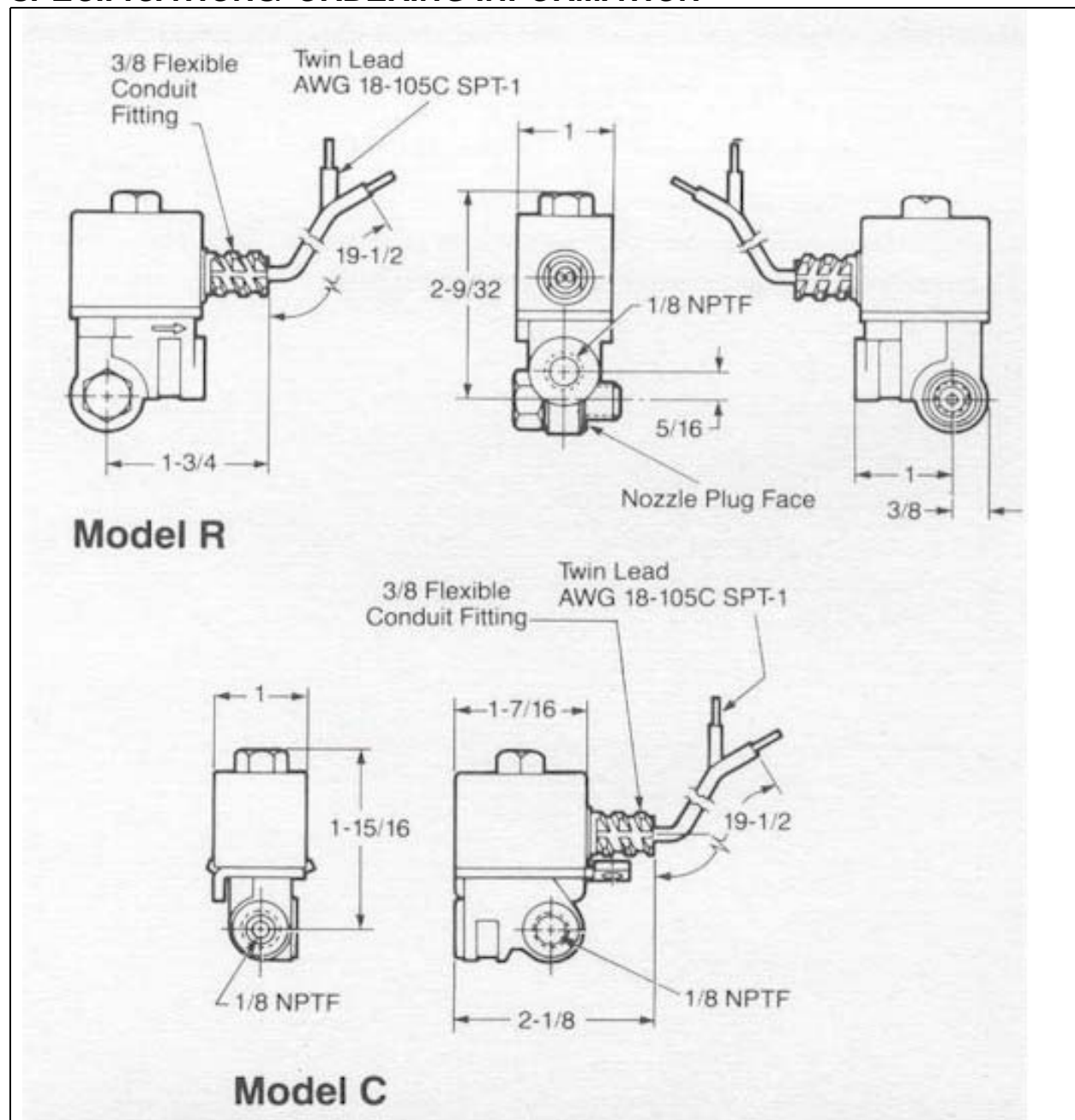

Valve Model No.		Opening Response	Voltage (50/60 Hz.)	Maximum Operating Pressure	Color Code	
Pump Mount	Burner Mount				Coil	Lead Wires
R642N	C642N	Non-Delay	115	300 psi	Black	Orange/White
R641D	C641D	Delay	115	150 psi	Grey	Orange/White
R753N	C753N	Non-Delay	220	300 psi	Black	Red/White
R261N	C261N	Non-Delay	24	300 psi	Green	Blue/Brown/ Yellow & Green

**Typical Model Number Nomenclature
(Model R & Model C):***

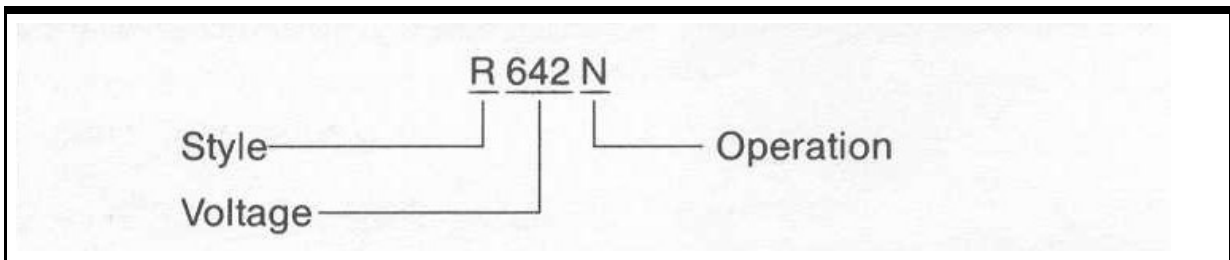

*The model number appears on the valve label.