

## Pressure Sensitive Multiple Gun Regulating Unloader

**Stainless Steel Models**      **7531**  
**7533, 7536**

**Brass Models**      **7534, 7535**

### FEATURES

- Maintains full system pressure while running in by-pass without full load on pump.
- Senses pressure built up from downstream flow changes and by-passes flow to protect pump from overpressure.
- Minimum pressure fluctuations with alternating use of multiple guns.
- Multiple ports for convenient mounting.
- Color coded spring for easy identification and simple change from one model to another.

### SPECIFICATIONS

	U.S. Measure	Metric Measure
<b>MODELS 7531 s - 7534 BB</b>		
Flow Range .....	1-21 gpm	(3.8-80 lpm)
Pressure Range.....	<b>400-2200 psi</b>	<b>(28-155 bar)</b>
Weight.....	2.9 lbs.	(1.31 kg)
<b>MODELS 7533 s - 7535 BB</b>		
Flow Range .....	1-21 gpm	(3.8-80 lpm)
Pressure Range.....	<b>800-4000 psi</b>	<b>(55-275 bar)</b>
Weight.....	2.9 lbs.	(1.31 kg)
<b>MODELS 7536 s</b>		
Flow Range .....	1-21 gpm	(3.8-80 lpm)
Pressure Range.....	<b>3000-5700 psi</b>	<b>(210-400 bar)</b>
Weight.....	2.9 lbs.	(1.31 kg)

### COMMON SPECIFICATIONS

Inlet Ports (2).....	1/2" NPTF	(1/2" NPTF)
Discharge Port.....	1/2" NPTF	(1/2" NPTF)
By-Pass Port .....	1/2" NPTF	(1/2" NPTF)
<b>Maximum Operating Temperatures:</b>		
Standard Buna o-rings.....	140°F	(60°C)
Standard Buna o-rings (intermittent) .....	195°F	(90°C)
Optional FPM o-rings.....	240°F	(116°C)
Dimensions.....	8.75 x 3.75 x 1.75"	(223 x 96 x 45 mm)

Unloader is stamped with European safety pressure.  
Use only at above specifications to assure proper unloader life and performance.  
For relief valve version add .100 to unloader model number.

### **⚠ CAUTIONS AND WARNINGS**

All High Pressure Systems require a primary pressure regulating device (i.e. regulator, unloader) and a secondary pressure relief device (i.e. pop-off valve, relief valve). Failure to install such relief devices could result in personal injury or damage to pump or property. CAT PUMPS does not assume any liability or responsibility for the operation of a customer's high pressure system.

Read all CAUTIONS and WARNINGS before commencing service or operation of any high pressure system. The CAUTIONS and WARNINGS are included in each service manual and with each Accessory Data sheet. CAUTIONS and WARNINGS can also be viewed online at [www.catpumps.com/cautions-warnings](http://www.catpumps.com/cautions-warnings) or can be requested directly from CAT PUMPS.

### **WARRANTY**

View the Limited Warranty on-line at [www.catpumps.com/warranty](http://www.catpumps.com/warranty).

## Read all CAUTIONS and WARNINGS before commencing service or operation of any high-pressure system

### SELECTION

These pressure sensitive regulating unloaders are designed for systems with single or multiple pumps, solenoid (gate) valves, nozzles, standard or "weep" guns.

**Note:** For multiple pump systems, it is best to use a pressure regulator not a pressure sensitive regulating unloader.

These pressure sensitive regulating unloaders should meet both the desired system flow (combined nozzle flow rate requirement) and the desired system pressure.

**NOTICE:** Operation below the minimum flow of the unloader causes the unloader to cycle. Operation above the maximum flows of the unloader causes premature unloader wear, cycling and prevents attaining desired system pressure.

### INSTALLATION

These unloaders operate properly when mounted in any direction, however, it is preferred to keep the plumbing to a minimum and the hex adjusting nut or adjustment handle easily accessible. The best mounting location is directly on the pump discharge manifold head.

There are two (2) inlet connections on these unloaders. Both are 1/2" NPTF ports and are located on the short extension side and bottom. An arrow and the word IN is cast into the body indicating the direction of flow. Liquid from the manifold discharge goes through these connections.

The discharge connection is a 1/2" NPTF hex fitting. An arrow and the word OUT is cast into the body indicating the direction of flow. Discharge plumbing for the spray guns, solenoid (gate) valves or nozzles are connected to this port.

The by-pass connection is a 1/2" NPTF port located on the side of the body. The word BY-PASS is cast into the body. By-Pass liquid is directed out of this port and can be routed to a reservoir (preferred method), or to a drain or to the pump inlet.

### OPERATION

These pressure sensitive regulating unloaders hold established system pressure in the discharge line when the trigger gun is closed or solenoid (gate) valve is closed or the nozzle is clogged, thus by-passing all unrequired flow. Squeezing the trigger gun or opening the solenoid (gate) valve will close the by-pass and return to established system pressure.

### PRESSURE ADJUSTMENT

1. Setting and adjusting the unloader pressure must be done with the system "on".

2. Start the system with unloader backed off to the lowest pressure setting (counterclockwise direction).

3. Squeeze the trigger and read the pressure on the gauge at the pump.

**Note:** Do not read the pressure at the gun or nozzle.

4. If more pressure is desired, release the trigger, turn hex adjusting nut or adjustment handle one quarter turn in clockwise direction.

5. Squeeze the trigger and read the pressure.

6. Repeat this process until desired system pressure is attained.

7. Once the desired system pressure is reached, stop turning the hex adjusting nut or adjustment handle.

**Note:** Pressure is not set at the factory.

**Notice:** A minimum by-pass flow of 5% of the unloader rated flow capacity is required for proper unloader performance. If the entire out is directed through the nozzle (zero by-pass) the "cushioning" feature of the by-pass liquid is eliminated and the unloader can prematurely wear or malfunction.

8. If desired system pressure cannot be reached, review TROUBLESHOOTING chart.

9. When servicing existing systems, follow adjustment procedures as stated above.

**Note:** Do not adjust unloader pressure setting to compensate for a worn nozzle. Check the nozzle as part of the regular maintenance and replace if worn.

**Note:** A secondary pressure safety relief device (i.e. pop-off valve, safety valve) should be used along with this pressure sensitive regulating unloader. Final adjustment for the relief valve should relieve at 200 psi above the system operating pressure.

**Note:** By removing the check valve and spring, these unloaders can function as a secondary relief valve.

### TYPICAL UNLOADER INSTALLATION

- 1 Pressure Gauge
- 2 Relief Valve  
Shown as a secondary safety relief valve
- 3 Pulsation Dampener
- 4 Pressure Regulator Regulating Unloader
- 5 Triplex Plunger Pump

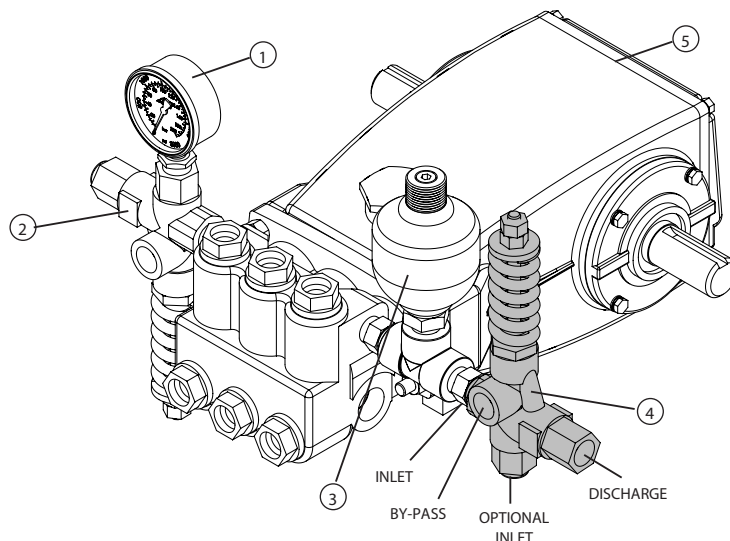

**Read all CAUTIONS and WARNINGS before commencing service or operation of any high-pressure system**

**SERVICING**

**Disassembly**

1. Disconnect by-pass, discharge and inlet plumbing from unloader.
2. Remove unloader from pump.
3. Secure body of unloader in a vise with hex adjusting nut or adjustment handle facing up.
4. Remove discharge fitting and O-ring, spring, and check valve with O-ring.
5. Examine check valve and discharge fitting for wear, spring for wear or fatigue and O-rings for cuts or wear and replace as needed.

**Note:** While the discharge fitting is removed, inspect sealing area where the check valve makes contact within the internal body of the unloader for grooves, pitting and wear. If damage is found, stop the repair and replace with complete new unloader. If not, proceed with disassembly.

6. Remove two (2) hex adjusting nuts by turning in a counterclockwise direction.
- Note:** If supplied with a adjustment handle, remove by turning in a counterclockwise direction.
7. Remove spring retainer and spring.
8. Examine spring and spring retainer for scale build up, fatigue or wear and replace as needed.
9. Drive out piston lock pin from piston stem.
10. Use wrench to unthread and remove piston retainer and piston stem together from main unloader body.
11. Examine piston stem and piston retainer for scale build up, scoring, pitting and wear and replace as needed. Examine O-rings and backup rings for cuts or wear and replace as needed.
12. Remove unloader body from vise and reposition in vise with bottom inlet port facing up.
13. Remove inlet fitting with O-ring, seat spring and ball.
14. Remove unloader body from vise and reposition in vise with bottom inlet port facing down.
15. Drive out seat and O-ring from the top side.
16. Examine seat, seat spring and ball for scale build up, scoring and wear and replace as needed. Examine O-rings for cuts or wear and replace as needed.

**Reassembly**

1. Remove unloader body from vise and reposition in vise with bottom inlet port facing up.
2. Lubricate and install O-ring onto outside diameter of seat.
3. Place seat with O-ring into unloader body with small inside diameter hole facing up.
4. Place ball onto seat and then spring.
5. Lubricate and install O-ring onto inlet fitting. Thread in inlet fitting by hand and tighten.
6. Remove unloader body from vise and reposition in vise with bottom inlet fitting facing down.
7. Lubricate and install backup ring, then O-ring, and finally second backup ring onto groove of piston stem.
8. Lubricate and install O-ring and then backup ring over threaded end of piston stem and slide both parts all the way to bottom of piston stem.
9. Lubricate and install O-ring onto piston retainer.
10. Place threaded end of piston retainer over the threaded end of the piston stem.
11. Place piston retainer and piston stem assembly into unloader body with threaded end of piston stem facing up. Thread piston retainer into unloader body by hand and tighten with wrench.
12. Align hole in piston stem with vertical slot of piston retainer.
13. Drive in piston lock pin.
14. Apply Loctite® 242® to the bottom threads of the piston stem.
15. Hand thread one (1) hex nut onto piston stem and tighten with wrench.
16. Place spring over piston stem and then spring retainer onto spring with stepped surface facing down.
17. Hand thread two (2) hex nuts or adjustment handle onto piston stem.
18. Lubricate O-ring on check valve. Insert check valve with O-ring facing into unloader body. Place spring onto check valve.
19. Lubricate O-ring on discharge fitting. Hand thread into unloader body and tighten with wrench.
20. Remove unloader from vise.
21. Re-install unloader onto pump.
22. Reconnect by-pass, discharge and inlet plumbing to unloader.
23. Proceed to PRESSURE ADJUSTMENT.

Loctite and 242 are registered trademarks of the Henkel Corporation.

**TROUBLESHOOTING**

Unloader cycles	<ul style="list-style-type: none"> <li>● Check for leak downstream of unloader.</li> <li>● Worn O-ring or check valve.</li> <li>● Air in system, poor connection.</li> <li>● O-ring in gun worn.</li> <li>● Insufficient flow through unloader.</li> </ul>
Liquid leaking from bottom fitting	<ul style="list-style-type: none"> <li>● O-ring for fitting cut or worn.</li> <li>● O-ring for seat cut or worn.</li> </ul>
Liquid leaking from middle	<ul style="list-style-type: none"> <li>● O-ring for piston worn or cut.</li> <li>● O-rings for piston stem worn or cut.</li> </ul>
Unloader will not come up to pressure	<ul style="list-style-type: none"> <li>● Not properly sized for system pressure.</li> <li>● Foreign material in unloader. Clean filter.</li> <li>● Piston stem O-rings worn.</li> <li>● Nozzle worn.</li> <li>● Insufficient flow to pump.</li> </ul>
Extreme pressure spikes	<ul style="list-style-type: none"> <li>● Adjusting nut turned completely into unloader.</li> <li>● Restricted by-pass or no by-pass.</li> <li>● System flow exceeds unloader rating.</li> </ul>
Filtration	<ul style="list-style-type: none"> <li>● Clean filter on regular schedule to avoid cavitation.</li> </ul>

**PRESSURE READING**

Approximate Pressure Reading at Gauge	Gauge Between Pump/Unloader	Gauge Between Unloader/Gun-Nozzle-Valve
System in operation (gun open)	system pressure	system pressure
System in by-pass (all guns, valves closed)	low pressure 0-150 PSI	system pressure +200 PSI

## EXPLODED VIEW

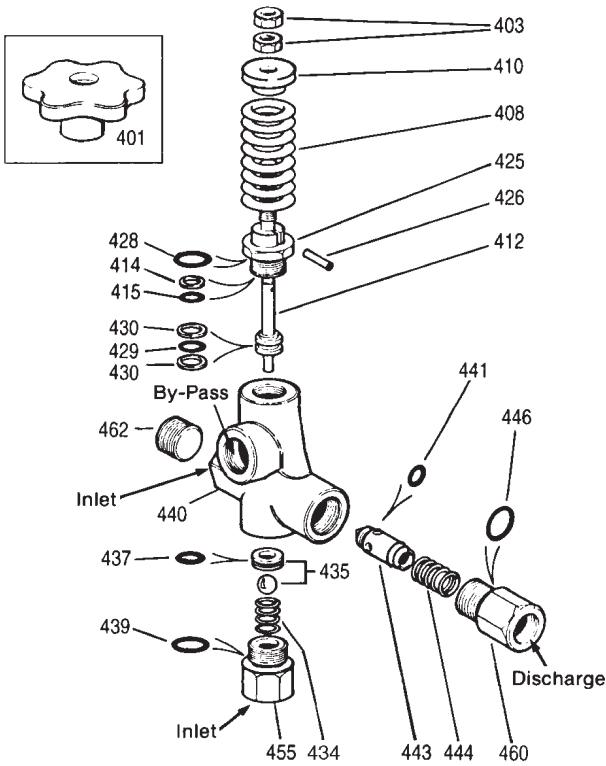

## CUTAWAY

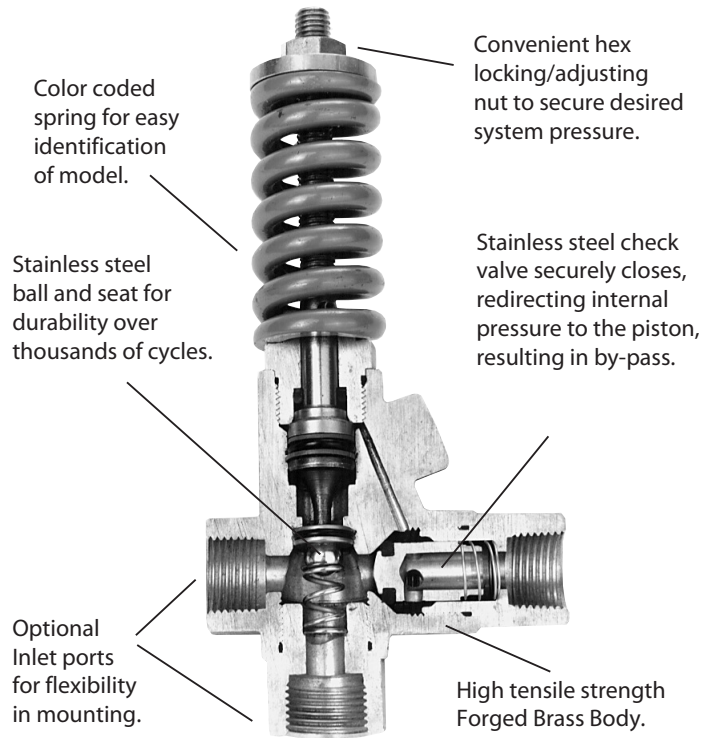

## PARTS LIST

ITEM	DESCRIPTION	MODEL NUMBER					QTY					
		7534 BB	MATL	7535 BB	MATL	7531 S		MATL	7533 S	MATL	7536 S	MATL
401	Handle, Adjustment	33045	NY	33045	NY	33045	NY	33045	NY	33045	NY	1
403	Nut, Hex Adjusting (M10)	—	BBCP	—	BBCP	—	S	—	S	—	S	3
408	Spring- <b>White</b> (400-2200 PSI)	<b>32323</b>	<b>STL</b>	—	—	<b>32323</b>	<b>STL</b>	—	—	—	—	1
	Spring- <b>Blue</b> (800-4000 PSI)	—	—	<b>32324</b>	<b>STL</b>	—	—	<b>32324</b>	<b>STL</b>	—	—	1
	Spring- <b>Black</b> (3000-5700 PSI) (S only)	—	—	—	—	—	—	—	—	<b>32344</b>	<b>STL</b>	1
410	Retainer, Spring	30119	BB	30119	BB	30119	BB	30119	BB	30119	BB	1
412	Stem, Piston	<b>32329</b>	<b>S</b>	<b>32329</b>	<b>S</b>	<b>32339</b>	<b>S</b>	<b>32339</b>	<b>S</b>	<b>32339</b>	<b>S</b>	1
414	Back-up-Ring, Piston Stem	—	PTFE	—	PTFE	—	PTFE	—	PTFE	—	PTFE	1
415	O-ring, Piston Stem - 90D	—	NBR	—	NBR	—	NBR	—	NBR	—	NBR	1
		—	FPM	—	FPM	—	FPM	—	FPM	—	FPM	1
425	Retainer, Piston	<b>32671</b>	<b>BB</b>	<b>32671</b>	<b>BB</b>	<b>39055</b>	<b>S</b>	<b>39055</b>	<b>S</b>	<b>39055</b>	<b>S</b>	1
426	Pin, Piston Lock	32326	S	32326	S	32326	S	32326	S	32326	S	1
428	O-ring, Piston Retainer - 85D	32926	NBR	32926	NBR	32926	NBR	32926	NBR	32926	NBR	1
		—	FPM	—	FPM	—	FPM	—	FPM	—	FPM	1
429	O-ring, Piston Stem	—	NBR	—	NBR	—	NBR	—	NBR	—	NBR	1
		—	FPM	—	FPM	—	FPM	—	FPM	—	FPM	1
430	Back-up-Ring, Piston Stem	—	PTFE	—	PTFE	—	PTFE	—	PTFE	—	PTFE	2
434	Spring, Seat	32325	S	32325	S	32325	S	32325	S	32325	S	1
435	Ball and Seat Assembly	32327	S	32327	S	32327	S	32327	S	32327	S	1
437	O-ring, Seat - 90D	—	NBR	—	NBR	—	NBR	—	NBR	—	NBR	1
		—	FPM	—	FPM	—	FPM	—	FPM	—	FPM	1
439	O-ring, Inlet Fitting - 85D	32926	NBR	32926	NBR	32926	NBR	32926	NBR	32926	NBR	1
		—	FPM	—	FPM	—	FPM	—	FPM	—	FPM	1
440	Body	—	FBB	—	FBB	—	S	—	S	—	S	1
441	O-ring, Check Valve	—	NBR	—	NBR	—	NBR	—	NBR	—	NBR	1
		—	FPM	—	FPM	—	FPM	—	FPM	—	FPM	1
443	Valve, Check w/NBR O-ring	<b>32328</b>	<b>BB</b>	<b>32328</b>	<b>BB</b>	<b>32338</b>	<b>S</b>	<b>32338</b>	<b>S</b>	<b>32338</b>	<b>S</b>	1
444	Spring, Check Valve	32332	S	32332	S	32332	S	32332	S	32332	S	1
446	O-ring, Discharge Fitting - 85D	32926	NBR	32926	NBR	32926	NBR	32926	NBR	32926	NBR	1
		—	FPM	—	FPM	—	FPM	—	FPM	—	FPM	1
455	Fitting, Inlet (1/2" NPT)	<b>32322</b>	<b>BB</b>	<b>32322</b>	<b>BB</b>	<b>32342</b>	<b>S</b>	<b>32342</b>	<b>S</b>	<b>32342</b>	<b>S</b>	1
460	Fitting, Discharge (1/2" NPT)	<b>32331</b>	<b>BB</b>	<b>32331</b>	<b>BB</b>	<b>32345</b>	<b>S</b>	<b>32345</b>	<b>S</b>	<b>32345</b>	<b>S</b>	1
462	Plug, Inlet	<b>30533</b>	<b>BB</b>	<b>30533</b>	<b>BB</b>	—	S	—	S	—	S	1
468	Kit, (Incls: 414,415,416,428,429,430,437,439,441,446)	32346	NBR	32346	NBR	32346	NBR	32346	NBR	32346	NBR	1
—	Kit, (Incls: 414,415,416,428,429,430,437,439,441,446)	33346	FPM	33346	FPM	33346	FPM	33346	FPM	33346	FPM	1

**Bold print part numbers are unique to a particular model. Italics are optional items.**

MATERIAL CODES (Not Part of Part Number): BB=Brass BBCP=Brass/Chrome Plated FBB=Forged Brass  
FPM=Fluorocarbon NBR=Medium Nitrile (Buna-N) NY=Nylon PTFE=Pure Polytetrafluoroethylene S=304SS STL=Steel



### CAT PUMPS

1681 - 94TH LANE N.E. MINNEAPOLIS, MN 55449-4324  
PHONE (763) 780-5440 — FAX (763) 780-2958  
e-mail: techsupport@catpumps.com  
www.catpumps.com