

Model 5CP4120CSS Shown
(Rails sold separately)

FEATURES

- Industrial triplex design offers reliability and versatility.
- Ultra-compact direct-drive mount to motor using bell housing and flexible coupling.
- Optional belt-drive for precision flow setting.
- Press-in seal cases for easy servicing.
- Side and rear oil gauge for easy maintenance.
- Low pressure seals and V-packings are completely lubricated and cooled to increase pump life.

5CP Plunger Pump

Standard Model

5CP4120CSS

SPECIFICATIONS

	U.S.	Metric
Flow.....	4.5 gpm	(17 lpm)
Pressure Range.....	100-4000 psi	(7-275 bar)
Inlet Pressure Range.....	-2.5 to 60 psi	(-2 to 4 bar)
Pump RPM.....	1750 rpm	(1750 rpm)
Bore.....	0.590"	(15 mm)
Stroke.....	0.787"	(20 mm)
Crankcase Capacity.....	17 oz.	(0.51 l)
Max. Liquid Temperature.....	160°F	(71°C)
Above 130°F call Cat Pumps for inlet conditions and elastomer recommendations.		
Inlet Ports (2).....	1/2" NPTF	(1/2" NPTF)
Discharge Ports (2).....	3/8" NPTF	(3/8" NPTF)
Shaft Diameter.....	0.787"	(20 mm)
Weight.....	19.9 lbs.	(9 kg)
Dimensions.....	10.6 x 8.9 x 5.7"	(270 x 226.5 x 146 mm)

⚠ CAUTIONS AND WARNINGS

All High Pressure Systems require a primary pressure regulating device (i.e. regulator, unloader) and a secondary pressure relief device (i.e. pop-off valve, relief valve). Failure to install such relief devices could result in personal injury or damage to pump or property. CAT PUMPS does not assume any liability or responsibility for the operation of a customer's high pressure system.

Read all CAUTIONS and WARNINGS before commencing service or operation of any high pressure system. The CAUTIONS and WARNINGS are included in each service manual and with each Accessory Data sheet. CAUTIONS and WARNINGS can also be viewed online at www.catpumps.com/cautions-warnings or can be requested directly from CAT PUMPS.

WARRANTY

View the Limited Warranty on-line at www.catpumps.com/warranty.

ELECTRIC HORSEPOWER REQUIREMENTS

MODEL	FLOW		PRESSURE						MOTOR PULLEY SIZE	
			psi 1500	psi 2000	psi 2500	psi 3000	psi 3500	psi 4000	rpm	Pulley O.D.
	u.s. gpm	lpm	bar 105	bar 140	bar 175	bar 210	bar 245	bar 275		
5CP4120CSS	4.5	17	4.6	6.2	7.7	9.2	10.8	12.3	1750	Direct-Drive

DETERMINING THE PUMP RPM	$\frac{\text{Rated gpm}}{\text{Rated rpm}}$	=	$\frac{\text{"Desired" gpm}}{\text{"Desired" rpm}}$
DETERMINING THE REQUIRED H.P.	$\frac{\text{gpm} \times \text{psi}}{1460}$	=	Electric Brake H. P. Required
DETERMINING MOTOR PULLEY SIZE	$\frac{\text{Motor Pulley O.D.}}{\text{Pump rpm}}$	=	$\frac{\text{Pump Pulley O.D.}}{\text{Motor rpm}}$

See complete Drive Packages [Incls: Pulleys, Belts, Hubs, Key] Tech Bulletin 003.
Refer to pump **Service Manual** for repair procedure and additional technical information.

PARTS LIST

ITEM	PN	MATL	DESCRIPTION	QTY
2	30057	STL	Key (M6x6x25)	1
5	126542	STCP R	Screw, HHC, Sems (M8x16)	8
8	46910	AL	Cover, Bearing	1
10	14028	NBR	O-Ring, Bearing Cover - 70D	2
11	43222	NBR	Seal, Oil, Crankshaft - 70D	1
15	14480	STL	Bearing, Ball	2
20	48742	TNM	Rod, Connecting Assy	3
25	49773	FCM	Crankshaft, Single End (M20)	1
30	49776	AL	Cover, Bearing	1
31	127409	—	Cap, Vented W/O-Ring (Rain Cap)	1
32	46798	—	Cap, Oil Filler, Domed	1
33	14179	NBR	O-Ring, Oil Filler Cap - 70D	1
37	92241	—	Gauge, Oil, Bubble w/Gasket - 80D	2
38	44428	NBR	Gasket, Flat, Oil Gauge - 80D	2
40	125824	STCP R	Screw, HHC, Sems (M6x16)	4
48	25625	STCP	Plug, Drain (1/4"x19BSP)	1
49	23170	NBR	O-Ring, Drain Plug - 70D	1
50	46940	AL	Cover, Rear	1
51	14044	NBR	O-Ring, Rear Cover	1
53	48617	AL	Crankcase	1
64	46746	CM	Pin, Crosshead	3
65	48458	BBNP	Rod, Plunger	3
70	46838	NBR	Seal, Oil, Crankcase - 70D	3
75	43900	S	Slinger, Barrier	3
88	45697	S	Washer, Keyhole (M18x10)	3
90	49906	CC	Plunger (M15 x 41)	3
98	46730	NBR	Washer, Seal - 90D	3
99	49907	S	Retainer, Plunger w/Stud (M6)	3
100	46749	PVDF	Retainer, Seal	3
106	49913	NBR	Seal, LPS w/SS-Spg	3
120	49912	BB	Case, Seal (Press-in-style)	3
121	13980	NBR	O-Ring, Seal Case - 70D	3
122	49944	UHMW	Ring, Support	3
125	49910	SNG	V-Packing	3
128	49990	D	Adapter, Male	3
139	22179	BBCP	Plug, Inlet (1/2"NPTM)	1
160	11346	NBR	O-Ring, Inlet Seat - 70D	3
161	49918	S	Seat Inlet	3
162	49844	PTFE	Back-up-Ring, Discharge Seat	3
163	49845	NBR	O-Ring, Discharge Seat - 70D	3
164	49917	S	Seat, Discharge	3
166	46429	S	Valve	6
167	43750	S	Spring	6
168	49847	PVDF	Retainer, Spring, Inlet	3
169	44565	PVDF	Retainer, Spring, Discharge	3
172	26089	NBR	O-Ring, Valve Plug - 80D	3
174	49920	BB	Plug, Valve	3
185	49863	FBB	Manifold, Head	1
188	87868	STZP	Screw, HSH (M8 x 107)	8
196	22187	BBCP	Plug, Discharge (3/8"NPTM)	1
255	30243	STZP	Mount, Direct	1
260	30611	STZP R	Mount, Rail, Assy (4.22")	1
	30613	STZP R	Mount, Rail, Assy (5.02")	1
	76513	STZP R	Mount, Rail, Assy (5.52")	1
275	30944	STL	Assembly, Hub & Key (Incls: 30945, 30057)	1
283	76334	—	Kit, Oil Indicator (3/8" x 24") (See Individual Data Sheet)	1
	34334	—	Kit, Oil Drain (3/8" x 24") (See Individual Data Sheet)	1
299	—	FBB	Head, Complete	1
300	76979	NBR	Kit, Seal (Incls: 98,106,121,125,128)	1
310	77026	NBR	Kit, Valve Preassembled (Incls: 160 -164,166-169,172)	1
350	30696	STZP	Pliers, Reverse	1
400	7850	BB	Modular Unloader (See Individual Data Sheet)	1
—	6107	—	Oil, Bottle (21 oz.) ISO 68 Hydraulic (Fill to specified crankcase capacity prior to start-up)	1

Italics are optional items. R Components comply with RoHS Directive.

*Review individual parts in each kit for material code identification.

View Tech Bulletins 002, 003, 024, 036, 043, 053, 060, 061, 064, 073, 074, 077, 078 and 083 for additional information.

MATERIAL CODES (Not Part of Part Number): AL=Aluminum BB=Brass BBCP=Brass/Chrome Plated

BBNP=Brass/Nickel Plated CC=Ceramic CM=Chrome-moly D=Acetal FBB=Forged Brass FCM=Forged Chrome-moly NBR=Medium Nitrile (Buna-N)

PTFE= Polytetrafluoroethylene PVDF=Polyvinylidene Fluoride S=304SS SNG=Special Blend (Buna) STL=Steel STCP=Steel/Chrome Plated

STZP=Steel/Zinc Plated TNM=Special High Strength UHMW=Ultra High Molecular Weight Polyethylene

EXPLODED VIEW

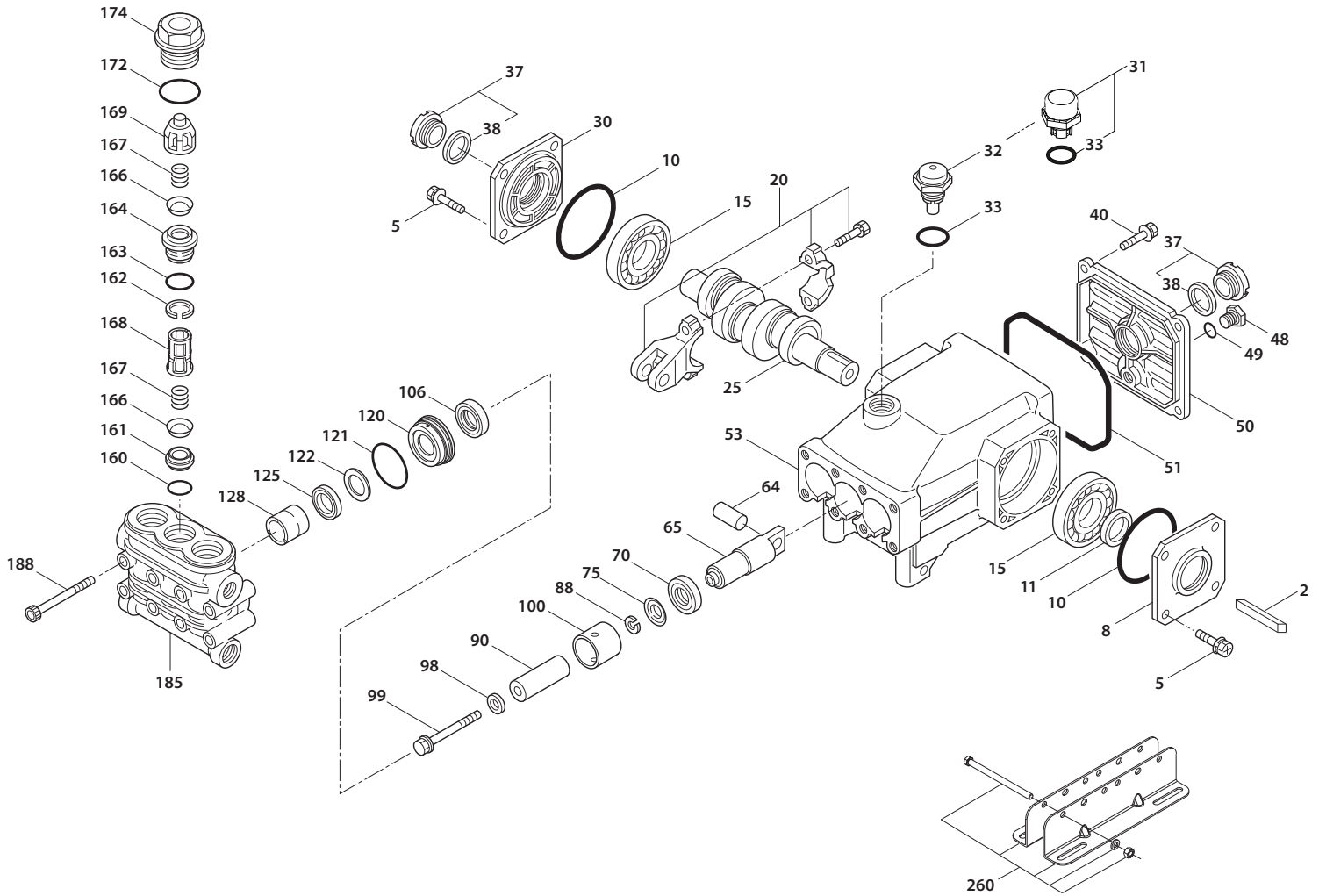

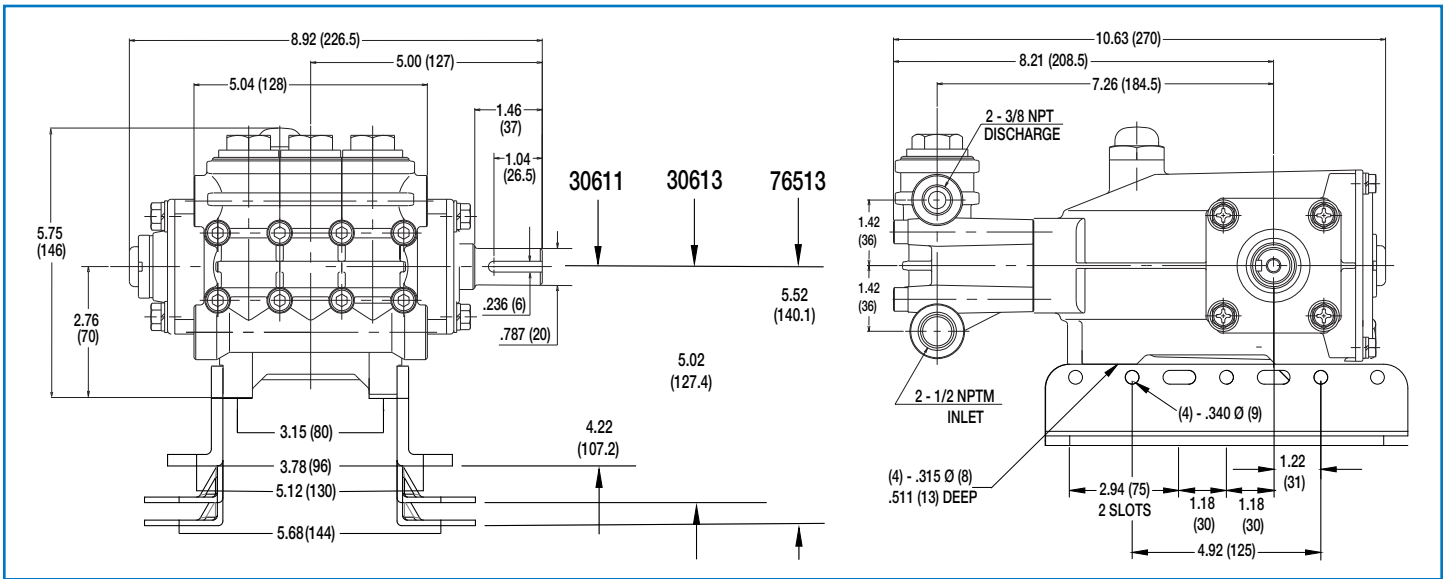

Model 5CP4120CSS



CAT PUMPS
 1681 - 94TH LANE N.E. MINNEAPOLIS, MN 55449-4324
 PHONE (763) 780-5440 — FAX (763) 780-2958
 e-mail: techsupport@catpumps.com
 www.catpumps.com