

Model 2530.44101 Shown  
(Rails sold separately)

## FEATURES

- Designed for continuous-duty performance for triethylene glycol (TEG) gas dehydration where low life cycle costs are a must.
- Field tested, high pressure triplex pump configured for TEG temperatures up to 240° F (116° C).
- Positive displacement technology for optimum energy efficiency.

## 25 Frame Plunger Pump Triethylene Glycol (TEG) Dehydration

**Standard  
Model**

**2530.44101**

**Stainless Steel  
Model**

**2531.44101**

### SPECIFICATIONS

	U.S. Measure	Metric Measure
Flow.....	25 gpm	(95 lpm)
Pressure Range.....	100 to 1000 psi	(7 to 70 bar)
RPM.....	1025 rpm	(1025 rpm)

### ALTERNATE SPECIFICATIONS

Flow.....	21 gpm	(80 lpm)
Pressure Range.....	100 to 1200 psi	(7 to 85 bar)
RPM.....	860 rpm	(860 rpm)

### COMMON SPECIFICATIONS

Inlet Pressure Range.....	Flooded to 70 psi	(Flooded to 4.9 bar)
Bore.....	1.260"	(32 mm)
Stroke.....	1.516"	(38.5 mm)
Crankcase Capacity.....	.84 oz.	(2.5 l)
Maximum Liquid Temperature .....	240°F	(116°C)
Inlet Ports (2).....	1-1/4" NPTF	(1-1/4" NPTF)
Discharge Ports (2).....	3/4" NPTF	(3/4" NPTF)
Pulley Mounting .....	Either Side	(Either Side)
Shaft Diameter .....	1.181"	(30 mm)
Weight.....	82 lbs.	(37.1 kg)
Dimensions.....	19.11 x 15.04 x 9.25"	(485.44 x 382 x 235 mm)

### ELECTRIC HORSEPOWER REQUIREMENTS

MODEL	FLOW		PRESSURE			RPM
	U.S. gpm	lpm	psi 800 bar 55	psi 1000 bar 70	psi 1200 bar 85	
<b>2530.44101</b>	25	95	13.7	17.1	N/A	1025
<b>2531.44101</b>	21	80	11.5	14.4	17.3	860

<b>DETERMINING THE PUMP R.P.M.</b>	Rated gpm Rated rpm	=	"Desired" gpm "Desired" rpm
<b>DETERMINING THE REQUIRED H.P.</b>	gpm x psi 1460	=	Electric Brake H. P. Required
<b>DETERMINING MOTOR PULLEY SIZE</b>	Motor Pulley O.D. Pump rpm	=	Pump Pulley O.D. Motor rpm

See complete Drive Packages [Incls: Pulleys, Belts, Hubs, Key] Tech Bulletin 003.  
Refer to pump **Service Manual** for repair procedure and additional technical information.

### ⚠ CAUTIONS AND WARNINGS

All High Pressure Systems require a primary pressure regulating device (i.e. regulator, unloader) and a secondary pressure relief device (i.e. pop-off valve, relief valve). Failure to install such relief devices could result in personal injury or damage to pump or property. CAT PUMPS does not assume any liability or responsibility for the operation of a customer's high pressure system.

Read all CAUTIONS and WARNINGS before commencing service or operation of any high pressure system. The CAUTIONS and WARNINGS are included in each service manual and with each Accessory Data sheet. CAUTIONS and WARNINGS can also be viewed online at [www.catpumps.com/cautions-warnings](http://www.catpumps.com/cautions-warnings) or can be requested directly from CAT PUMPS.

### WARRANTY

View the Limited Warranty on-line at [www.catpumps.com/warranty](http://www.catpumps.com/warranty).

## PARTS LIST

ITEM	PART NUMBER		DESCRIPTION		QTY	
	2530.44101	MATL	2531.44101	MATL		
5	<b>126544</b>	<b>STCP R</b>	<b>125753</b>	<b>S</b>	Screw, HHC, Sems (M8x25)	8
8	27773	AL	27773	AL	Cover, Bearing	2
10	76772	FPM	76772	FPM	O-Ring, Bearing Cover - 75D	2
11	76771	FPM	76771	FPM	Seal, Oil, Crankshaft - 70D	2
15	26512	STL	26512	STL	Bearing, Ball	2
20	48613	TNM	48613	TNM	Rod, Connecting	3
21	126562	STCP R	126562	STCP R	Washer, Locking	3
25	48704	FCM	48704	FCM	Crankshaft - Dual End (38.5mm)	1
31	76411	BB	76411	BB	Adapter, 3/4" NPT	1
32	992623	BB	992623	BB	Nipple, Close 3/4" NPT	1
33	76331	STCP	76331	STCP	Cap, Vented	1
38	26996	FPM	26996	FPM	O-Ring, Dipstick - 70D	1
39	76769	AL	76769	AL	Dipstick	1
40	<b>126544</b>	<b>STCP R</b>	<b>125753</b>	<b>S</b>	Screw, HHC, Sems (M8x25)	8
48	25625	STCP	25625	STCP	Plug, Drain (1/4"x19BSP)	1
49	30322	FPM	30322	FPM	O-Ring, Drain Plug	1
50	27768	AL	27768	AL	Cover, Rear	1
51	76767	FPM	76767	FPM	O-Ring, Rear Cover -70D	1
53	27762	AL	27762	AL	Crankcase w/Guide Pins	1
54	27488	S	27488	S	Pin, Guide	2
64	27784	CM	27784	CM	Pin, Crosshead	3
65	48719	SSHS	48719	SSHS	Rod, Plunger	3
70	76785	FPM	76785	FPM	Seal, Crankcase Oil -70D	3
75	110669	S	110669	S	Slinger, Barrier	3
88	110670	S	110670	S	Washer, Keyhole	3
90	45749	CC	45749	CC	Plunger (M32x93)	3
95	† 89835	SS	† 89835	SS	Stud, Retainer (M7x87)	3
96	20184	PTFE	20184	PTFE	Back-up-Ring, Plunger Retainer	3
97	14161	FPM	14161	FPM	O-Ring, Plunger Retainer - 70D	3
98	44069	SS	44069	SS	Gasket, Plunger Retainer	3
99	44068	SS	44068	SS	Retainer, Plunger [7/02]	3
100	76116	AL	76116	AL	Retainer, LPS	3
106	76298	ST2	76298	ST2	Seal, LPS w/SS-Spg	3
110	<b>49265</b>	<b>CFBB</b>	<b>48583</b>	<b>SS</b>	Manifold, Inlet	1
116	<b>126570</b>	<b>STCP R</b>	<b>19085</b>	<b>S</b>	Lockwasher	4
117	<b>126518</b>	<b>STCP R</b>	<b>88398</b>	<b>S</b>	Screw, HSH (M12x40)	4
125	76832	ST4	76832	ST4	Seal, HPS w/S	3
143	11731	FPM	11731	FPM	O-Ring, Adapter, LPS, Rear	3
150	<b>45752</b>	<b>BB</b>	<b>45835</b>	<b>SS</b>	Adapter, LPS	3
154	11744	FPM	11744	FPM	O-Ring, Adapter, LPS, Front	3
155	11745	FPM	11745	FPM	O-Ring, Adapter, Valve -70D	6
157	<b>45751</b>	<b>BB</b>	<b>45834</b>	<b>SS</b>	Adapter, Valve	3
164	† 46857	SS	† 46857	SS	Seat [11/95] (See Tech Bulletin 076)	6
165	48238	FPM	48238	FPM	O-Ring, Seat	6
166	† 45839	SS	† 45839	SS	Valve	6
167	† 45840	SS	† 45840	SS	Spring	6
168	110682	PVDF	110682	PVDF	Retainer, Spring	6
185	<b>49267</b>	<b>CFBB</b>	<b>48585</b>	<b>SS</b>	Manifold, Discharge	1
186	<b>126570</b>	<b>STCP R</b>	<b>19085</b>	<b>S</b>	Lockwasher	8
188	<b>126517</b>	<b>STCP R</b>	<b>89628</b>	<b>S</b>	Screw, HSH (M12x65)	8

Optional Parts And Accessories On Page 4

**Bold print part numbers are unique to a particular pump model.** [ ] Date of latest production change.

†Production parts different from service parts. R Components comply with RoHS Directive.

\*Review individual parts in each kit for material code identification.

View Tech Bulletins 002, 003, 024, 036, 043, 053, 074, 076, 081, 083, 085 and 095 for additional information.

MATERIAL CODES (Not Part of Part Number): AL=Aluminum BB=Brass CC=Ceramic CFBB=Chrome Forged Brass CM=Chrome-moly

FCM=Forged Chrome-moly FPM=Fluorocarbon HT=High Temp (EPDM Alternative) NBR=Medium Nitrile (Buna-N) NY=Nylon

PTFE=Pure Polytetrafluoroethylene PVDF=Polyvinylidene Fluoride S=304SS SS=316S SSSL=Steel

SSHS=316SS/High Strength STCP=Steel/Chrome Plated

TNM=Special High Strength

# EXPLODED VIEW

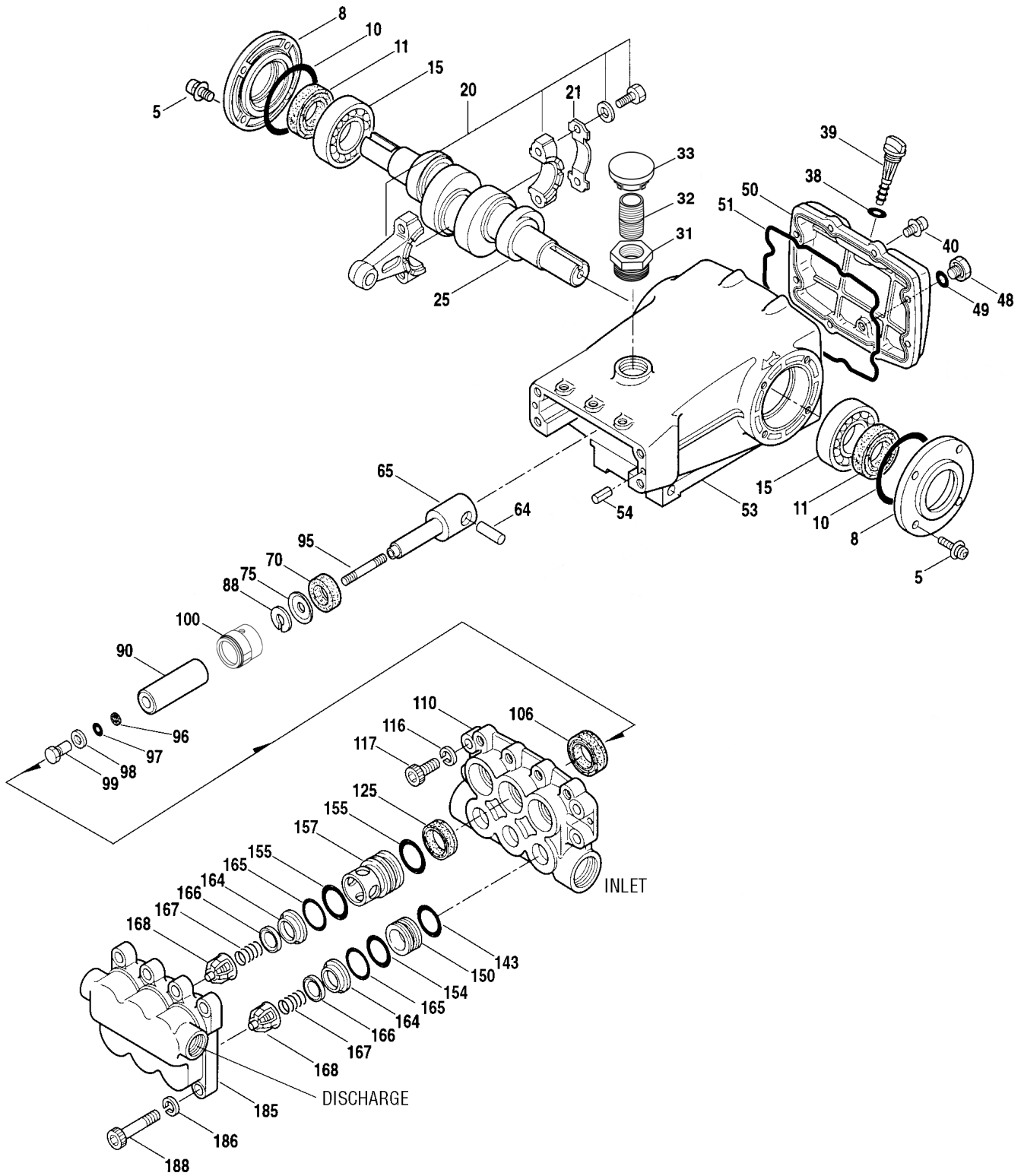

Models  
Standard - 2530.44101  
Stainless Steel - 2531.44101  
November 2011

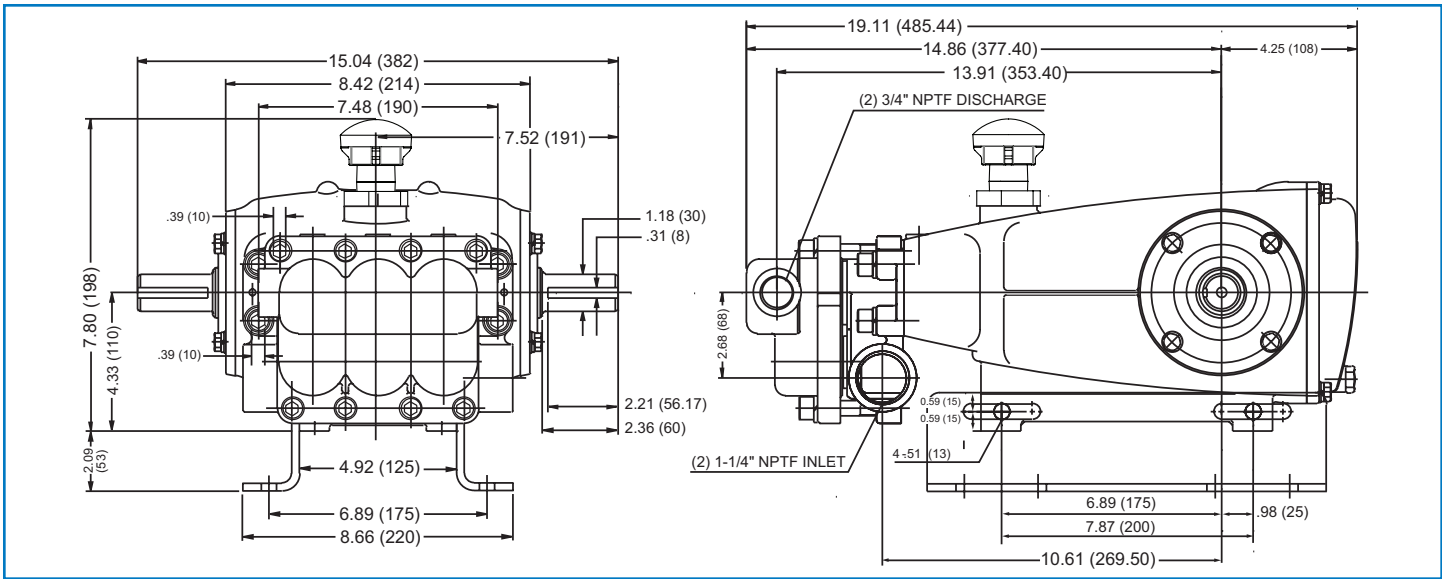

Models 2530.44101, 2531.44101

## OPTIONAL PARTS AND ACCESSORIES

Part Number	Description	QTY
7022/ 7022.100	Regulator (Primary Pressure Control)	1
7590.0110	Unloader (Primary Pressure Control)	1
7590.1110/ 890702	Relief Valve (Secondary Pressure Control)	1
7590.1110/ 890713	Pop-Off Valve (Secondary Pressure Control)	1
6073	Pressure Gauge	1
6013	Accumulator	1
30614	Mounting Rails	1
26516	Shaft Protector	1
990036	Key (M8x7x40)	1
76144	Kit, Oil Indicator (3/8" x 24") See Individual Data Sheet	1
34334	Kit, Oil Drain (3/8" x 24") See Individual Data Sheet	1
76087	Kit, Seal (Includes Items 97, 106, 125, 143, 154, and 155)	1
31267	Kit, Valve (Includes Items 143, 154, 155, 164, 165, 166, 167, and 168)	2
814838.44101/ 816735.44101	Complete Head	1
30696	Pliers (Reverse)	1
6107	Oil, Bottle (21 oz.) ISO 68 Hydraulic	4
6119	Lubricant, Antiseize (1 oz.)	1

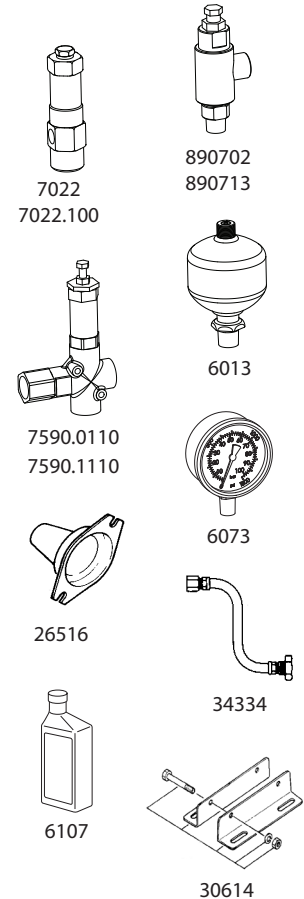

**Demand Genuine Cat Pump Parts And Accessories.**



**CAT PUMPS**  
 1681 - 94TH LANE N.E. MINNEAPOLIS, MN 55449-4324  
 PHONE (763) 780-5440 — FAX (763) 780-2958  
 e-mail: techsupport@catpumps.com  
 www.catpumps.com