

Plunger Pumps

FEATURING

MANIFOLD: High strength forged brass or nickel plated for long term use.

BOLTS: Eight 10mm grade 8.8.

PLUNGERS: A special thick solid ceramic for long life, strong durability and more resilience.

CRANKCASE: Precision die-cast, large cooling fins and anodized for maximum heat dissipation. Bayonet style sight glass located in the rear and side cover, fill and side and bottom drain plugs.

BEARINGS: Oversized premium tapered roller bearing for maximum life and load distribution.

BEARINGS SUPPORTS: Precision die-cast and machined to assure concentricity and alignment.

VALVES, SEATS, AND SPRINGS: Stainless steel with specially designed Ultra Form cages to provide long life and positive seating.

SEALS AND U-PACKINGS: Continuously lubricating for extended life. Triple lip oil seal for assured crankcase seal.

PLUNGER RODS: High strength stainless steel, for heavy duty use.

CONNECTING RODS: Two-piece special alloy aluminum based material, oversized for maximum strength, load disbursement, and long life. Heavy pin area construction, for added load strength.

DIMENSIONS



XWLA N version Solid shaft pump ø 24 mm

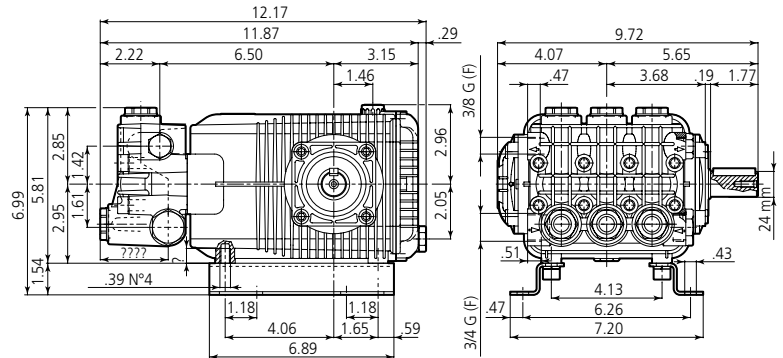

SPECIFICATIONS

MODEL	MAX GPM	MAX LMP	MAX PSI	MAX BAR	POWER EBHP	BORE DIA MM	STROKE MM	CRANKSHAFT ID STAMP	WEIGHT LBS.
XWLA13G15N	13.0	49.2	1450	100	13.0	28	17.2	2	34

Oil Capacity = 32oz

Maximum Fluid Temperature = 140° F

Inlet Thread = 3/4" F

Discharge Thread = 3/8" F

Torque Specifications Inch pounds (ft. lbs)

HEAD	PISTON NUT	REAR COVER	SIDE COVER	VALVE CAP	CON RODS
442 (37)	106 (8.8)	92 (7.7)	217 (18)	602 (50)	89 (7.5)

SPECIAL NOTE: Use AR64516 Oil. First change oil after 50 hours of use. Then every 500 hours. This oil is specially formulated to provide correct lubrication properties for our pumps. **No** other oil is factory approved for these pumps. **ANNONI REVERBERI** High Performance Pumps



PARTS BREAKDOWN

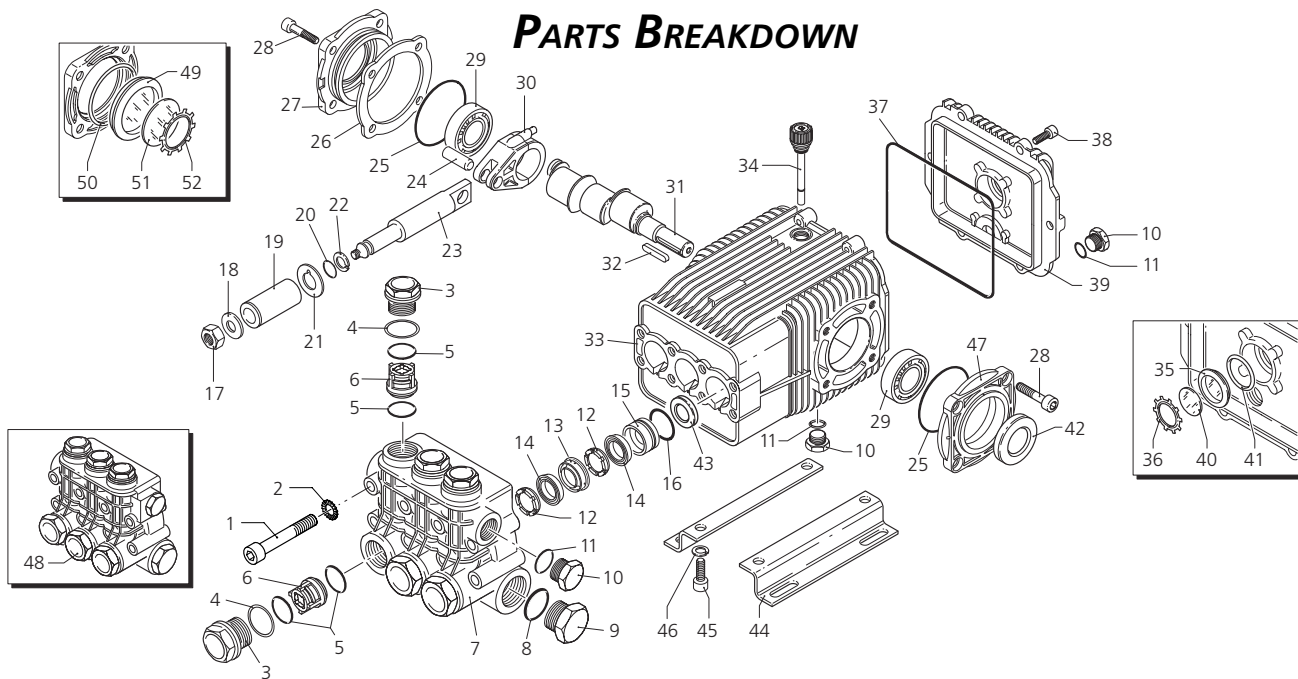

Pos.	Code	Description	Qty.	Pos.	Code	Description	Qty.
1	1940260	Screw	8	40	1780690	Disc	1
2	650530	Washer	8	41	1140450	O-Ring	1
3	1940140	Plug	6	42	820680	Seal	1
4	1940150	Ring	6	43	1940560	Seal	3
5	1140450	O-Ring	12	44	1940370	Base	2
6	1949050	Complete valve	6	45	1940380	Screw	4
7	1941550	Pump head	1	46	200231	Washer	4
8	550350	O-Ring	1	47	1941240	Open bearing support	1
9	1140300	Plug 3/4" G	1	48	1949205	Pump head assem Ø28	1
10	1980740	Plug 3/8" G	3	49	1941270	Oil indicator	1
11	740290	O-Ring	3	50	100410	O-Ring	1
12	1941570	Support ring Ø28	6	51	1941260	Disc	1
13	1140280	Front piston guide Ø28	3	52	1941290	Snap ring	1
14	820630	Gasket Ø28	6				
15	1941560	Rear piston guide Ø28	3				
16	1140490	O-Ring	3				
17	1940570	Nut	3				
18	1940580	Washer	3				
19	1140190	Piston Ø28	3				
20	880840	O-Ring	3				
21	1140160	Spacer Ø28	3				
22	1940120	Ring	3				
23	1940070	Guiding piston	3				
24	1940060	Piston pin	3				
25	1941380	O-Ring	3				
26	1941390	0,05 mm shim	1-3				
27	1941400	0,10 mm shim	1-3				
28	1941410	0,19 mm shim	1-3				
29	1941420	0,25 mm shim	1-3				
30	1949011	Complete side cover	1				
31	850370	Screw	8				
32	1140410	Bearing	2				
33	1940050	Con rod	3				
34	1940170	Crankshaft	1				
35	620250	Key	1				
36	1941330	Pump housing	1				
37	1140370	Oil cap	1				
38	1260250	Oil indicator	1				
39	1260430	Snap ring	1				
	1940410	O-Ring	1				
	1200430	Screw	6				
	1949010	Complete cover	1				

26

Legend

Ø 28
XWLA13G15

Repair Kits

Water Seal Kit 1853		Valve Kit 2780		Pistons Kit 1849		Oil Seals Kit 1853	
Pos.	Qty.	Pos.	Qty.	Pos.	Qty.	Pos.	Qty.
12	3	5	6	19	3	25	2
14	3	6	6			37	1
16	3					42	1
						43	1

Piston Guide Kit 2507

Pos.	Qty.
13	3
15	3

Special Parts

Code	Description	Qty.
2036	Viton water seals Ø28	1

