

Plunger Pumps

FEATURING

MANIFOLD: High strength forged brass or nickel plated for long term use.

BOLTS: Eight 10mm grade 8.8.

PLUNGERS: A special ultra thick solid ceramic for long life, strong durability and more resilience retaining bolts.

CRANKCASE: Precision die-cast, large cooling fins and anodized for maximum heat dissipation. Bayonet style sight glass located in the rear and side cover, fill and side and bottom drain plugs.

BEARINGS: Oversized premium SKF tapered roller bearing for maximum life and load disbursement.

BEARINGS SUPPORTS: Precision die-cast and machined to assure concentricity and alignment.

VALVES, SEATS, AND SPRINGS: Stainless steel with specially designed Ultra Form cages to provide long life and positive seating. O-Ring and back-up ring provide longer life and better performance at high pressure.

SEALS AND U-PACKINGS: Continuously lubricating for extended life. Triple lip oil seal for assured crankcase seal.

PLUNGER RODS: High strength stainless steel, for heavy duty use.

CONNECTING RODS: Two-piece special alloy aluminum based material, oversized for maximum strength, load disbursement, and long life. Heavy pin area construction, for added load strength.

DIMENSIONS



SXW N version Solid shaft pump ø 24 mm

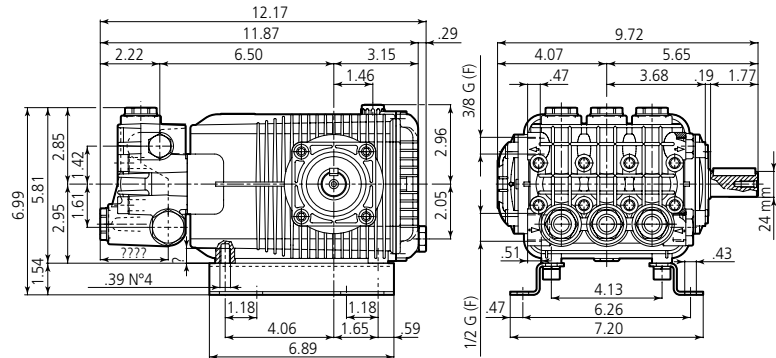

SPECIFICATIONS

MODEL	MAX GPM	MAX LMP	MAX PSI	MAX BAR	POWER EBHP	BORE DIA MM	STROKE MM	CRANKSHAFT ID STAMP	WEIGHT LBS.
SXW15.35	3.96	15	5100	350	15	18	15.0	8	35
SXW21.35	5.55	21	5100	350	20	18	21.0	7	35

Oil Capacity = 32oz

Maximum Fluid Temperature = 140° F

Inlet Thread = 1/2" F

Discharge Thread = 3/8" F

Torque Specifications Inch pounds (ft. lbs)

HEAD	PISTON NUT	REAR COVER	SIDE COVER	VALVE CAP	CON RODS
442 (37)	62 (5.2)	92 (7.7)	217 (18)	531 (44)	89 (7.5)

SPECIAL NOTE: Use AR64516 Oil. First change oil after 50 hours of use. Then every 500 hours. This oil is specially formulated to provide correct lubrication properties for our pumps. **No** other oil is factory approved for these pumps.



PARTS BREAKDOWN

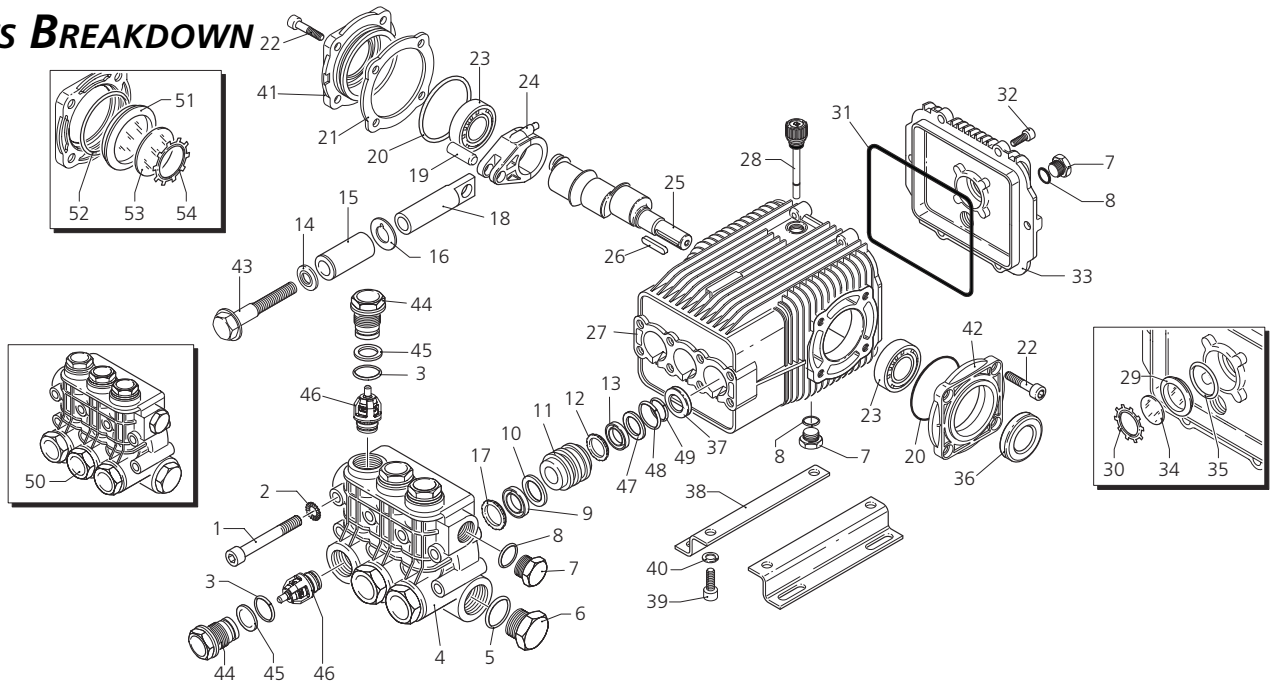

Pos.	Code	Description	Qty.	Pos.	Code	Description	Qty.	Legend			
1	1940260	Screw	8	39	1940380	Screw	4	Ø 18 Ø 18 For ○ For □ SXW15.35 SXW21.35			
2	650530	Washer	8	40	200231	Washer	4				
3	880830	O-Ring	6	41	1949011	Complete side cover	1	Repair Kits			
4	1940930	Pump head	1	42	1941240	Open bearing support	1				
5	180101	O-Ring	1	43	1940920	Piston fixing screw	3	Water Seal	Valve	Pistons	Oil Seals
6	820361	Plug 1/2" G	1	44	1940940	Plug	6	Kit 2874	Kit 2871	Kit 2548	Kit 2873
7	1980740	Plug 3/8" G	3	45	1941070	Ring	6	Pos. Qty.	Pos. Qty.	Pos. Qty.	Pos. Qty.
8	740290	O-Ring	3	46	1949051	Complete valve	6	9 3	46 6	14 3	20 2
9	1941200	Plug	3	47	1941030	Spacer	3	10 3		15 3	31 1
10	1941050	Ring	3	48	820490	O-Ring	3	17 3		16 3	36 1
11	1940950	Piston guide	3	49	1941010	Snap ring	3				37 1
12	1941350	Support ring	3	50	1949204	Pump head assembly	1	Piston Guide Kit 2875 Pos. Qty. 11 3 12 3 13 3			
13	1941340	Gasket	3	51	1941270	Oil indicator	1				
14	1340600	Washer	3	52	100410	O-Ring	1				
15	1941020	Piston	3	53	1941260	Disc	1				
16	1383190	Spacer	3	54	1941290	Snap ring	1				
17	1941190	Support ring	3								
18	1940960	Guiding piston	3								
19	1940060	O-Ring	3								
20	1941380	O-Ring	2								
21	1941390	0,05 mm shim	1								
22	850370	Screw	8								
23	1140410	Bearing	2								
24	1940050	Con rod	3								
25	1940980	Crankshaft	○ 1								
	1940970	Crankshaft	□ 1								
26	650250	Key	1								
27	1941330	Pump housing	1								
28	1140370	Plug	1								
29	1260250	Oil indicator	1								
30	1260430	Snap ring	1								
31	1940410	O-Ring	1								
32	1200430	Screw	6								
33	1949010	Complete cover	1								
34	1780690	Disc	1								
35	1140450	O-Ring	1								
36	820680	Seal	1								
37	1940560	Seal	3								
38	1940370	Base	2								

