

Plunger Pumps

FEATURING

MANIFOLD: High strength forged brass or nickel plated for long term use.

BOLTS: Eight 8mm grade 8.8.

PLUNGERS: A special thick solid ceramic for long life, strong durability and more resilience.

CRANKCASE: Precision die-cast, large cooling fins and anodized for maximum heat dissipation. Sight glass, fill and side and bottom drain plugs.

BEARINGS: Oversized tapered roller bearing for maximum life and load distribution.

BEARINGS SUPPORTS: Precision die-cast and machined to assure concentricity and alignment.

VALVES, SEATS, AND SPRINGS: Stainless steel with specially designed Ultra Form cages to provide long life and positive seating.

SEALS AND V-PACKINGS: Continuously lubricating for extended life.

PLUNGER RODS: Stainless steel construction for strength, no plating to scrape off, back-up and o-ring plunger sealing system.

CONNECTING RODS: One piece special alloy aluminum or bronze for higher pressure, oversized for maximum strength, load disbursement, and long life. Heavy pin area construction, for added load strength.

DIMENSIONS



RKA N version Solid shaft pump / ø 24 mm

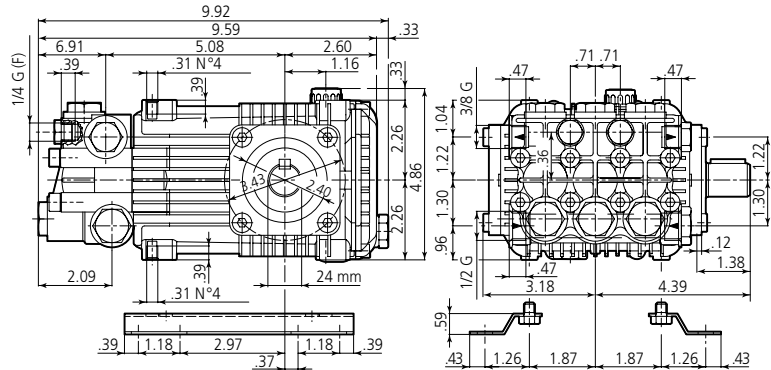

SPECIFICATIONS

MODEL	MAX GPM	MAX LMP	MAX PSI	MAX BAR	POWER EBHP	BORE DIA MM	STROKE MM	CRANKSHAFT ID STAMP	WEIGHT LBS.
RKA3.5G25N	3.5	13.2	2500	170	5.0	18	10.8	5	19
RKA3.5G30N	3.5	13.2	3000	205	7.5	18	10.8	5	19
RKA3.5G40HN	3.5	13.2	4000	275	10.0	18	10.8	5	20
RKA4G20N	4.0	15.1	2000	140	5.0	18	12.0	4	19
RKA4G30N	4.0	15.1	3000	205	7.5	18	12.0	4	19
RKA4G30HN	4.0	15.1	3000	205	7.5	18	12.0	4	19
RKA4G35N	4.0	15.1	3500	241	10.0	18	12.0	4	20
RKA4G40HN	4.0	15.1	4000	275	11.0	18	12.0	4	19
RKA4.5G17N	4.5	17.0	1700	115	5.0	18	13.8	2	19
RKA4.5G25HN	4.5	17.0	2500	170	7.5	18	13.8	2	20
RKA4.5G35HN	4.5	17.0	3500	241	11.0	18	13.8	2	19
RKA5.5G13N	5.5	20.8	1300	90	5.0	20	13.8	2	19
RKA5.5G20HN	5.5	20.8	2000	138	7.5	20	13.8	2	20
RKA5.5G30HN	5.5	20.8	3000	205	11.0	20	13.8	2	20
RKA6.5G20HN	6.6	25.0	2000	138	9.0	22	13.8	2	20
RKA4G20HN	7.1	27.0	2000	138	10.0	22	14.6	1	20

Oil Capacity = 15.3 oz

Maximum Fluid Temperature = 140° F

Inlet Thread = 1/2" F

Discharge Thread = 3/8" F

Torque Specifications Inch pounds (ft. lbs)

HEAD	PISTON NUT	REAR COVER	SIDE COVER	VALVE CAP	CON RODS
217 (18)	106 (8.8)	89 (7.5)	217 (18)	478 (40)	N/A

SPECIAL NOTE: Use AR64516 Oil. First change oil after 50 hours of use. Then every 500 hours. This oil is specially formulated to provide correct lubrication properties for our pumps. **No** other oil is factory approved for these pumps.



PARTS BREAKDOWN

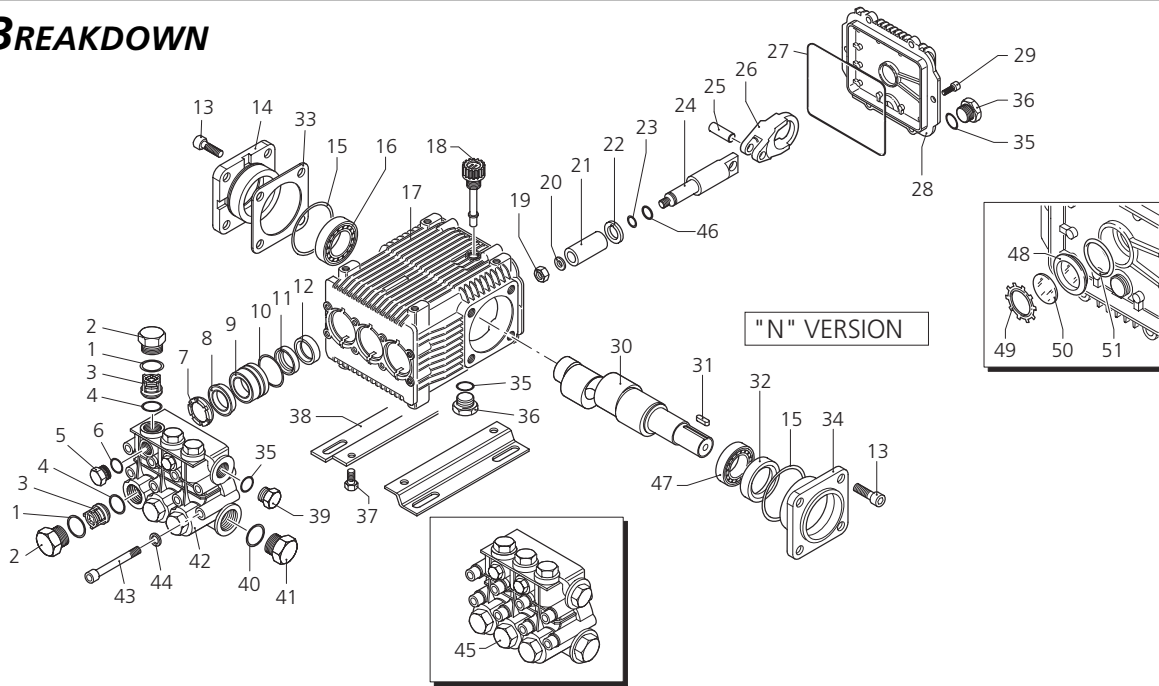

Pos.	Code	Description	Qty.	Pos.	Code	Description	Qty.	Legend				
1	960160	O-Ring	6	29	1343510	Screw	6	Ø 18	Ø 18	Ø 20	Ø 22	
2	960090	Plug RK	6	30	2280100	Crankshaft	1	For ○	For □	For ▼	For ◆	
	960850	Plug RKH*	6		2280090	Crankshaft	1	RKA3.5G22	RKA4G20	RKA5.5G13	RKA6.5G13	
	1380740	Plug RKH	6		2280070	Crankshaft	1	RKA3.5G25	RKA4G30A	RKA5.5G20H	RKA6.5G20H	
3	1389051	Complete valve	6		2280060	Crankshaft	1	RKA3.5G30	RKA4G30	RKA5.5G26H		
4	880830	O-Ring	6	31	1380520	Key	1	RKA3.5G30H	RKA4G30H	RKA5.5G30H		
5	880581	Plug 1/4" G RK	2	32	180340	Seal	1	RKA3.5G40H*	RKA4G35			
6	1380690	Plug 1/4" G Nickel RKH-H*	2	33	1380120	0,10 mm shim	1-3		RKA4G36H*		For ■	
	820510	O-Ring	2		1380130	0,20 mm shim	1-3	For ●	RKA4G40H*		RKA7G13	
	960110	Support ring Ø18	3		1380530	0,25 mm shim	1-3	RKA4.5G17			RKAG20H	
	840300	Support ring Ø20	3	34	1382810	0,05 mm shim	1-3	RKA4.5G25H				
	840320	Support ring Ø22	3	35	1380040	Open bearing sup.	1	RKA4.5G30H				
	880320	Gasket Ø18	3	36	740290	O-Ring	3	RKA4.5G35H				
	840290	Gasket Ø20	3	37	1980740	Plug 3/8" G	2	RKA4.5G40H				
	840330	Gasket Ø22	3	38	1260470	Screw	4				*over 3600 psi	
	1380090	Piston guide Ø18	3	39	1380141	Base	2					
	1380150	Piston guide Ø20	3	40	1980740	Plug 3/8" G RK	1	Water Seal	Valve	Pistons	Oil Seals	
	1380160	Piston guide Ø22	3	41	1981180	Plug 3/8" G Nickel RKH-H*	1	Kit 1857 Ø18		Kit 2546 Ø18		
10	961240	O-Ring	3	42	180101	O-Ring	1	Kit 1887 Ø20		Kit 2547 Ø20		
	880330	Gasket Ø18	3		820361	Plug 1/2" G RK	1	Kit 1888 Ø22	Kit 2864	Kit 2759 Ø22	Kit 1855	
	840280	Gasket Ø20	3		960870	Plug 1/2" G Nickel RKH-H*	1	Pos. Qty.	Pos. Qty.	Pos. Qty.	Pos. Qty.	
	840340	Gasket Ø22	3		1381071	Pump head Ø18 RK	1	8 3	3 6	19 3	12 3	
12	1383130	Seal	3		1381070	Pump head Ø18 RKH-H*	1	10 3	4 6	20 3	15 2	
13	850370	Screw	4		1380020	Pump head Ø20 RK	1	11 3		21 3	27 1	
14	1380050	Bearing support	1		1380680	Pump head Ø20 RKH	1	Support Rings		22 3	32 1	
15	640030	O-Ring	1		1383010	Pump head Ø22 RK	1	Kit 1829 Ø18		23 3		
16	2280240	Bearing	1		1383310	Pump head Ø22 RKH	1	Kit 1815 Ø20		46 3		
17	1382770	Pump housing	1		43	820150	Screw	8	Kit 1816 Ø22			
18	880130	Oil cap	3		44	1381850	Washer	8	Pos. Qty.			
19	962010	Nut	3		1389270	Pump head assem Ø18 RK	1	7 3				
20	962000	Washer	3		1389272	Pump head assem Ø18 RKH	1					
21	1380940	Ceramic piston Ø18	3		1389271	Pump head assem Ø18 RKH*	1					
	1380930	Ceramic piston Ø20	3		1389208	Pump head assem Ø20 RK	1					
	1382360	Ceramic piston Ø22	3		1389212	Pump head assem Ø20 RKH	1					
22	1380950	Spacer	3		1389268	Pump head assem Ø22 RK	1					
23	600180	O-Ring	3		1389269	Pump head assem Ø22 RKH	1					
24	1380920	Guiding piston	3		46	1080401	Ring	3				
25	1380060	Piston pin	3		47	840370	Bearing	1				
26	1383050	Aluminum con rod	3		48	1260250	Oil indicator	1				
	1383020	Bronze con rod	3		49	1260430	Snap ring	1				
27	1780510	O-Ring	1		50	1780690	Disc	1				
28	1789010	Complete cover	1		51	1140450	O-Ring	1				



Plunger Pumps

FEATURING

MANIFOLD: High strength forged brass or nickel plated for long term use.

BOLTS: Eight 8mm grade 8.8.

PLUNGERS: A special thick solid ceramic for long life, strong durability and more resilience.

CRANKCASE: Precision die-cast, large cooling fins and anodized for maximum heat dissipation. Sight glass, fill and side and bottom drain plugs.

BEARINGS: Oversized tapered roller bearing for maximum life and load distribution.

BEARINGS SUPPORTS: Precision die-cast and machined to assure concentricity and alignment.

VALVES, SEATS, AND SPRINGS: Stainless steel with specially designed Ultra Form cages to provide long life and positive seating.

SEALS AND V-PACKINGS: Continuously lubricating for extended life.

PLUNGER RODS: Stainless steel construction for strength, no plating to scrape off, back-up and o-ring plunger sealing system.

CONNECTING RODS: One piece special alloy aluminum or bronze for higher pressure, oversized for maximum strength, load disbursement, and long life. Heavy pin area construction, for added load strength.

DIMENSIONS



RKA

E version + F17
Hollow shaft pump \varnothing 1" 1/8

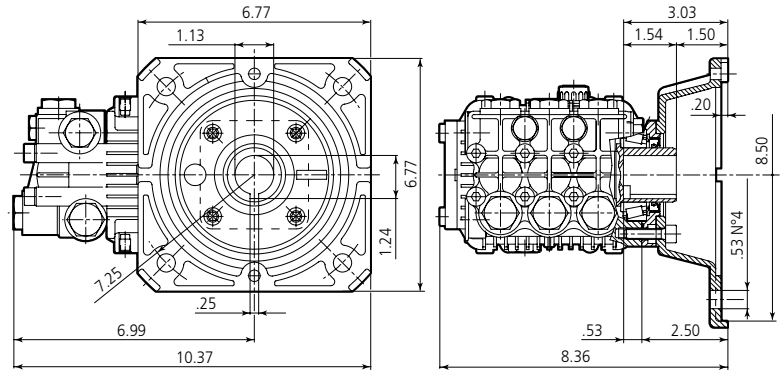

SPECIFICATIONS

MODEL	MAX GPM	MAX LMP	MAX PSI	MAX BAR	POWER EBHP	BORE DIA MM	STROKE MM	CRANKSHAFT ID STAMP	WEIGHT LBS.
RKA3.5G30E-F17	3.5	13.2	3000	205	7.5	18	10.8	5	22
RKA3.5G30HE-F17	3.5	13.2	3000	205	7.5	18	10.8	5	22
RKA3.5G40HE-F17	3.5	13.2	4000	275	9.6	18	10.8	5	22
RKA4G20E-F17	4.0	15.1	2000	140	5.0	18	12.0	4	21
RKA4G30E-F17	4.0	15.1	3000	205	7.5	18	12.0	4	21
RKA4G30HE-F17	4.0	15.1	3000	205	7.5	18	12.0	4	21
RKA5.5G13E-F17	5.5	20.8	1300	90	5.0	20	13.8	2	21
RKA6.5G20HE-F17	6.6	25.0	2000	138	9.0	22	13.8	2	21
RKA7G20HE-F17	7.1	27.0	2000	138	10.0	22	14.6	1	21

Oil Capacity = 15.3 oz

Maximum Fluid Temperature = 140° F

Inlet Thread = 1/2" F

Discharge Thread = 3/8" F

Torque Specifications Inch pounds (ft. lbs)

HEAD	PISTON NUT	REAR COVER	SIDE COVER	VALVE CAP	CON RODS
217 (18)	106 (8.8)	89 (7.5)	217 (18)	478 (40)	N/A

SPECIAL NOTE: Use AR64516 Oil. First change oil after 50 hours of use. Then every 500 hours. This oil is specially formulated to provide correct lubrication properties for our pumps. **No** other oil is factory approved for these pumps.



PARTS BREAKDOWN

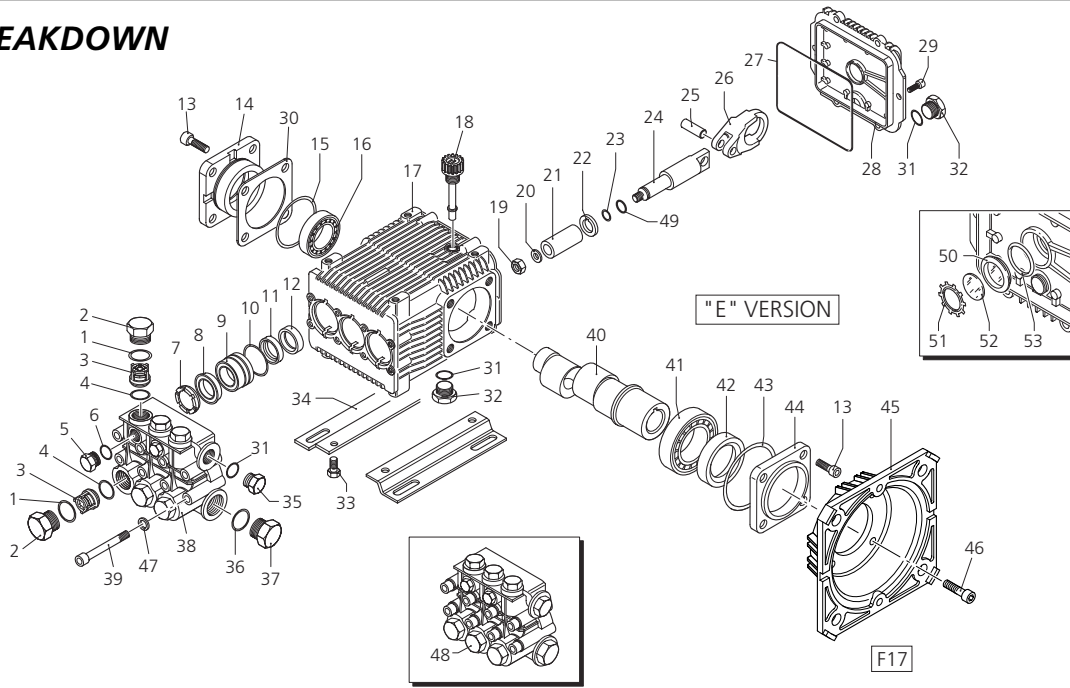

Pos.	Code	Description	Qty.	Pos.	Code	Description	Qty.	Legend			
1	960160	O-Ring	6	30	1380120	0,10 mm shim	1-3	Ø 18	Ø 18	Ø 20	Ø 22
2	960090	Plug RKA	6	31	1380130	0,20 mm shim	1-3	For ○	For □	For ▼	For ◆
3	1380740	Plug RKAH	6	32	1380530	0,25 mm shim	1-3	RKA3.5G25	RKA4G20	RKA5.5G13	RKA6.5G13
4	1389051	Complete valve	6	33	1382810	0,05 mm shim	1-3	RKA3.5G30	RKA4G30		RKA6.5G20H
5	880830	O-Ring	6	34	742090	O-Ring	3	RKA3.5G30H	RKA4G30H		
6	880581	Plug 1/4" G RKA	2	35	1980740	Plug 3/8" G	2	For ●			
7	1380690	Plug 1/4" G Nickel RKAH	2	36	1260470	Screw	4	RKA7G13			
8	820510	O-Ring	2	37	1380141	Base	2	RKA7G20H			
9	960110	Support ring Ø18	3	38	1980740	Plug 3/8" G RKA	1				
10	840300	Support ring Ø20	3	39	1981180	Plug 3/8" G Nickel RKAH	1				
11	840320	Support ring Ø22	3	40	180101	O-Ring	1				
12	880320	Gasket Ø18	3	41	820361	Plug 1/2" G RKA	1				
13	840290	Gasket Ø20	3	42	960870	Plug 1/2" G Nickel RKAH	1				
14	840330	Gasket Ø22	3	43	1381071	Pump head Ø18 RKA	1	Water Seal Kit 1857 Ø18	Valve Kit 2864	Pistons Kit 2546 Ø18	Oil Seals Kit 1856
15	1380090	Piston guide Ø18	3	44	1381070	Pump head Ø18 RKAH	1	Kit 1887 Ø20	Pos. Qty.	Pos. Qty.	Pos. Qty.
16	1380150	Piston guide Ø20	3	45	1380020	Pump head Ø20 RKA	1	Kit 1888 Ø22	8 3	19 3	12 3
17	1380160	Piston guide Ø22	3	46	1383010	Pump head Ø22 RKA	1	Pos. Qty.	10 3	20 3	15 2
18	961240	O-Ring	3	47	1383310	Pump head Ø22 RKAH	1	11 3	4 6	21 3	27 1
19	880330	Gasket Ø18	3	48	820150	Screw	8	Support Rings Kit 1829 Ø18	22 3	22 3	42 1
20	840280	Gasket Ø20	3	49	2280260	Hollow shaft	1	Kit 1815 Ø20	23 3	23 3	43 1
21	840340	Gasket Ø22	3	50	2280200	Hollow shaft	1	Kit 1816 Ø22	49 3		
22	1383130	Seal	3	51	2280270	Hollow shaft	1	Pos. Qty.	7 3		
23	850370	Screw	4	52	2280280	Hollow shaft	1				
24	1380050	Bearing support	1	53	1380320	Bearing	1				
25	640030	O-Ring	1		42	621170	Seal	1			
26	2280240	Bearing	1		43	1380220	O-Ring	1			
27	1382770	Pump housing	1		44	1380210	Shaft cover	1			
28	880130	Oil cap	3		45	1380360	Electric motor flange	1			
29	962010	Nut	3		46	620610	Screw	4			
	962000	Washer	3		47	1381850	Washer	8			
	1380940	Ceramic piston Ø18	3		48	1389270	Pump head assem Ø18 RKA	1			
	1380930	Ceramic piston Ø20	3		49	1389272	Pump head assem Ø18 RKAH	1			
	1382360	Ceramic piston Ø22	3		50	1389208	Pump head assem Ø20 RKA	1			
	1380950	Spacer	3		51	1389268	Pump head assem Ø22 RKA	1			
	600180	O-Ring	3		52	1389269	Pump head assem Ø22 RKAH	1			
	1380920	Guiding piston	3		53	1080401	Ring	1			
	1380060	Piston pin	3			50	1260250	Oil indicator	1		
	1383050	Aluminum con rod	3			51	1260430	Snap ring	1		
	1383020	Bronze con rod	3			52	1780690	Disc	1		
	1780510	O-Ring	1			53	1140450	O-Ring	1		
	1789010	Complete cover	1								
	1343510	Screw	6								

