

# Series

# P54W, P58W & P59W

---

Triplex Ceramic  
Plunger Pump  
Operating Instructions/  
Repair and Service  
Manual



---

**GIANT**

### Contents:

Installation Instructions:	page 2
Pump Specifications:	pages 3-5
Exploded View:	page 6
Parts List:	page 7
Kits/ Torque Specs.:	page 8
Trouble Shooting:	page 9
Repair Instructions:	pages 10-11
Dimensions:	back page
Warranty Information:	back page

# INSTALLATION INSTRUCTIONS

Installation of the Giant Industries, Inc., pump is not a complicated procedure, but there are some basic steps common to all pumps. The following information is to be considered as a general outline for installation. If you have unique requirements, please contact Giant Industries, Inc. or your local distributor for assistance.

1. The pump should be installed flat on a base to a maximum of a 15 degree angle of inclination to ensure optimum lubrication.
2. The inlet to the pump should be sized for the flow rate of the pump with no unnecessary restrictions that can cause cavitation. Teflon tape should be used to seal all joints. If pumps are to be operated at temperatures in excess of 160° F, it is important to insure a positive head to the pump to prevent cavitation.
3. The discharge plumbing from the pump should be properly sized to the flow rate to prevent line pressure loss to the work area. It is essential to provide a safety bypass valve between the pump and the work area to protect the pump from pressure spikes in the event of a blockage or the use of a shut-off gun.
4. Use of a dampener is necessary to minimize pulsation at drive elements, plumbing, connections, and other system areas. The use of a dampener with Giant Industries, Inc. pumps is optional, although recommended by Giant Industries, Inc. to further reduce system pulsation. Dampeners can also reduce the severity of pressure spikes that occur in systems using a shut-off gun. A dampener must be positioned downstream from the unloader.
5. Crankshaft rotation on Giant Industries, Inc. pumps should be made in the direction designated by the arrows on the pump crankcase. Reverse rotation may be safely achieved by following a few guidelines available upon request from Giant Industries, Inc. Required horsepower for system operation can be obtained from the charts on pages 3-5.
6. Before beginning operation of your pumping system, remember: Check that the crankcase and seal areas have been properly lubricated per recommended schedules. Do not run the pump dry for extended periods of time. Cavitation will result in severe damage. Always remember to check that all plumbing valves are open and that pumped media can flow freely to the inlet of the pump.

Finally, remember that high pressure operation in a pump system has many advantages. But, if it is used carelessly and without regard to its potential hazard, it can cause serious injury.

## IMPORTANT OPERATING CONDITIONS

**Failure to comply with any of these conditions invalidates the warranty.**

1. Prior to initial operation, add oil to the crankcase so that oil level is between the two lines on the oil dipstick. **DO NOT OVERFILL.**  
**Giant Industries, Inc. oil or the equivalent Kendall Turbo GT1 oil may be used.**  
Crankcase oil should be changed after the first 50 hours of operation, then at regular intervals of 500 hours or less depending on operating conditions.
2. Pump operation must not exceed rated pressure, volume, or RPM. A pressure relief device must be installed in the discharge of the system.
3. Acids, alkalines, or abrasive fluids cannot be pumped unless approval in writing is obtained before operation from Giant Industries, Inc.
4. Run the pump dry approximately 10 seconds to drain the water before exposure to freezing temperatures.

# Specifications Model P54W

Volume .....	Up to 4.5 GPM
Discharge Pressure .....	Up to 4000 PSI
Inlet Pressure .....	Up to 90 PSI
Speed .....	Up to 1635 RPM
Plunger Diameter .....	16mm
Stroke .....	18.1mm
Crankcase Oil Capacity .....	14 fl.oz.
Temperature of Pumped Fluids .....	Up to 160° F
Inlet Ports .....	(2) 3/8" BSP & (1) 1/2" BSP
Discharge Ports .....	(2) 3/8" BSP
Crankshaft Mounting .....	Either Side
Shaft Rotation .....	Top of Pulley Towards Fluid End
Weight .....	18 lbs.
Crankshaft Diameter .....	24mm
Volumetric Efficiency @ 1635 .....	0.96
Mechanical Efficiency @ 1635 .....	0.80

Consult the factory for special requirements that must be met if the pump is to operate beyond one or more of the limits specified above.

### PULLEY INFORMATION

Pulley selection and pump speed are based on a 1725 RPM motor and "B" section belts. When selecting desired GPM, allow for a ±5% tolerance on pumps output due to variations in pulleys, belts and motors among manufacturers.

1. Select GPM required, then select appropriate motor and pump pulley from the same line.
2. The desired pressure is achieved by selecting the correct nozzle size that corresponds with the pump GPM.

### HORSEPOWER INFORMATION

Horsepower ratings shown are the power requirements for the pump. Gas engine power outputs must be approximately twice the pump power requirements shown above.

We recommend that a 1.1 service factor be specified when selecting an electric motor as the power source. To compute specific pump horsepower requirements, use the following formula:

$$HP = (GPM \times PSI) / 1460$$

<b>P54W PULLEY SELECTION &amp; HORSEPOWER REQUIREMENTS</b>							
<b>PUMP PULLEY</b>	<b>MOTOR PULLEY</b>	<b>RPM</b>	<b>GPM</b>	<b>2000 PSI</b>	<b>3000 PSI</b>	<b>3500 PSI</b>	<b>4000 PSI</b>
7.75"	4.25"	910	2.5	3.4	5.1	6.0	6.9
7.75"	4.75"	1025	2.8	3.9	5.8	6.8	7.7
7.75"	5.45"	1190	3.3	4.5	6.7	7.8	9.0
7.75"	5.95"	1305	3.6	4.9	7.4	8.6	9.8
7.75"	6.75"	1490	4.1	5.6	8.4	9.8	11.2
7.75"	7.35"	1635	4.5	6.2	9.2	10.8	12.3

# Specifications Model P58W

Volume .....	Up to 5.5 GPM
Discharge Pressure .....	Up to 3500 PSI
Inlet Pressure .....	Up to 90 PSI
Speed .....	Up to 1600 RPM
Plunger Diameter .....	18mm
Stroke .....	18.1mm
Crankcase Oil Capacity .....	14 fl.oz.
Temperature of Pumped Fluids .....	Up to 160°F
Inlet Ports .....	(2) 3/8" BSP & (1) 1/2" BSP
Discharge Ports .....	(2) 3/8" BSP
Crankshaft Mounting .....	Either Side
Shaft Rotation .....	Top of Pulley Towards Fluid End
Weight .....	18 lbs.
Crankshaft Diameter .....	24mm
Volumetric Efficiency @ 1600 .....	0.94
Mechanical Efficiency @ 1600 .....	0.84

Consult the factory for special requirements that must be met if the pump is to operate beyond one or more of the limits specified above.

### PULLEY INFORMATION

Pulley selection and pump speed are based on a 1725 RPM motor and "B" section belts. When selecting desired GPM, allow for a ±5% tolerance on pumps output due to variations in pulleys, belts and motors among manufacturers.

1. Select GPM required, then select appropriate motor and pump pulley from the same line.
2. The desired pressure is achieved by selecting the correct nozzle size that corresponds with the pump GPM.

### HORSEPOWER INFORMATION

Horsepower ratings shown are the power requirements for the pump. Gas engine power outputs must be approximately twice the pump power requirements shown above.

We recommend that a 1.1 service factor be specified when selecting an electric motor as the power source. To compute specific pump horsepower requirements, use the following formula:

$$HP = (GPM \times PSI) / 1460$$

<b>P58W PULLEY SELECTION &amp; HORSEPOWER REQUIREMENTS</b>							
<b>PUMP PULLEY</b>	<b>MOTOR PULLEY</b>	<b>RPM</b>	<b>GPM</b>	<b>2000 PSI</b>	<b>2500 PSI</b>	<b>3000 PSI</b>	<b>3500 PSI</b>
7.75"	4.25"	910	3.1	4.2	5.3	6.4	7.4
7.75"	4.75"	1025	3.5	4.8	6.0	7.2	8.4
7.75"	5.45"	1190	4.1	5.6	6.9	8.3	9.7
7.75"	5.95"	1305	4.4	6.1	7.6	9.1	10.7
7.75"	6.75"	1490	5.1	7.0	8.7	10.4	12.2
7.75"	7.25"	1600	5.5	7.5	9.3	11.2	13.1

# Specifications Model P59W

Volume .....	Up to 8.9 GPM
Discharge Pressure .....	Up to 1900 PSI
Inlet Pressure .....	Up to 1400 PSI
Speed .....	Up to 1750 RPM
Plunger Diameter .....	22mm
Stroke .....	18.1mm
Crankcase Oil Capacity .....	14 fl.oz.
Temperature of Pumped Fluids .....	Up to 160°F
Inlet Ports .....	(2) 3/8" BSP & (1) 1/2" BSP
Discharge Ports .....	(2) 3/8" BSP
Crankshaft Mounting .....	Either Side
Shaft Rotation .....	Top of Pulley Towards Fluid End
Weight .....	18 lbs.
Crankshaft Diameter .....	24mm
Volumetric Efficiency @ 1750 .....	0.95
Mechanical Efficiency @ 1750 .....	0.80

Consult the factory for special requirements that must be met if the pump is to operate beyond one or more of the limits specified above.

### PULLEY INFORMATION

Pulley selection and pump speed are based on a 1725 RPM motor and "B" section belts. When selecting desired GPM, allow for a ±5% tolerance on pumps output due to variations in pulleys, belts and motors among manufacturers.

1. Select GPM required, then select appropriate motor and pump pulley from the same line.
2. The desired pressure is achieved by selecting the correct nozzle size that corresponds with the pump GPM.

### HORSEPOWER INFORMATION

Horsepower ratings shown are the power requirements for the pump. Gas engine power outputs must be approximately twice the pump power requirements shown above.

We recommend that a 1.1 service factor be specified when selecting an electric motor as the power source. To compute specific pump horsepower requirements, use the following formula:

$$HP = (GPM \times PSI) / 1460$$

<b>P59W PULLEY SELECTION &amp; HORSEPOWER REQUIREMENTS</b>							
<b>PUMP PULLEY</b>	<b>MOTOR PULLEY</b>	<b>RPM</b>	<b>GPM</b>	<b>500 PSI</b>	<b>1000 PSI</b>	<b>1500 PSI</b>	<b>1900 PSI</b>
7.75"	4.25"	910	4.7	1.6	3.2	4.8	6.1
7.75"	4.75"	1025	5.3	1.8	3.6	5.4	6.9
7.75"	5.45"	1190	6.1	2.1	4.2	6.3	8.0
7.75"	5.95"	1305	6.7	2.3	4.6	6.9	8.8
7.75"	6.75"	1490	7.7	2.6	5.3	7.9	10.0
7.75"	7.75"	1725	8.9	3.0	6.1	9.1	

# Exploded View - P54W, P58W, P59W

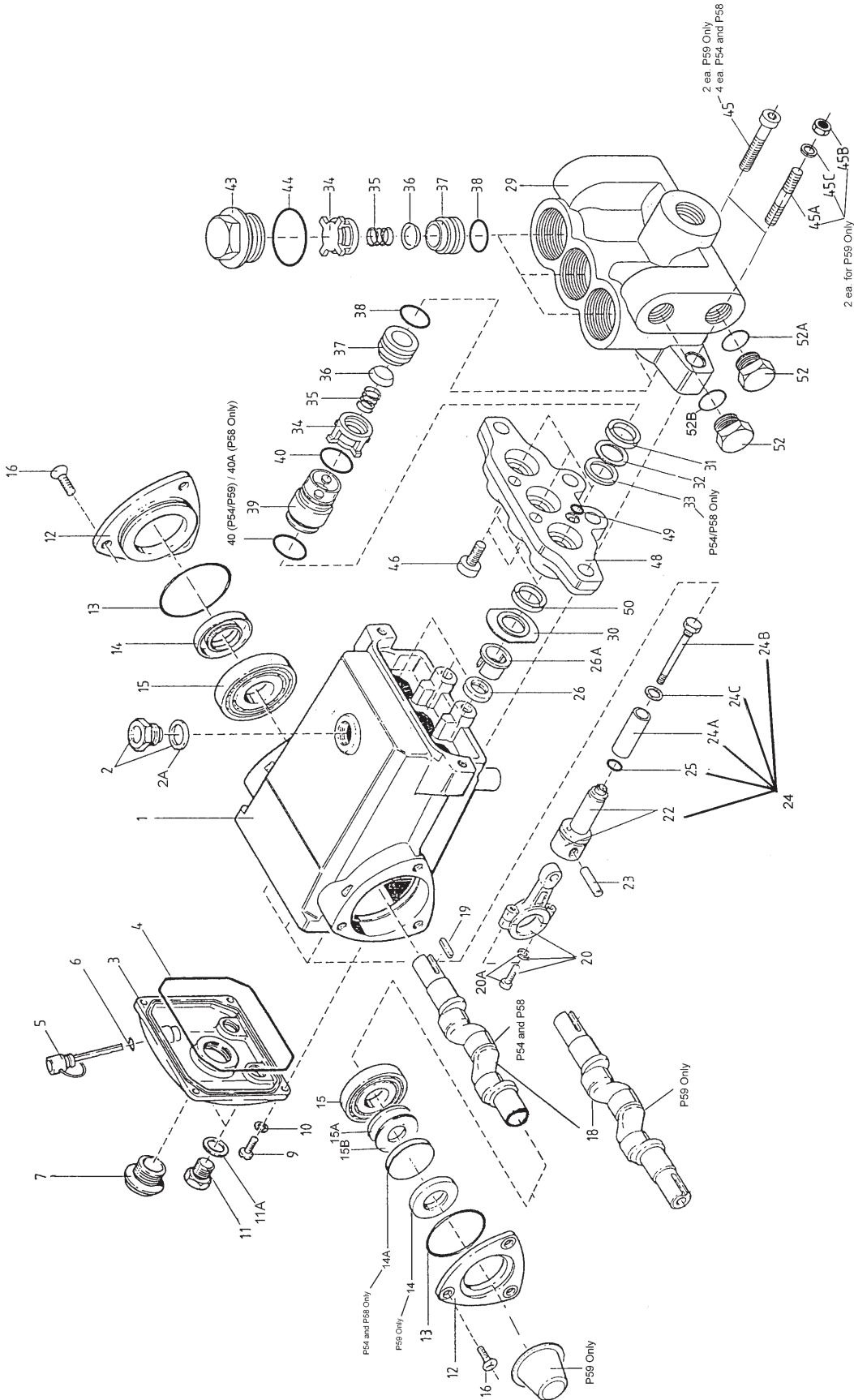

## P54W, P58W, P59W PUMP PARTS LIST

<u>ITEM</u>	<u>PART</u>	<u>DESCRIPTION</u>	<u>QTY.</u>	<u>ITEM</u>	<u>PART</u>	<u>DESCRIPTION</u>	<u>QTY.</u>
1	07180	Crankcase	1	31	08477	Grooved Seal (P58)	3
2	07181	Vent/Filler Plug with Seal	1	31	06250	Automatic Seal Ring (P59)	3
2A	07182	Gasket	1	32	07768	Support Ring (P54)	3
3	07183	Crankcase Cover	1	32	07929	Pressure Ring (P58)	3
4	07184	O-Ring	1	32	06253	Support Ring (P59)	3
5	07185	Oil Dipstick	1	33	07769	Support Ring (P54)	3
6	01009	O-Ring	1	33	12124	Support Ring (P58)	3
7	12249	Plug, 1" BSP	1	34	07492	Spring Tension Cap (P54, P58)	6
9	07188	Cylinder Screw with Slot	4	34	07326-0100	Spring Tension Cap (P59)	6
10	07223	Spring Washer	4	35	07906	Valve Spring (P54, P58)	6
11	13261	Oil Drain Plug	2	35	06017-0100	Valve Spring (P59)	6
11	07190	Oil Drain Plug (P59)	2	36	07491	Valve Plate (P54, P58)	6
11A	13262	Gasket	2	36	06016	Valve Plate (P59)	6
11A	13262	Gasket (P59)	2	37	08404	Valve Seat (P54, P58)	6
12	07192	Bearing Cover	2	37	06014	Valve Seat (P59)	6
13	07193	O-Ring	2	38	07770	O-Ring (P54, P58)	6
14	01166	Radial Shaft Seal (P54, P58)	1	38	06015	O-Ring (P59)	6
14	01166	Radial Shaft Seal (P59)	2	39	07771	Seal Case (P54)	3
14A	08439	Lid (P54, P58 Only)	1	39	12125	Seal Case (P58)	3
15	07760	Cylinder Roller Bearing	2	39	13386	Seal Case (P59)	3
15A	06245	Shim 0.2mm	1	40	07489	O-Ring (P54)	6
15B	06330	Shim 0.1mm	1	40	07489	O-Ring (P58)	3
16	07196	Countersunk Screw	6	40	07234	O-Ring (P59)	6
17	07197	Crankshaft Protector (P59 Only)	1	40A	12126	O-Ring (P58 Only)	3
18	12122	Crankshaft (P54, P58)	1	43	07772	Plug (P54, P58)	3
18	13330	Crankshaft (P59)	1	43	07213	Plug (P59)	3
19	13331	Woodruff Key	1	44	07035	O-Ring (P54, P58)	3
20	07199	Connecting Rod Assembly	3	44	07214	O-Ring (P59)	3
20A	01027	Screw with Washer	6	45	07773	Inner Hexagon Screw (P54, P58)	4
22	07777	Crosshead with Plunger Base	3	45	07773	Inner Hexagon Screw (P59)	2
23	01031	Crosshead Pin	3	45A	13387	Stud Bolt (P59 Only)	2
24	07763	Crosshead/Plunger Assy. (P54)	3	45B	08040	Hexagon Nut (P59 Only)	2
24	13332	Crosshead/Plunger Assy. (P58)	3	45C	08041	Washer (P59 Only)	2
24	13382	Crosshead/Plunger Assy. (P59)	3	46	07774	Inner Hexagon Screw (P54, P58)	2
24A	07778	Plunger Pipe (P54)	3	46	13388	Inner Hexagon Screw (P59)	2
24A	07021	Plunger Pipe (P58)	3	48	07775	Intermediate Casing (P54)	1
24A	13383	Plunger Pipe (P59)	3	48	12127	Intermediate Casing (P58)	1
24B	08456	Tension Screw	3	48	13389	Intermediate Casing (P59)	1
24C	07676	Copper Gasket	3	49	01009	O-Ring	1
25	13333	Oil Scraper	3	50	07767	Automatic Seal Ring (P54)	3
26	07206	Radial Shaft Seal	3	50	08477	Grooved Seal (P58)	3
26A	07764	Spacer Sleeve	3	50	13390	Grooved Seal (P59)	3
29	07765	Valve Casing (P54, P58)	1	52	13338	Plug, 3/8" BSP (P54, P58)	3
29	13384	Valve Casing (P59)	1	52	07109	Plug, 1/2" BSP (P59)	3
30	07766	Pressure Ring (P54)	3	52A	12007	O-Ring (P54, P58)	2
30	12123	Pressure Ring (P58)	3	52A	07110	Gasket (P59)	2
30	13385	Pressure Ring (P59)	3	52B	08486	Copper Crush Washer (P54, P58)	1
31	07767	Automatic Seal Ring (P54)	3	52B	13391	Copper Crush Washer (P59)	1

## REPAIR KITS

### Seal Kits

<b>P54W</b>			<b># 09167</b>
<u>Qty.</u>	<u>Part #</u>	<u>Description</u>	
6	07767	Automatic Seal Ring	
3	07768	Support Ring	
6	07489	O-Ring	
3	01009	O-Ring	

<b>P58W</b>			<b># 09238</b>
<u>Qty.</u>	<u>Part #</u>	<u>Description</u>	
6	08477	Grooved Seal	
3	07929	Support Ring	
3	08525	O-Ring	
3	12126	O-Ring	
3	01009	O-Ring	

<b>P59W</b>			<b># 09317</b>
<u>Qty.</u>	<u>Part #</u>	<u>Description</u>	
3	06250	Automatic Seal Ring	
3	06253	Support Ring	
6	07234	O-Ring	
3	01009	O-Ring	
3	13390	Grooved Seal	

### Valve Assembly Kits

<b>P54W &amp; P58W</b>			<b># 09168</b>
<u>Qty.</u>	<u>Part #</u>	<u>Description</u>	
3	07492	Tension Cap	
3	07906	Valve Spring	
3	07491	Valve Plate	
3	08404	Valve Seat	
3	07770	O-Ring	

<b>P59W</b>			<b># 09318</b>
<u>Qty.</u>	<u>Part #</u>	<u>Description</u>	
3	07326-0100	Tension Cap	
3	06017-0100	Valve Spring	
3	06016	Valve Plate	
3	06014	Valve Seat	
3	06015	O-Ring	

### Oil Seal Kit

<b>P54W, P58W &amp; P59W</b>			<b># 09319</b>
<u>Qty.</u>	<u>Part #</u>	<u>Description</u>	
3	07206	Radial Shaft Seal	

## P54W, P58W, P59W TORQUE SPECIFICATIONS

<u>Position</u>	<u>Item#</u>	<u>Description</u>	<u>Torque Amount</u>
20A	01027	Connecting Rod Screw	125-150 in.-lbs.
43	07772/07213	Plug	50 ft.-lbs.
45/45A	07773/13387	Inner Hexagon Screw/Stud Nut	35 ft.-lbs.



## PUMP SYSTEM MALFUNCTION

<u>MALFUNCTION</u>	<u>CAUSE</u>	<u>REMEDY</u>
The Pressure and/or the Delivery Drops	Worn packing seals Broken valve spring Belt slippage Worn or Damaged nozzle Fouled discharge valve Fouled inlet strainer Worn or Damaged hose Worn or Plugged relief valve on pump Cavitation  Unloader	Replace packing seals Replace spring Tighten or Replace belt Replace nozzle Clean valve assembly Clean strainer Repair/Replace hose Clean, Reset, and Replace worn parts Check suction lines on inlet of pump for restrictions  Check for proper operation
Water in crankcase	High humidity Worn seals	Reduce oil change interval Replace seals
Noisy Operation	Worn bearings  Cavitation	Replace bearings, Refill crankcase oil with recommended lubricant Check inlet lines for restrictions and/or proper sizing
Rough/Pulsating Operation with Pressure Drop	Worn packing Inlet restriction  Accumulator pressure Unloader Cavitation	Replace packing Check system for stoppage, air leaks, correctly sized inlet plumbing to pump Recharge/Replace accumulator Check for proper operation Check inlet lines for restrictions and/or proper size
Pressure Drop at Gun	Restricted discharge plumbing	Re-size discharge plumbing to flow rate of pump
Excessive Leakage	Worn plungers Worn packing/seals Excessive vacuum Cracked plungers Inlet pressure too high	Replace plungers Adjust or Replace packing seals Reduce suction vacuum Replace plungers Reduce inlet pressure
High Crankcase Temperature	Wrong Grade of oil Improper amount of oil in crankcase	Giant oil is recommended Adjust oil level to proper amount

## REPAIR INSTRUCTION - P54W, P58W, P59W PUMPS

### Maintenance of the Fluid End

1. With a 22mm socket, remove the three discharge valve plugs (43) from the top of the manifold.
2. With a pair of needle nose pliers, remove the discharge valve cage (34), spring (35) and plate (36).
3. Use a slide hammer with a finger attachment to remove the valve seats (37).
4. Inspect the valve seat (35) and valve plate (36) for signs of wear or cavitation and replace as necessary.
5. Using a 8mm allen wrench, remove the inner hexagon screws (45). For P59 pumps, use a crescent wrench to remove the stud nuts (45B).
6. Pull the valve casing (29) off the plungers.
7. Using a 6mm allen wrench, remove the two inner hexagon screws (46).
8. Separate the intermediate casing (48) from the valve casing (29)
9. Remove and inspect the weep seal (50) and replace if necessary.
10. Remove and inspect the high pressure seal (31), pressure ring (32) and support ring (33). Replace if needed.
11. Remove the seal case (39) from the valve casing (29) and inspect both o-rings (40 or 40A) for wear.
12. Using a needle nose pliers, remove the valve cage (34), spring (35) and valve plate (36) from the valve casing (29). Using a slide hammer with finger attachments, remove the valve seat (37) from the valve casing.
13. Inspect the valve seat (37) and valve plate (36) for wear and cavitation. Replace as needed.
14. Install the inlet valve assembly back into the valve casing (29).
15. Install the seal case (39) into the valve casing (29).
16. Install the high pressure seal (31) and pressure ring (32) and support ring (33) into the intermediate casing (48).
17. Lubricate the weep seal (50) and install into the intermediate casing (48).
18. Replace the three spacer sleeves (26A) over the plunger with the flanged side toward the valve casing (29).
19. Install the pressure rings (30) over the plungers. Slide the intermediate casing (48) over the plungers. Make sure that the o-ring (49) is in place. Place the valve casing (29) over the plungers and secure the intermediate casing to the valve casing with the inner hexagon screws (46). Secure the valve casing with the inner hexagon screws (45). For P59 pumps use the stud nuts (45B). Torque the screws and stud nuts to 35 ft.-lbs.
20. Install the three discharge valve assemblies.
21. Replace the discharge plugs (43) and torque to 50 ft.-lbs.

### Maintenance of the Gear End

1. With the valve casing (29) and intermediate casing (48) off the pump, remove the crankcase cover screws (9). Inspect the crankcase cover (3) and its o-ring (4) for wear. Replace as necessary.
2. Inspect the dipstick (5) vent hole for signs of clogging. Clean as necessary.
3. To remove the crankshaft (18), first remove the bearing cover plates (12). Remove the key (19).
4. Remove the connecting rod caps (20A) with a 5 mm allen wrench and push the connecting rod (20) and plunger rod (22) down as far as possible into the crankcase housing.
5. Hold the pump rear assembly with a wooden fixture or other suitable device, in order to secure it while removing the crankshaft (18). Using a plastic mallet, tap the crankshaft from one side

## REPAIR INSTRUCTION - P54W, P58W, P59W PUMPS

while turning it from the other side. This turning ensures that during this sequence the crankshaft does not become wedged against the connecting rods (20). The far side bearing (15) will remain in the crankcase (1). When free, the crankshaft can be removed by hand. The far side crankshaft seal (14) will be removed by this procedure.

6. If necessary, use a bearing puller to remove the crankshaft bearing (15).
7. Remove the connecting rod and plunger rod/crosshead assembly from the rear of the pump by pulling straight out of the crosshead guides.
8. Using a dowel and rubber mallet, tap the oil seals (26) out from the rear of the crankcase (1).
9. To remove the crosshead pin (23) from the crosshead (22), place the assembly on a wooden fixture to avoid damage to the crosshead. Drive out the pin on the opposite side of the mark on the crosshead. On those pumps without a mark on the crosshead, drive out the pin by tapping out the tapered side of the pin.
10. To remove the bearing (15) remaining in the crankcase (1), insert the small end of a bearing tool and tap with a rubber mallet until the bearing and seal (14) are completely removed. The bearing can only be removed from the inside by inserting a bearing tool through the opposite side of the crankcase. The crosshead guide in the crankcase should be inspected for possible damage.
11. To reassemble, place the far bearing (15) in the crankcase bearing housing. With the bearing tool as a driver, tap into the crankcase using a rubber mallet.
12. Before reinserting into the pump, make sure that the crankshaft seal (14) lip does not show signs of wear and that the garter spring is firmly in place on the seal. With the bearing tool, insert the far side seal. Make sure the seal is firmly seated and well oiled. Replace the bearing cover (12) and tighten securely.
13. Replace the connecting rod (20) and plunger rod/ crosshead assembly by press-fitting the crosshead pin (23). Make sure to insert the beveled edge of the crosshead pin into crosshead. If the crosshead has a mark, install pin from marked side. The crosshead pin should not extend beyond either side of the crosshead in order to prevent damage to the crosshead bore of the crankcase.
14. Generously lubricate (with oil) the crosshead/ plunger assembly into the crankcase. Notice that the connecting rod halves are numbered or colored. Position the connecting rods with their numbers or colors on the upper left-hand side, in the same numerical sequence in which they were removed.
15. Replace near side bearing (15) on crankshaft (18) by using a bearing tool and mallet to tap into place. Attention must be paid during repair work that the outer bearing ring (15) is placed firmly against the bearing cover (12) on one side. On the opposite side, a correct amount of shims (15A & 15B) are to be inserted between the outer bearing cover (12) and bearing (15) so that the shaft can turn easily with very little clearance.
16. Take the crankshaft end with the bearing and insert the other end through the bearing housing and tap with a rubber mallet until the bearing is seated.
17. When reassembling the connecting rod (20) halves, note that the connecting rod halves are numbered or colored and that the numbers or colors must be matched and aligned. Torque the connecting rod bolts to 125-150 in. lbs.
18. Before installation, apply a small amount of loctite to the O.D. of the crankcase oil seal (26). The oil seal should be installed so that the grooved side of the seal will face the crankcase (1). Tap seal in place using a socket and rubber mallet.
19. Again lubricate the plungers. Reinstall the intermediate casing (48) and valve casing (29) over the plungers.
20. Clean the back edge of crankcase (1) and replace the crankcase cover (3). Be careful not to pinch the crankcase cover o-ring (4).
21. Fill the crankcase (1) with 14 oz. of oil. Check the oil level with the dipstick (5). The oil level should be between the two lines.

## P54, P58, & P59 PUMP DIMENSIONS (inches)

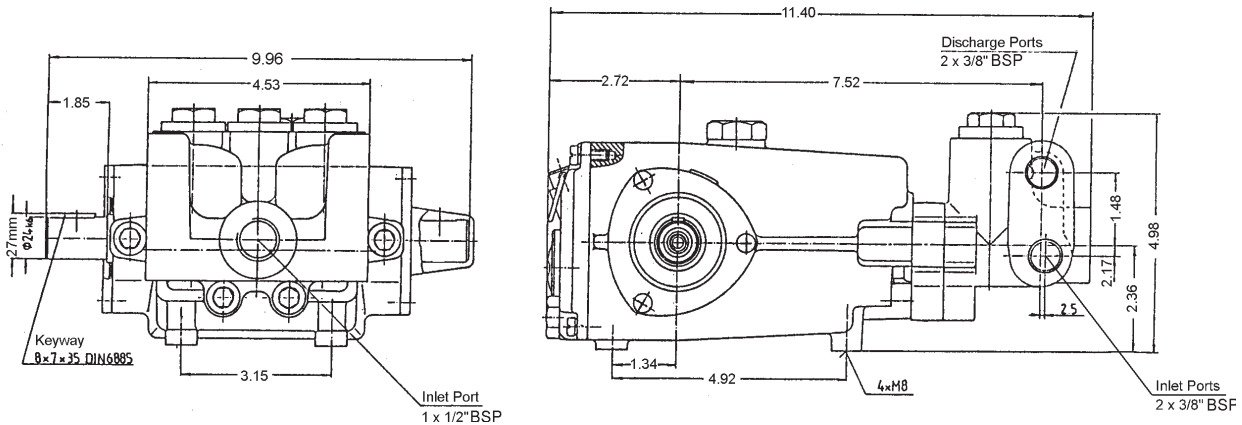

### GIANT INDUSTRIES LIMITED WARRANTY

Giant Industries, Inc. pumps and accessories are warranted by the manufacturer to be free from defects in workmanship and material as follows:

1. For portable pressure washers and car wash applications, the discharge manifolds will never fail, period. If they ever fail, we will replace them free of charge. Our other pump parts, used in portable pressure washers and in car wash applications, are warranted for five years from the date of shipment for all pumps used in NON-SALINE, clean water applications.

2. One (1) year from the date of shipment for all other Giant industrial and consumer pumps.
3. Six (6) months from the date of shipment for all rebuilt pumps.
4. Ninety (90) days from the date of shipment for all Giant accessories.

This warranty is limited to repair or replacement of pumps and accessories of which the manufacturer's evaluation shows were defective at the time of shipment by the manufacturer. The following items are NOT covered or will void the warranty:

1. Defects caused by negligence or fault of the buyer or third party.
2. Normal wear and tear to standard wear parts.
3. Use of repair parts other than those manufactured or authorized by Giant.
4. Improper use of the product as a component part.
5. Changes or modifications made by the customer or third party.
6. The operation of pumps and or accessories exceeding the specifications set forth in the Operations Manuals provided by Giant Industries, Inc.

Liability under this warranty is on all non-wear parts and limited to the replacement or repair of those products returned freight prepaid to Giant Industries which are deemed to be defective due to workmanship or failure of material. A Returned Goods Authorization (R.G.A.) number and completed warranty evaluation form is required prior to the return to Giant Industries of all products under warranty consideration. Call (419)-531-4600 or fax (419)-531-6836 to obtain an R.G.A. number.

Repair or replacement of defective products as provided is the sole and exclusive remedy provided hereunder and the MANUFACTURER SHALL NOT BE LIABLE FOR FURTHER LOSS, DAMAGES, OR EXPENSES, INCLUDING INCIDENTAL AND CONSEQUENTIAL DAMAGES DIRECTLY OR INDIRECTLY ARISING FROM THE SALE OR USE OF THIS PRODUCT.

THE LIMITED WARRANTY SET FORTH HEREIN IS IN LIEU OF ALL OTHER WARRANTIES OR REPRESENTATION, EXPRESS OR IMPLIED, INCLUDING WITHOUT LIMITATION ANY WARRANTIES OR MERCHANTABILITY OR FITNESS FOR A PARTICULAR PURPOSE AND ALL SUCH WARRANTIES ARE HEREBY DISCLAIMED AND EXCLUDED BY THE MANUFACTURER.



GIANT INDUSTRIES, INC., 900 N. Westwood Ave., P.O. Box 3187, Toledo, Ohio 43607

PHONE (419) 531-4600, FAX (419) 531-6836, www.giantpumps.com 2/98P54-59.PM6  
© Copyright 1998 Giant Industries, Inc.