

Model P460A

Triplex Ceramic
Plunger Pump
Operating Instructions/
Repair and Service
Manual

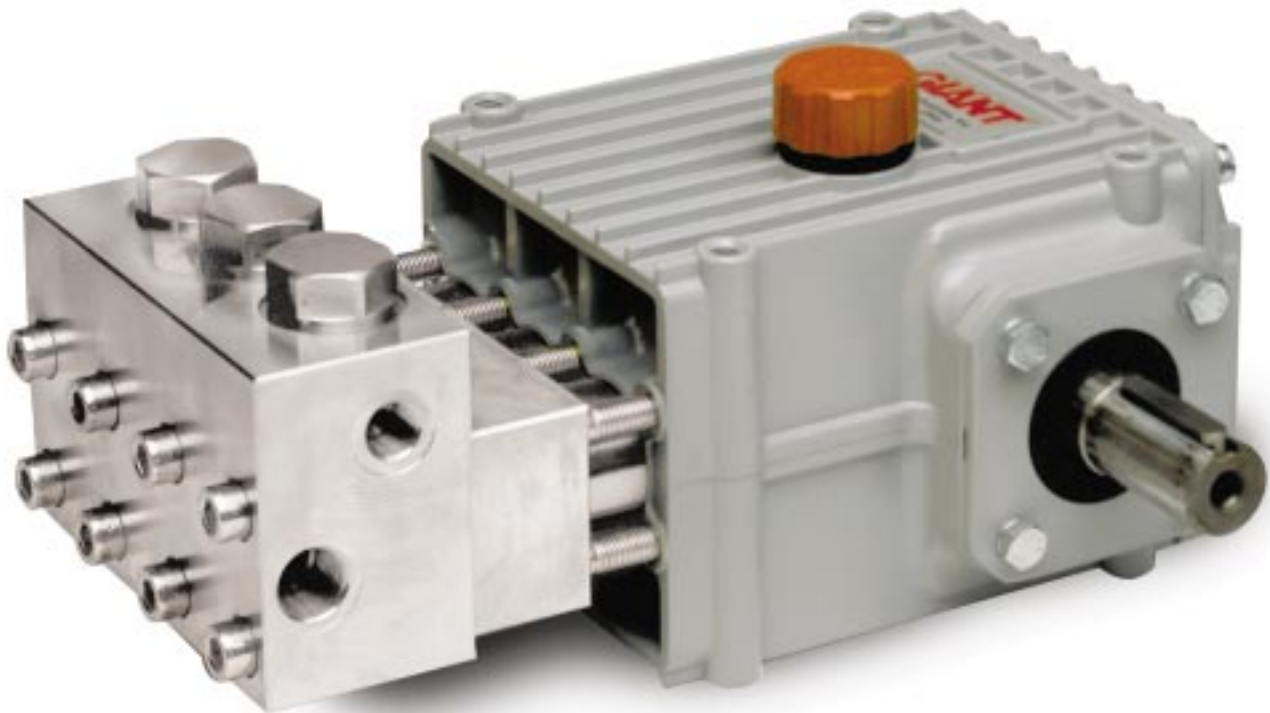

GIANT

Contents:

Installation Instructions:	page 2
Pump Specifications:	page 3
Parts List/Torque Specs:	page 4
Exploded View/Kits:	page 5
P460A Specs:	pages 8-9
Repair Instructions:	pages 10-11
Dimensions:	back page
Warranty Information	back page

Updated 7/00

INSTALLATION INSTRUCTIONS

Installation of the Giant Industries, Inc., pump is not a complicated procedure, but there are some basic steps common to all pumps. The following information is to be considered as a general outline for installation. If you have unique requirements, please contact Giant Industries, Inc. or your local distributor for assistance.

1. The pump should be installed flat on a base to a maximum of a 15 degree angle of inclination to ensure optimum lubrication.
2. The inlet to the pump should be sized for the flow rate of the pump with no unnecessary restrictions that can cause cavitation. Teflon tape should be used to seal all joints. If pumps are to be operated at temperatures in excess of 104° F, it is important to insure a positive head to the pump to prevent cavitation.
3. The discharge plumbing from the pump should be properly sized to the flow rate to prevent line pressure loss to the work area. It is essential to provide a safety bypass valve between the pump and the work area to protect the pump from pressure spikes in the event of a blockage or the use of a shut-off gun.

4. Use of a dampener is necessary to minimize pulsation at drive elements, plumbing, connections, and other system areas. The use of a dampener with Giant Industries, Inc. pumps is optional, although recommended by Giant Industries, Inc. to further reduce system pulsation. Dampeners can also reduce the severity of pressure spikes that occur in systems using a shut-off gun. A dampener must be positioned downstream from the unloader.

5. Crankshaft rotation on Giant Industries, Inc. pumps should be made in the direction designated by the arrows on the pump crankcase. Reverse rotation may be safely achieved by following a few guidelines available upon request from Giant Industries, Inc. Required horsepower for system operation can be obtained from the charts on pages 3-5 and 8-9.

6. Before beginning operation of your pumping system, remember: Check that the crankcase and seal areas have been properly lubricated per recommended schedules. Do not run the pump dry for extended periods of time. Cavitation will result in severe damage. Always remember to check that all plumbing valves are open and that pumped media can flow freely to the inlet of the pump.

Finally, remember that high pressure operation in a pump system has many advantages. But, if it is used carelessly and without regard to its potential hazard, it can cause serious injury.

IMPORTANT OPERATING CONDITIONS

Failure to comply with any of these conditions invalidates the warranty.

1. Prior to initial operation, add oil to the crankcase so that oil level is between the two lines on the oil dipstick. **DO NOT OVERFILL.**

Use Giant Synthetic Oil

Crankcase oil should be changed after the first 50 hours of operation, then at regular intervals of 500 hours or less depending on operating conditions.

2. Pump operation must not exceed rated pressure, volume, or RPM. A pressure relief device must be installed in the discharge of the system.

3. Acids, alkalines, or abrasive fluids cannot be pumped unless approval in writing is obtained before operation from Giant Industries, Inc.

4. Run the pump dry approximately 10 seconds to drain the water before exposure to freezing temperatures.

NOTE: Contact Giant Industries for Service School Information. Phone: (419)-531-4600

Specifications Model P460A

Volume	Up to 3.8 (14.5 l/min) GPM
Discharge Pressure	Up to 7250 PSI (500 Bar)
Inlet Pressure	Up to 145 PSI (10 Bar)
Stroke	24mm
RPM	Up to 1450 RPM
Plunger Diameter	14mm
Temperature of Pumped Fluids	Up to 104 °F (40°C)
Inlet Ports	(2) 1/2" BSP
Discharge Ports	(2) 3/4" BSP
Shaft Rotation	Top of pulley towards fluid end
Crankshaft Diameter	28mm
Key Width	8mm
Shaft Mounting	Either side ¹
Weight	37lbs. 8oz. (17kg)
Crankcase Capacity	30fl.oz.
Volumetric Efficiency @ 1450 RPM	0.90
Mechanical Efficiency @ 1450 RPM	0.80

Consult the factory for special requirements that must be met if the pump is to operate beyond one or more of the limits specified above.

NOTES:

In order to drive the pump from the side opposite the present shaft extension, simply remove the valve casing from the crankcase and rotate the pumps 180 degrees to the desired position. Be certain to rotate the seal case (item #20) as well, so that the weep holes are down at the six o'clock position. Exchange the oil fill and the oil drain plugs, also. Refer to the repair instructions as necessary for the proper assembly sequence.

P460A HORSEPOWER REQUIREMENTS

RPM	GPM	4000 PSI	5000 PSI	5800 PSI	6500 PSI	7250 PSI
1000	2.6	7.6	9.6	11.1	12.4	13.9
1100	2.9	8.5	10.7	12.4	13.9	15.5
1200	3.2	9.4	11.8	13.6	15.3	17.1
1300	3.4	10.0	12.5	14.5	16.3	18.1
1450	3.8	11.2	14.0	16.2	18.2	20.3

HORSEPOWER RATINGS:

The rating shown are the power requirements for the pump. Gas engine power outputs must be approximately twice the pump power requirements shown above.

We recommend a 1.15 service factor be specified when selecting an electric motor as the power source. To compute specific pump horse power requirements, use the following formula:

$$HP = (GPM \times PSI) / 1360$$

SPECIAL NOTE:

The theoretical gallons per revolution (gal/rev) is 0.00264
To find specific outputs at various RPM, use the formula: GPM = 0.00264 x

RPM

P460A PARTS LIST

<u>ITEM</u>	<u>PART</u>	<u>DESCRIPTION</u>	<u>QTY.</u>	<u>ITEM</u>	<u>PART</u>	<u>DESCRIPTION</u>	<u>QTY.</u>
1	08377	Crankcase	1	20	06481	Seal Adapter	3
2	08378	Oil Fill Plug with Gasket	1	20A	06482	Seal Case	1
3	06479	Crankcase Cover	1	21	07266	O-Ring	3
3A	07186	Oil Sight Glass w/Gasket	1	22	08059	O-Ring	3
4	08380	O-Ring	1	23	06483	Grooved Seal Packing	6
5	07109	Oil Drain Plug	1	23A	13036	Spacer Ring	3
5A	07182	Gasket for Oil Drain Plug	1	24	06484	Pressure Ring	3
5B	08092	Plug with Gasket	1	25	06485	Weep Return Ring	3
6	01010	Screw	4	25A	06486	Support Ring	6
6A	01011	Spring Washer	4	25B	06487	O-Ring	6
7	08471	Bearing Cover Open	1	26	06488	Valve Casing	1
8	08472	Bearing Cover Closed	1	27A	06489	Valve Assy. (Includes items 27-31A)	6
8A	06245	Shim	1	27	06490	Valve Seat	6
8B	06330	Shim	1	28	06491	Valve Plate	6
9	01016	O-Ring	2	29	07906	Valve Spring	6
10	07114	Screw with Washer	8	30	07907	Valve Spring Retainer	6
11	07459	Radial Shaft Seal	1	31	07770	O-Ring	6
12	08473	Bearing	1	31A	06492	Support Ring	6
12A	08474	Bearing	1	32	06493	Plug	3
13	08475	Crankshaft	1	33	07489	O-Ring	3
14	08091	Fitting Key	1	34	06494	Cap Screw	8
15	08390	Connecting Rod Assy.	3	36	12256	Plug, 3/8" BSP	1
15A	07311	Screw with Washer	6	37	08486	Copper Washer	1
16	06480	Plunger Assy.	3	38	07109	Plug	1
17	07314	Crosshead Pin	3	39	06272	Copper Washer	1
19	08366	Oil Seal	3				

P460A TORQUE SPECIFICATIONS

<u>Item</u>	<u>Part #</u>	<u>Description</u>	<u>Torque Amount</u>
15A	07311	Screw with Washer	216 in.-lbs.
32	06493	Plug	110 ft.-lbs.
34	06494	Cap Screw	36 ft.-lbs.

Exploded View - P460A

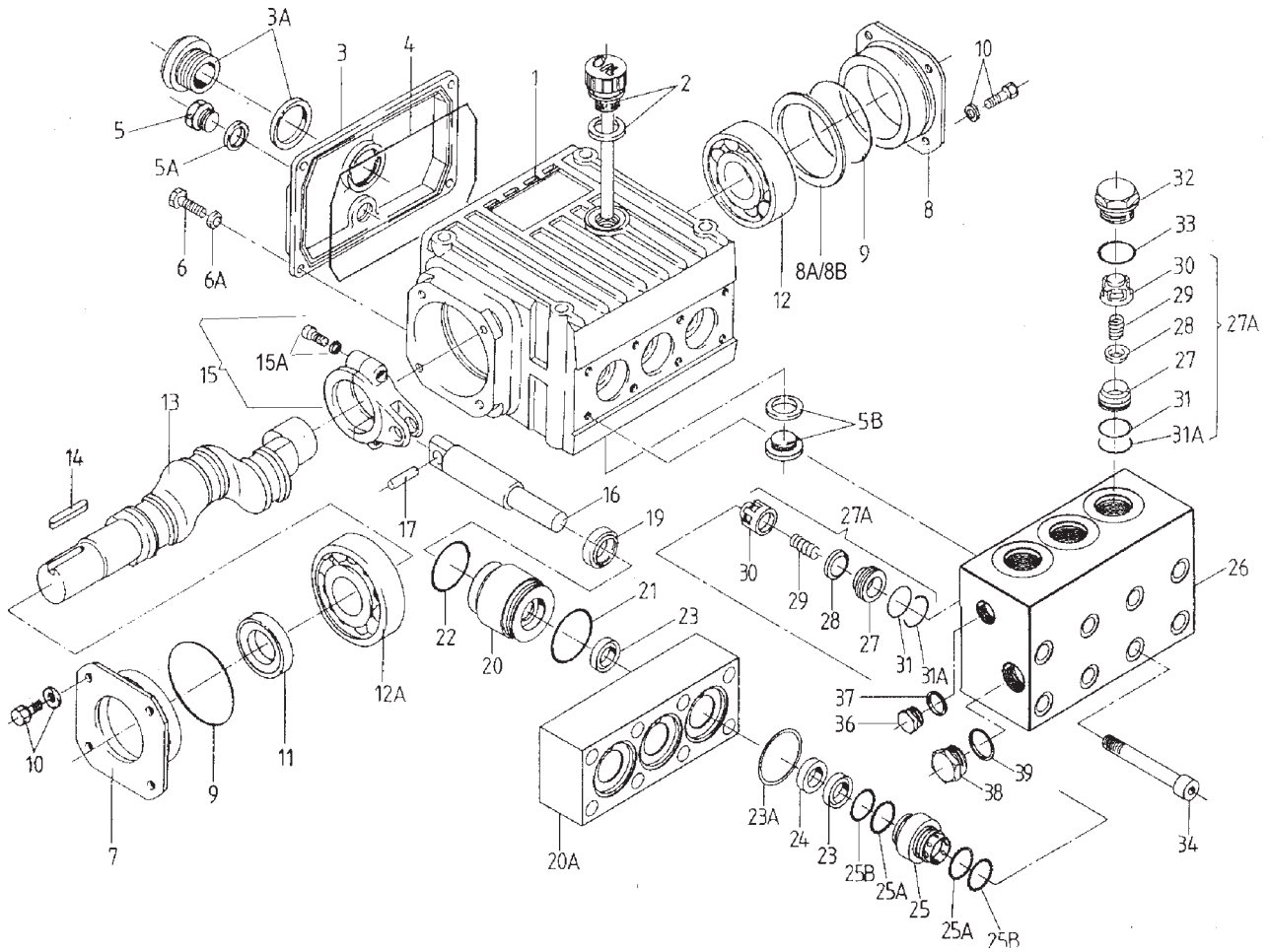

P460A REPAIR KITS

Plunger Packing Kits

Part # 09499

Item	Qty.	Part #	Description
21	3	07266	O-Ring
22	3	08059	O-Ring
23	6	06483	Grooved Seal Packing
24	3	06484	Pressure Ring

Oil Seal Kit

Part # 09306

Item	Qty.	Part #	Description
19	3	08366	Oil Seal

Valve Assembly Kits

Part # 09498

Item	Qty.	Part #	Description
27A	6	06489	Valve Assembly, Complete
31	6	07770	O-Ring
31A	6	06492	Support Ring

PUMP SYSTEM MALFUNCTION

<u>MALFUNCTION</u>	<u>CAUSE</u>	<u>REMEDY</u>
The Pressure and/ or the Delivery Drops	Worn packing seals Broken valve spring Belt slippage Worn or Damaged nozzle Fouled discharge valve Fouled inlet strainer Worn or Damaged hose Worn or Plugged relief valve on pump Cavitation pump for restrictions Unloader	Replace packing seals Replace spring Tighten or Replace belt Replace nozzle Clean valve assembly Clean strainer Repair/Replace hose Clean, Reset, and Replace worn parts Check suction lines on inlet of Check for proper operation
Water in crankcase	High humidity Worn seals	Reduce oil change interval Replace seals
Noisy Operation	Worn bearings Cavitation	Replace bearings, Refill crankcase oil with recommended lubricant Check inlet lines for restrictions and/or proper sizing
Rough/Pulsating Operation with Pressure Drop	Worn packing Inlet restriction Accumulator pressure Unloader Cavitation and/or proper size	Replace packing Check system for stoppage, air leaks, correctly sized inlet plumbing to pump Recharge/Replace accumulator Check for proper operation Check inlet lines for restrictions
Pump Pressure as at gun Rated, Pressure	Restricted discharge plumbing	Re-size discharge plumbing to Drop flow rate of pump
Excessive Leakage	Worn plungers Worn packing/seals Excessive vacuum Cracked plungers Inlet pressure too high	Replace plungers Adjust or Replace packing seals Reduce suction vacuum Replace plungers Reduce inlet pressure
High Crankcase Temperature	Wrong Grade of oil Improper amount of oil in crankcase	Giant oil is recommended Adjust oil level to proper amount

REASSEMBLY INSTRUCTIONS - P460A PUMP

Inlet Valves

Remove inner hexagon screws (34) and pull off valve casing (26) to the front. Take out seal case (25) from valve casing (26). Remove the exposed inlet valve with a pair of flat nose pliers and the valve seat (27) with a valve puller. Disassemble parts and examine valve plate (28), valve seat (27), O-ring (31) and support ring (31A). Replace worn parts. Tighten inner hexagon screws (34) again at 36 ft-lbs. (49Nm).

Discharge Valves: With a socket 32mm wrench, screw out valve plugs (32). Remove the exposed discharge valves with a pair of flat nose pliers and the valve seat (27) with a valve seat puller. Disassemble parts and examine valve plate (28), valve seat (27), O-rings (31, 33) and support ring (31A). Replace worn parts. Take care to reassemble in correct sequence. Tighten plugs (32) at 110 ft-lbs. (150Nm).

Seals

Screw out oil drain plug (5) and drain oil. Remove inner hexagon screws (34) and pull off valve casing (26) frontwise over the plungers (16). Remove seal cases (25) situated either in valve casing (26) or seal casing (20A). Separate seal casing (20A) from seal retainers (20). Remove grooved ring (23) and guide ring (24) from the seal casing (20A). Examine O-rings (25B) and support rings (25A) attached to seal cases (25). Check seal ring (23A) situated between valve casing and seal casing, and replace if necessary. Then remove seal retainers (20) from crankcase (1). Pull grooved ring (23) out of seal retainer (20). Check O-rings (21, 22). Grease new seals and O-rings before reinstallation.

Important! The grooved seal (23) on the high-pressure side is to be fitted carefully into the seal casing (20A) using a 22mm plastic rod. Under no circumstances must the surface in the seal casing or the seal lip of the grooved seal be damaged.

Check surfaces of plunger (16). Damaged surfaces cause hard wear on seals. Deposits of all kinds must be removed from the plungers.

Important! The plunger surfaces are not to be damaged. If there are lime deposits in the pump, care must be taken that the drip-return bore in parts (25) and (26) ensure trouble-free drip-return.

If the plunger (16) is worn, the complete plunger must be changed. The ceramic pipe alone cannot be changed due to reasons of precision. When reassembling tighten inner hexagon screw (34) to 36 ft-lbs. (49Nm).

If the plunger (16) is worn, the complete plunger must be changed. The ceramic pipe alone cannot be changed due to reasons of precision. When reassembling tighten inner hexagon screw (34) to 36 ft-lbs (49Nm).

Gear and Plunger

If oil leaks where the plunger (16) protrudes out of the gear, gear seals (19) and plungers have to be examined and replaced as necessary.

Gear Seal

Remove plug (5) and drain oil.

Remove valve casing as described above. Take seal adapter (20) off plunger (16) and replace gear seal (19).

Plungers

Drain oil and remove crankcase cover (3). Take off screws on con rods (15). Be careful not to mix up the con rod halves. Push con rod shaft as far as possible into the crosshead guide. Loosen screws (10) and remove bearing covers (7&8) with the help of a screw-driver.

Take crankshaft out carefully so as not to bend the con rods. Remove and dismantle con rods and plungers (18). Replace worn parts.

To reinstall, insert con rods and plungers, put crankshaft in carefully and then push the bearing covers (7&8) onto the ends of the crankshaft. Screw on bearing covers with screws (10). Mount con rod halves and tighten screws (15) to 265 in-lbs. (30Nm). Mount crankcase cover (3) together with O-ring (4).

To rotate crankshaft to the opposite side.

The shaft end is on the left side of the pump looking at it from behind. If it should be on the other side, the valve casing (26) and seal casing (20A) have to be removed, turned by 180° and then put on again. Turn seal adapters (20) by 180° so that the leakage holes are underneath. Oil dipstick (2) and oil drain plug (58) have to be interchanged and crankcase cover turned by 180°.

Contact Giant Industries for service school information. Phone: (419) 531-4600

MODEL P460A DIMENSIONS (mm)

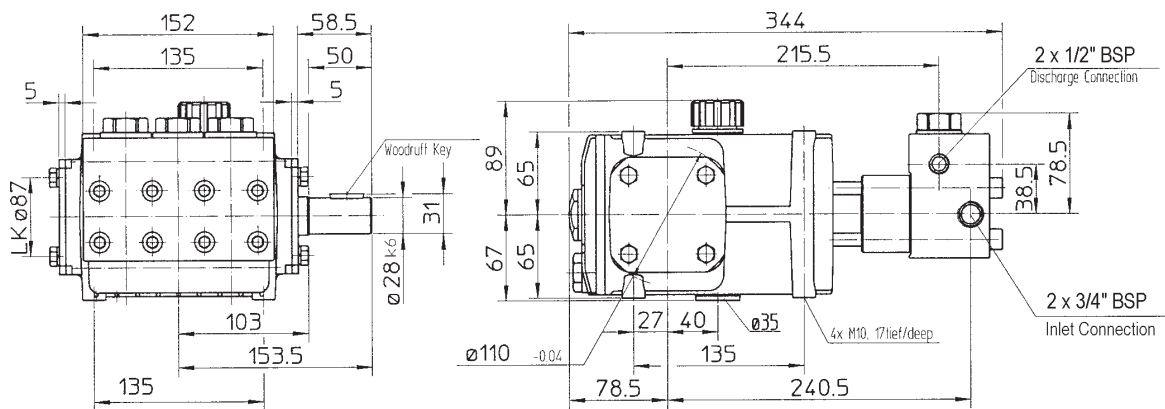

GIANT INDUSTRIES LIMITED WARRANTY

Giant Industries, Inc. pumps and accessories are warranted by the manufacturer to be free from defects in workmanship and material as follows:

1. For portable pressure washers and self-service car wash applications, the discharge manifolds will never fail, period. If they ever fail, we will replace them free of charge. Our other pump parts, used in portable pressure washers and in car wash applications, are warranted for five years from the date of shipment for all pumps used in NON-SALINE, clean water applications.
2. One (1) year from the date of shipment for all other Giant industrial and consumer pumps.
3. Six (6) months from the date of shipment for all rebuilt pumps.
4. Ninety (90) days from the date of shipment for all Giant accessories.

This warranty is limited to repair or replacement of pumps and accessories of which the manufacturer's evaluation shows were defective at the time of shipment by the manufacturer. The following items are NOT covered or will void the warranty:

1. Defects caused by negligence or fault of the buyer or third party.
2. Normal wear and tear to standard wear parts.
3. Use of repair parts other than those manufactured or authorized by Giant.
4. Improper use of the product as a component part.
5. Changes or modifications made by the customer or third party.
6. The operation of pumps and or accessories exceeding the specifications set forth in the Operations Manuals provided by Giant Industries, Inc.

Liability under this warranty is on all non-wear parts and limited to the replacement or repair of those products returned freight prepaid to Giant Industries which are deemed to be defective due to workmanship or failure of material. A Returned Goods Authorization (R.G.A.) number and completed warranty evaluation form is required prior to the return to Giant Industries of all products under warranty consideration. Call (419)-531-4600 or fax (419)-531-6836 to obtain an R.G.A. number.

Repair or replacement of defective products as provided is the sole and exclusive remedy provided hereunder and the MANUFACTURER SHALL NOT BE LIABLE FOR FURTHER LOSS, DAMAGES, OR EXPENSES, INCLUDING INCIDENTAL AND CONSEQUENTIAL DAMAGES DIRECTLY OR INDIRECTLY ARISING FROM THE SALE OR USE OF THIS PRODUCT.

THE LIMITED WARRANTY SET FORTH HEREIN IS IN LIEU OF ALL OTHER WARRANTIES OR REPRESENTATION, EXPRESS OR IMPLIED, INCLUDING WITHOUT LIMITATION ANY WARRANTIES OR MERCHANTABILITY OR FITNESS FOR A PARTICULAR PURPOSE AND ALL SUCH WARRANTIES ARE HEREBY DISCLAIMED AND EXCLUDED BY THE MANUFACTURER.



GIANT INDUSTRIES, INC., 900 N. Westwood Ave., P.O. Box 3187, Toledo, Ohio 43607

PHONE (419) 531-4600, FAX (419) 531-6836, www.giantpumps.com 7/00 P460A.PM6
© Copyright 2000 Giant Industries, Inc.