

Model LP121A-5100

Triplex Ceramic
Plunger Pump
Operating Instructions/
Repair and Service
Manual

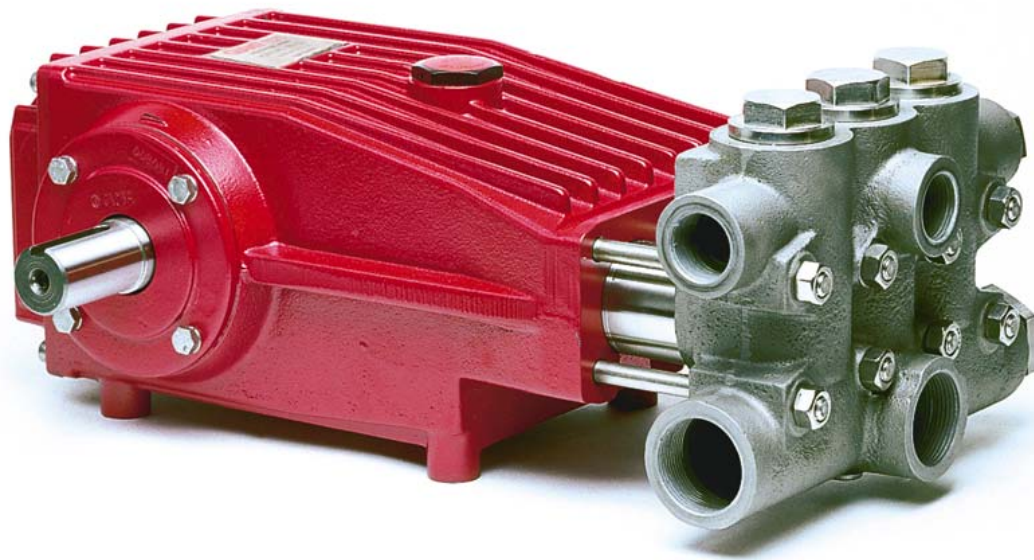

GIANT

Contents:

Installation Instructions:	page 2
Pump Specifications:	page 3
Exploded View:	page 4
Parts List/Kits:	page 5
Repair Instructions:	pages 6-8
Trouble Shooting:	page 9
Recommended Spare Parts List/Pump Mounting Selection Guide/Torque Specifications:	page 10
Dimensions:	page 11

Updated 11/02

INSTALLATION INSTRUCTIONS

Installation of the Giant Industries, Inc., pump is not a complicated procedure, but there are some basic steps common to all pumps. The following information is to be considered as a general outline for installation. If you have unique requirements, please contact Giant Industries, Inc. or your local distributor for assistance.

1. The pump should be installed flat on a base to a maximum of a 15 degree angle of inclination to ensure optimum lubrication.
2. The inlet to the pump should be sized for the flow rate of the pump with no unnecessary restrictions that can cause cavitation. Teflon tape should be used to seal all joints. If pumps are to be operated at temperatures in excess of 160° F, it is important to insure a positive head to the pump to prevent cavitation. See NPSH curve.
3. The discharge plumbing from the pump should be properly sized to the flow rate to prevent line pressure loss to the work area. It is essential to provide a safety bypass valve between the pump and the work area to protect the pump from pressure spikes in the event of a blockage or the use of a shut-off gun.

4. Use of a dampener is necessary to minimize pulsation at drive elements, plumbing, connections, and other system areas. The use of a dampener with Giant Industries, Inc. pumps is optional, although recommended by Giant Industries, Inc. to further reduce system pulsation. Dampeners can also reduce the severity of pressure spikes that occur in systems using a shut-off gun. A dampener must be positioned downstream from the unloader.

5. Crankshaft rotation on Giant Industries, Inc. pumps should be made in the direction designated by the arrows on the pump crankcase. Reverse rotation may be safely achieved by following a few guidelines available upon request from Giant Industries, Inc. Required horsepower for system operation can be obtained from the charts on pages 3.

6. Before beginning operation of your pumping system, remember: Check that the crankcase and seal areas have been properly lubricated per recommended schedules. Do not run the pump dry for extended periods of time. Cavitation will result in severe damage. Always remember to check that all plumbing valves are open and that pumped media can flow freely to the inlet of the pump.

Finally, remember that high pressure operation in a pump system has many advantages. But, if it is used carelessly and without regard to its potential hazard, it can cause serious injury.

IMPORTANT OPERATING CONDITIONS

Failure to comply with any of these conditions invalidates the warranty.

1. Prior to initial operation, add oil to the crankcase so that oil level is between the two lines on the oil dipstick. **DO NOT OVERFILL.**

Use Giant Recommended Oil

Crankcase oil should be changed after the first 50 hours of operation, then at regular intervals of 500 hours or less depending on operating conditions.

2. Pump operation must not exceed rated pressure, volume, or RPM. A pressure relief device must be installed in the discharge of the system.

3. Acids, alkalines, or abrasive fluids cannot be pumped unless approval in writing is obtained before operation from Giant Industries, Inc.

4. Run the pump dry approximately 10 seconds to drain the water before exposure to freezing temperatures.

NOTE: Contact Giant Industries for Service School Information. Phone: (419)-531-4600

Specifications

Model LP121A-5100

Volume	Up to 31.7 GPM (120 LPM)
Discharge Pressure	Up to 1740 PSI (120 Bar)
Inlet Pressure	Up to 90 PSI (6.2 Bar)
Speed	Up to 1000 RPM
Plunger Diameter	36 mm
Stroke	42 mm
Crankcase Oil Capacity	116 fl.oz. (3,430 ml)
Temperature of Pumped Fluids	Up to 160°F (71°C)
Inlet Port	3 x 1-1/2" BSPP
Discharge Port	3 x 1" BSPP
Crankshaft Mounting	Either Side
Shaft Rotation	Top of Pulley Towards Fluid End
Weight	116 lbs. (52.6 kg)
Crankshaft Diameter	35 mm
Valve Casing	316 S.S.
Volumetric Efficiency @ 800 RPM	0.96
Mechanical Efficiency @ 800 RPM	0.85

PULLEY INFORMATION

Pulley selection and pump speed are based on a 1725 RPM motor and "B" section belts. When selecting desired GPM, allow for a ±5% tolerance on pumps output due to variations in pulleys, belts and motors among manufacturers.

1. Select GPM required, then select appropriate motor and pump pulley from the same line.
2. The desired pressure is achieved by selecting the correct nozzle size that corresponds with the pump GPM.

HORSEPOWER INFORMATION

We recommend that a 1.1 service factor be specified when selecting an electric motor as the power source. To compute specific pump horsepower requirements, use the following formula:

$$HP = (GPM \times PSI) / 1440$$

Pump speeds of 640 RPM and above require a minimum inlet pressure of 12 psig.
Pump speeds of 805 RPM and above require a minimum inlet pressure of 14 psig.

LP121-5100 PULLEY SELECTION AND HORSEPOWER REQUIREMENTS								
PUMP PULLEY	MOTOR PULLEY	GPM	RPM	600 PSI	800 PSI	1000 PSI	1300 PSI	1740 PSI
12.75"	3.95"	15.9	500	6.6	8.8	11.0	14.4	19.2
12.75"	4.35"	17.6	555	7.3	9.8	12.2	15.9	21.3
12.75"	4.95"	20.3	640	8.5	11.3	14.1	18.3	24.5
12.75"	5.35"	22.0	695	9.2	12.2	15.3	19.9	26.6
12.75"	5.75"	23.8	750	9.9	13.2	16.5	21.5	28.8
12.75"	6.15"	25.4	800	10.6	14.1	17.6	22.9	30.7
12.75"	6.50"	31.7	1000	13.2	17.6	22.0	28.6	38.3

Exploded View - LP121A-5100

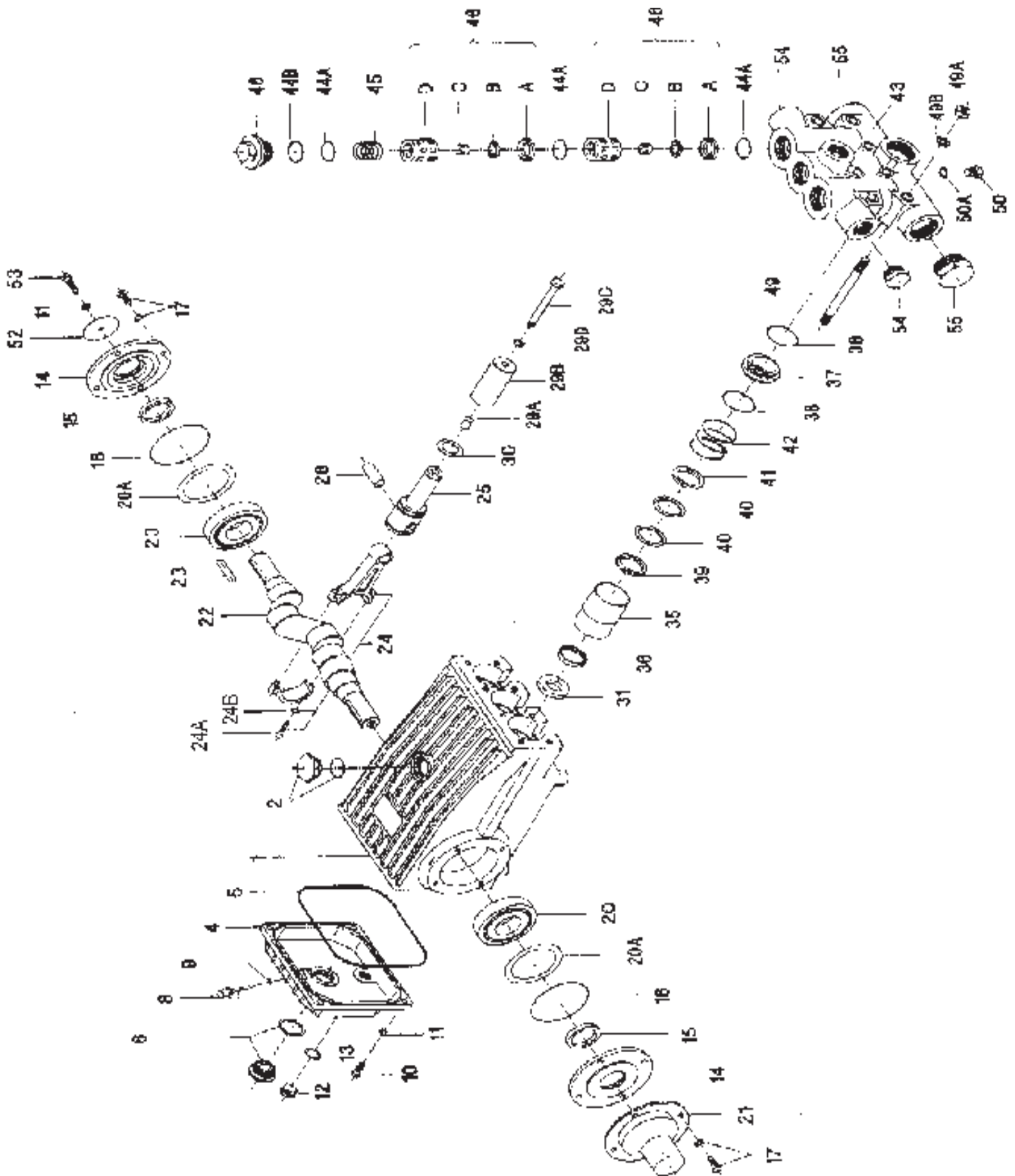

SPARE PARTS LIST - LP121A-5100 PUMP

ITEM	PART NO.	DESCRIPTION	QTY.	ITEM	PART NO.	DESCRIPTION	QTY.
1	07759	Crankcase	1	30	07779	Flinger	3
2	13000	Oil Filler Plug	1	31	07133	Radial Shaft Seal	3
4	06085	Crankcase Cover	1	35	07135-0100	Seal Sleeve	3
5	07104	O-Ring	1	36	13291	Grooved Ring	3
6	07186	Oil Sight Glass W/Gasket	1	37	07139-0100	Seal Case	3
8	06086	Oil Dipstick	1	38	07140	O-Ring	3
9	01009	O-Ring	1	39	07142-0100	Pressure Ring	3
10	08093	Screw	4	40	07144	Sleeve	6
11	08094	Spring Washer	5	41	07146-0100	Support Ring	3
12	12137	Oil Drain Plug	1	42	07147	Tension Spring	3
13	07182	Gasket	1	43	13018-5000	Valve Casing	1
14	07111	Bearing Cover	2	44A	07150	O-Ring	6
15	07112	Crankshaft Seal	2	44B	06266	Support Ring	6
16	07113	O-Ring	2	45	06078	Compression Spring	3
17	08095	HexScrew	8	46	07060-0100	Valve Assembly	6
20	07116	Taper Roller Bearing	2	46A	07064-0100	Valve Seat	6
20A	07117	Fitting Disc, 0.1mm	2	46B	07063-0100	Valve Plate	6
20B	13001	Fitting Disc, 0.15mm	3	46C	07750-0100	Valve Spring	6
21	07118	Shaft Protector	1	46D	07066	Spacer Pipe	6
22	13242	Crankshaft	1	48	06077-0100	Plug	6
23	13243	Key	1	49	07157	Stud Bolt	8
24	13340	Connecting Rod Assy.	3	49A	07158	Nut	8
24A	13277	Hex Screw	6	49B	07159	Washer	8
24B	13278	Spring Washer	6	50	07423-0100	Plug	1
25	13341	Crosshead Plunger Base Assy.	3	50A	07755-0100	Gasket	1
28	13232	Crosshead Pin	3	52	13020	Disk for Crankshaft	1
29A	07125	Centering Sleeve	3	53	06607	Hexagon Screw	1
29B	07130	Plunger Pipe	3	54	13321-0100	Plug 1" BSP	1
29C	07131-0100	Plunger Bolt	3	55	13322-0100	Plug, 1" BSP	1
29D	07161-0100	Gasket for Bolt	3				

LP121A-5100 Repair Kits

Plunger & Oil Seal Kit

09523

Item	Qty.	Part#	Description
31	3	07133	Radial Shaft Seal
36	3	13291	Grooved Ring
38	6	07140	O-Ring
39	3	07142-0100	Pressure Ring
40	6	07144	Sleeve

Valve Assembly Kit

#09524

Item	Qty.	Part #	Description
46	6	07060-0100	Valve Assembly, Com- plete
44A	9	07150	O-Ring
44B	3	06266	Support Ring



1. With a 30mm wrench, remove the six (6) plugs (48) from the valve casing (43). Inspect the o-rings (48A) and replace if necessary. Remove the complete valve assembly (46A) by threading a 12mm bolt into the spring retainer and pulling straight out.

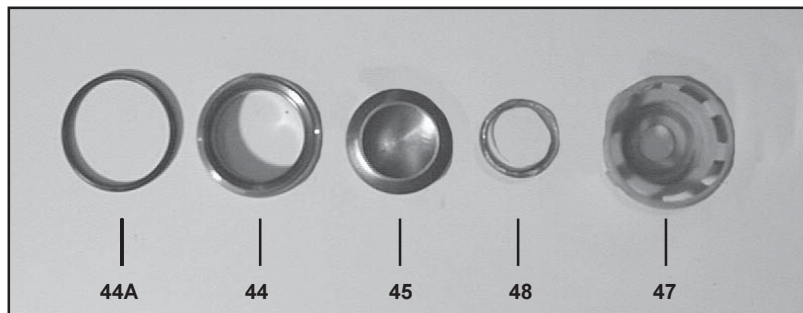

2. To disassemble the valve, screw the bolt into the retainer until the valve plate (45) presses the valve seat (44) out of the spring retainer. Examine all parts and replace if necessary. If the seat doesn't come out, use a valve puller to remove.



3. Remove the eight (8) hex nuts (49A) with a 19mm wrench. Tap the back of the manifold (43) with a rubber mallet to dislodge and slide off the studs.

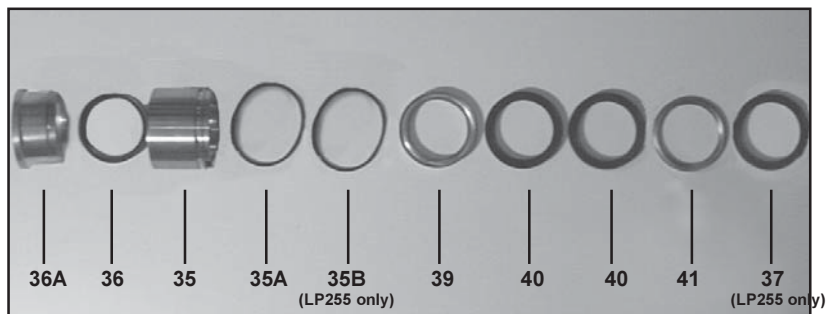

4. Remove the seal sleeve (35) from the manifold and/or crankcase. Remove the pressure rings (39&36A), v-sleeves (40&36), support ring (41) and o-rings (35A and 35B in Lp255A only) from the manifold and seal sleeve, respectively. For LP255 only, remove support ring (37). Examine seals carefully and replace if worn. Clean all parts.

5. If there are signs of oil leaking through the plunger oil seals, then replacement is necessary. For LP122A & LP122A-4000, remove the plunger pipe (29B) before inspecting oil seals (31A & 33). For the LP123 & LP122A-3100 disassemble the gear end and push out the seals from the back of the pump.

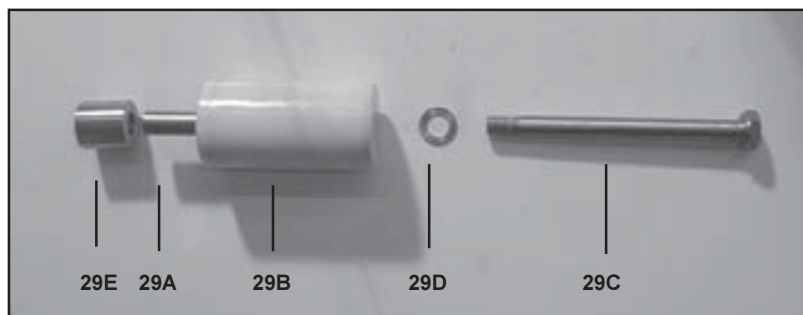

6. Inspect surface of plunger pipe (29B) carefully. Remove any chemical or mineral deposits taking care not to damage the surface of the plunger. If plunger pipe is worn, remove the plunger bolt (29C), plunger pipe (29B) and spacer (29E). Replace worn parts necessary. **Note: Always use a new copper gasket (29) when repairing the plunger assembly.**

LP122A Series/LP123/LP255 - Repair Instructions

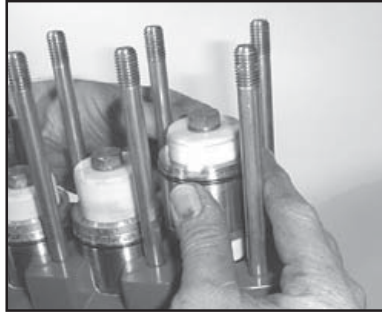

7. For LP122A & LP122A-4000 pumps, oil seal replacement can be accomplished by pulling the retainer forward out of the crankcase. The o-ring around the outside of the retainer should be replaced and lubricated with a light film of oil.

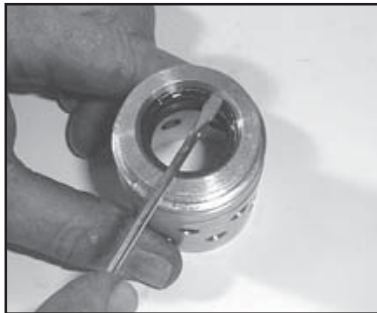

8. The back-up seal (33) can be pried out of the back of the retainer (32) with a small screwdriver. To replace with new seal, lubricate edges of new seal, then squeeze outside edges of seal, forcing the seal to collapse into a figure 8. Tuck the two outside edges of the figure 8 into the rear of the retainer, making sure that the inner lip of the seal faces the oil. The seal may now be pressed firmly into place.



9. The front oil seal (31A) can now be removed by inserting a screwdriver through the rear of the retainer and tapping the seal out through the front of the retainer. Remove any excess old loc-tite from retainer. To replace oil seal, apply a light film of loc-tite around outside edges of seal. Tap seal firmly into the retainer with a wooden dowel making certain that the spring side of the seal is installed first and that the seal sits squarely in the retainer.

TO REASSEMBLE PROCEED AS FOLLOWS:



10. For LP122A & LP122A-4000 pumps, generously lubricate the inside of the oil seals (31A & 33) and o-ring (32A). Next, place the seal retainer, complete (31) over the steel plunger base seat firmly into the crankcase. Replace the flinger (30).

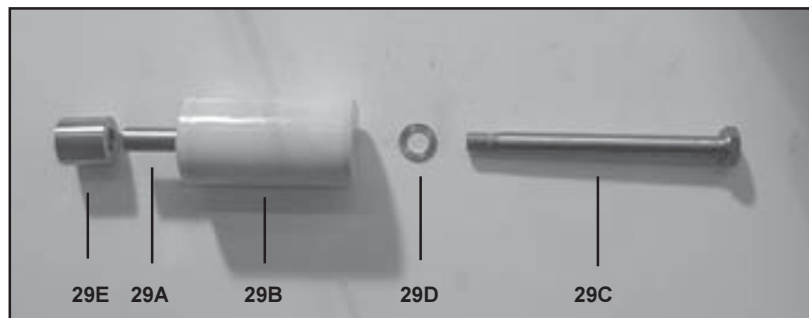

11. If previously disassembled thoroughly clean all exposed surfaces on the spacer (29E) and all exposed threads on the plunger bolt (29C) and the steel plunger base (25). Threads **MUST** be free of old loc-tite and any other material such as oil, grease, etc. This is necessary to ensure proper curing of new loc-tite. Giant recommends cleaning the threads with acetone or other suitable cleaner. Reassemble plunger assembly parts (29A, 29B, & 29E) using a new copper gasket (29D) and the cleaned plunger bolt (29C). Slide the bolt through the center of the four (4) pieces so that the threaded end is exposed. Apply several drops of loc-tite 243 (or equivalent) adhesive to the threads. Thread into steel plunger base and tighten to 26 ft.-lbs. **BE CERTAIN ALL PARTS ARE CENTERED WITH THE BOLT!**

LP122A Series/LP123/LP255 - Repair Instructions

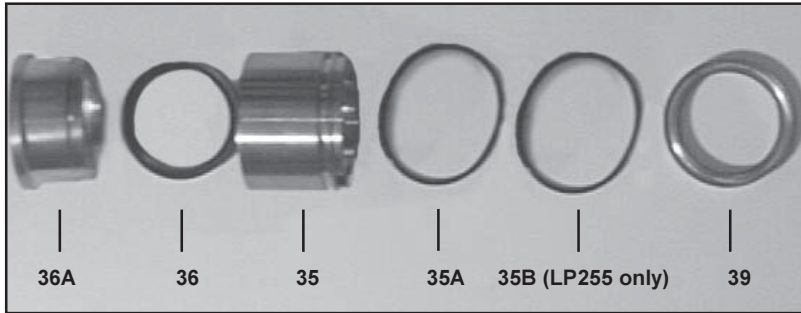

12. Lubricate weep seal (36). Place, weep seal (36), and pressure ring (36A) into the seal sleeve (35). Assemble the o-ring (35A and 35B for LP255 only) onto seal sleeve and lubricate.



13. For LP255 pumps, insert support ring (37) into valve casing (43). Place support ring (41) and v-sleeves (40) into valve casing.

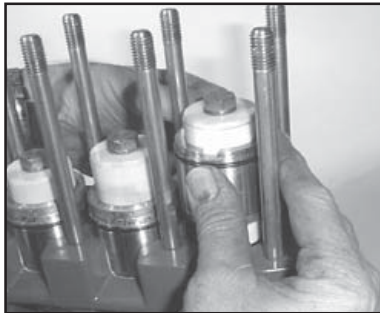

14. Press seal sleeve assembly into the manifold and seat firmly. Put the support ring (41) on plunger with v-side facing the manifold.

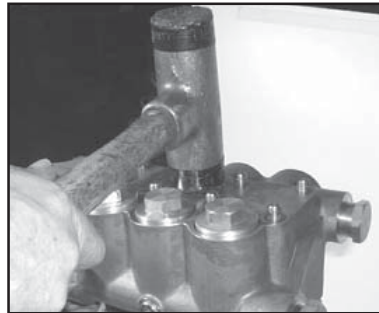

15. Place entire manifold/seal sleeve assembly over the studs and push firmly until seated against the crankcase.

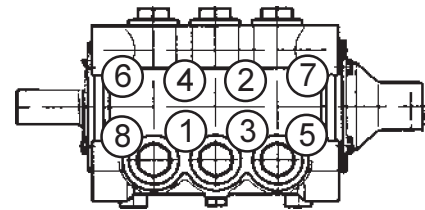

16. Tighten hex nuts (49A) in a crosswise pattern (shown above) to 60 ft.-lbs.

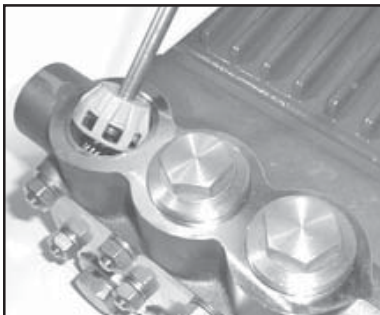

17. Next, place valve assemblies (46A) into manifold after first lubricating the o-ring (44A). Seat firmly into manifold.



18. Replace plug with o-ring (48, & 48A) and tighten to 160 ft.-lbs.

19. Fill crankcase with approximately 116 fluid ounces of Giant oil or equivalent SAE 90 industrial gear oil and check oil level of the crankcase with the dipstick. Proper level is center of two lines. Reinstall your Giant LP pump into your system.

Contact Giant Industries or your local distributor for maintenance of the gear end of your pump. Phone: 419/531-4600

Contact Giant Industries for service school information. Phone: (419) 531-4600

PUMP SYSTEM MALFUNCTION

<u>MALFUNCTION</u>	<u>CAUSE</u>	<u>REMEDY</u>
The Pressure and/ or the Delivery Drops	Worn packing seals Broken valve spring Belt slippage Worn or Damaged nozzle Fouled discharge valve Fouled inlet strainer Worn or Damaged hose Worn or Plugged relief valve on pump Cavitation Unloader	Replace packing seals Replace spring Tighten or Replace belt Replace nozzle Clean valve assembly Clean strainer Repair/Replace hose Clean, Reset, and Replace worn parts Check suction lines on inlet of pump for restrictions Check for proper operation
Water in crankcase	High humidity Worn seals	Reduce oil change interval Replace seals
Noisy Operation	Worn bearings Cavitation	Replace bearings, Refill crankcase oil with recommended lubricant Check inlet lines for restrictions and/or proper sizing
Rough/Pulsating Operation with Pressure Drop	Worn packing Inlet restriction Accumulator pressure Unloader Cavitation	Replace packing Check system for stoppage, air leaks, correctly sized inlet plumbing to pump Recharge/Replace accumulator Check for proper operation Check inlet lines for restrictions and/or proper size
Pressure Drop at Gun	Restricted discharge plumbing	Re-size discharge plumbing to flow rate of pump
Excessive Leakage	Worn plungers Worn packing/seals Excessive vacuum Cracked plungers Inlet pressure too high	Replace plungers Adjust or Replace packing seals Reduce suction vacuum Replace plungers Reduce inlet pressure
High Crankcase Temperature	Wrong Grade of oil Improper amount of oil in crankcase	Giant oil is recommended Adjust oil level to proper amount

Pump Mounting Selection Guide

Bushings 06496 - 35 mm H Bushing
Pulley & Sheaves 07165 - 12.75" Cast Iron - 4 gr. AB Section
Rails 07357 - Plated Steel Channel Rails (L=11.75"x W=1.88"x H=3.00")

LP121A-5100 TORQUE SPECIFICATIONS

<u>Position</u>	<u>Item#</u>	<u>Description</u>	<u>Torque Amount</u>
10	08093	Screw, Cover	125 in.-lbs.
17	08095	Hex Screw, Bearing Cover	125 in.-lbs.
24A	13277	Hex Screw, Connecting Rod	250 in.-lbs.
29C	07131-0100	Plunger Bolt	26 ft.-lbs.
48	06077-0100	Plug, Valve	160 ft.-lbs.
49A	07158	Nut, Stud Bolt	60 ft.-lbs.

Preventative Maintenance Check-List & Recommended Spare Parts List						
Check	Daily	Weekly	50hrs	Every 500 hrs	Every 1500 hrs	Every 3000 hrs
Oil Level/Quality	X					
Oil Leaks	X					
Water Leaks	X					
Belts, Pulley		X				
Plumbing		X				
Recommended Spare Parts						
Oil Change			X	X		
Seal Spare Parts (1 kit/pump) (See page 5 for kit list)					X	
Oil Seal Kit (1 kit/pump) (See page 5 for kit list)					X	
Valve Spare Parts (1 kit/pump) (See page 5 for kit list)						X

LP121A-5100 DIMENSIONS - INCHES (mm)

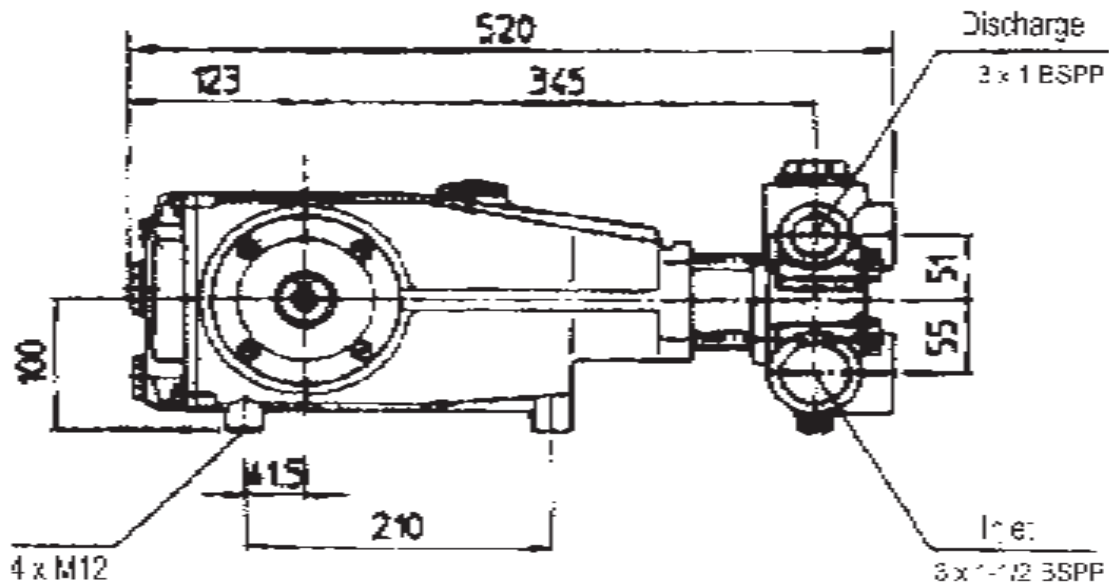
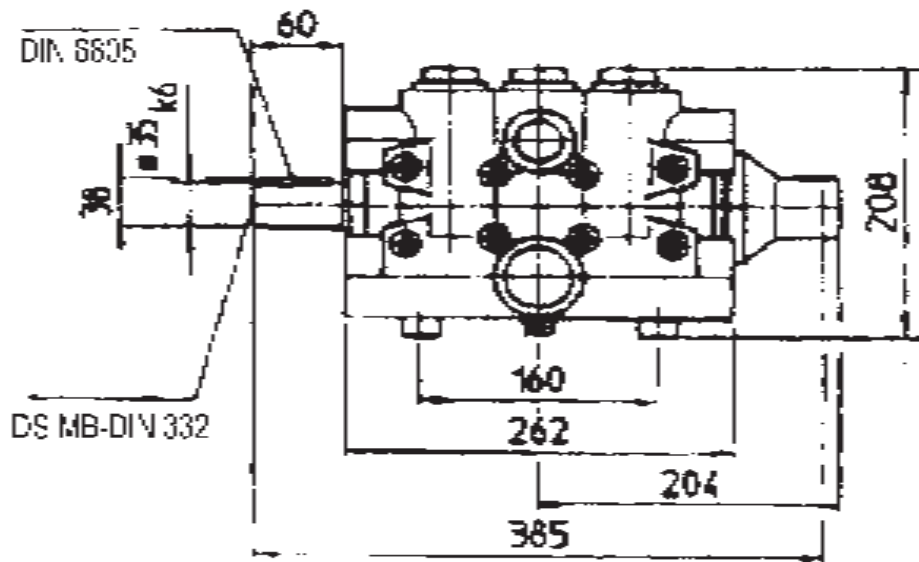

GIANT INDUSTRIES LIMITED WARRANTY

Giant Industries, Inc. pumps and accessories are warranted by the manufacturer to be free from defects in workmanship and material as follows:

1. For portable pressure washers and self-service car wash applications, the discharge manifolds will never fail, period. If they ever fail, we will replace them free of charge. Our other pump parts, used in portable pressure washers and in car wash applications, are warranted for five years from the date of shipment for all pumps used in NON-SALINE, clean water applications.
2. One (1) year from the date of shipment for all other Giant industrial and consumer pumps.
3. Six (6) months from the date of shipment for all rebuilt pumps.
4. Ninety (90) days from the date of shipment for all Giant accessories.

This warranty is limited to repair or replacement of pumps and accessories of which the manufacturer's evaluation shows were defective at the time of shipment by the manufacturer. The following items are NOT covered or will void the warranty:

1. Defects caused by negligence or fault of the buyer or third party.
2. Normal wear and tear to standard wear parts.
3. Use of repair parts other than those manufactured or authorized by Giant.
4. Improper use of the product as a component part.
5. Changes or modifications made by the customer or third party.
6. The operation of pumps and or accessories exceeding the specifications set forth in the Operations Manuals provided by Giant Industries, Inc.

Liability under this warranty is on all non-wear parts and limited to the replacement or repair of those products returned freight prepaid to Giant Industries which are deemed to be defective due to workmanship or failure of material. A Returned Goods Authorization (R.G.A.) number and completed warranty evaluation form is required prior to the return to Giant Industries of all products under warranty consideration. Call (419)-531-4600 or fax (419)-531-6836 to obtain an R.G.A. number.

Repair or replacement of defective products as provided is the sole and exclusive remedy provided hereunder and the MANUFACTURER SHALL NOT BE LIABLE FOR FURTHER LOSS, DAMAGES, OR EXPENSES, INCLUDING INCIDENTAL AND CONSEQUENTIAL DAMAGES DIRECTLY OR INDIRECTLY ARISING FROM THE SALE OR USE OF THIS PRODUCT.

THE LIMITED WARRANTY SET FORTH HEREIN IS IN LIEU OF ALL OTHER WARRANTIES OR REPRESENTATION, EXPRESS OR IMPLIED, INCLUDING WITHOUT LIMITATION ANY WARRANTIES OR MERCHANTABILITY OR FITNESS FOR A PARTICULAR PURPOSE AND ALL SUCH WARRANTIES ARE HEREBY DISCLAIMED AND EXCLUDED BY THE MANUFACTURER.



GIANT INDUSTRIES, INC., 900 N. Westwood Avenue, P.O. Box 3187, Toledo, OH 43607
PHONE: (419) 531-4600, FAX: (419) 531-6836, www.giantpumps.com
© Copyright 2002 Giant Industries, Inc.