



BD Motorized Pump Units

Motors 8023ES, 8024ES
8025ES

Used on Pump Models: 230, 231, 237
240, 241, 247
270, 271, 277

Motors 8026ES, 8027ES
8028ES, 8029ES

Used on Pump Models: 340, 341, 347
350, 351, 357

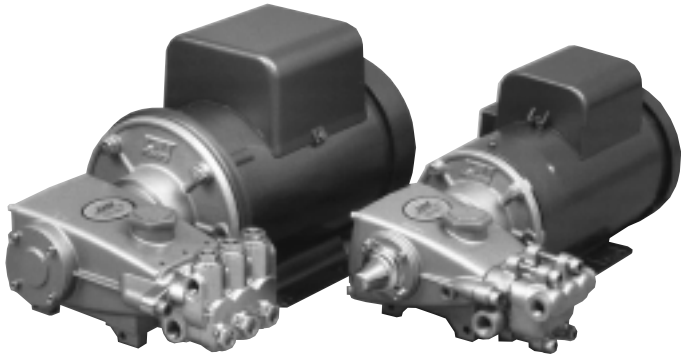

PUMP FEATURES

- Exclusive CAT PUMPS, specially formulated Hi-Pressure Seals for exceptionally long operation.
- Special concentric, high density, polished solid ceramic plungers provide a true wear surface and extended life.
- Triplex plunger design providing low pulsation and quiet operation.
- Internally lubricated and cooled packings for extended life.

MOTORIZED UNIT FEATURES

- No pulley selection
- No belt slippage and adjustment
- No bulky belt guards
- No wasted assembly time
- No multiple source purchases

INSTALLATION INSTRUCTIONS

INSTALLATION

Before installing motorized pump unit, check incoming voltage to be certain it does not exceed motor rating as this will result in motor damage. Instructions for electrical connection are on a decal on the motor housing.

Qualified or trained personnel should install equipment. Equipment should be installed in accordance with the National Electrical Code, local codes and with NEMA MG1, Safety Standards for Construction and Guide for Selection, Installation and Use of Electric Motors and Generators.

Review your application flow and pressure requirements. Exceeding the rated pressure of the motorized unit may cause overheating of your motor, high amp draw and result in shortened motor life. Before operation see lubrication on next page.

CAUTION

Some Motor Models Contain No Thermal Protector

A separate overcurrent protection device must be installed to prevent motor burnout and possible fire damage due to overloaded or stalled motor. Motor must be properly grounded.

WARNING

All systems require both a primary pressure regulating device (i.e., regulator, unloader) and a secondary pressure safety relief device (i.e., pop-off valve, safety valve). Failure to install such relief devices could result in personal injury or damage to the pump or to system components. CAT PUMPS does not assume any liability or responsibility for the operation of a customer's high pressure system.

ASSEMBLY OF ELECTRIC MOTOR AND PUMP

- A flange mount is required to mount the electric motor to the pump.
- Rotate pump shaft so keyway is toward back of pump. **Insert key into pump shaft. To assure key is completely seated, BEVELED END SHOULD BE TOWARD PUMP AND FLAT SURFACE HORIZONTAL WITH SHAFT KEYWAY.** Shaft may not fit into motor if key is improperly installed.
- Next slip washers onto **shaft retaining bolt (M8x20)**. Apply Loctite® 242® to threaded section and thread bolt into pump shaft. Torque to 110 in. lbs. (12 Nm) (Models 340 and 350 only.)
NOTE: Follow application instructions on Loctite® container.
- **Mount adapter plate onto pump with extended collar toward pump, side vents to the right and left.** Line up center four threaded holes with those on bearing case.
- Apply a small amount of Loctite® 242® to the four M6x20 Hex Flat Head screws and secure adapter plate to pump. Torque to 60-70 in. lbs. (6-8 Nm).
- Apply Loctite® 242® to set screws and insert into motor shaft. **Thread into shaft only partially—not completely into keyway.**

(continued next page)

Loctite and 242 are registered trademarks of the Henkel Corporation.

“Customer confidence is our greatest asset”

3 FRAME — Motorized Pump Units

MOTORIZED UNITS

Shipping Unit Weight.....
Shipping Unit Dimensions

	230BD151	230BD31	230BD33
	231BD151	231BD31	231BD33
	237BD151	237BD31	237BD33
	76 lbs.	110 lbs.	90 lbs.
	26.5" x 16.5" x 16.0"	26.5" x 16.5" x 16.0"	26.5" x 16.5" x 16.0"

PUMPS

Flow.....
Discharge Pressure.....
Maximum Inlet Pressure

	230, 231, 237	230, 231, 237	230, 231, 237
	2.3 GPM	2.3 GPM	2.3 GPM
	100 to 900 PSI	100 to 1500 PSI	100 to 1500 PSI
	Flooded to 60 PSI	Flooded to 60 PSI	Flooded to 60 PSI
	1725 RPM	1725 RPM	1725 RPM

MOTORS

Flange Mount — REQUIRED.....
Horsepower.....
Phase.....
Frame Size.....
Hertz.....
Volts.....
Maximum Amps.....
Service Factor.....
Maximum Ambient Temperature.....
Shaft Diameter (Hollow).....
Thermo Overload.....
Capacitor Start.....
Insulation.....
CSA Reference No.
U.L. Reference No.

	8023ES	8024ES	8025ES
	8020	8021	8021
	1.5 HP	3.0 HP	3.0 HP
	Single	Single	Three
	56C-TEFC	184TC-TEFC	182TC-TEFC
	60 HZ	60 HZ	60 HZ
	115/208/230V	230V	208-230/460V
	12.8/6.7/6.4 Amps	13.2 Amps	9.0/8.6/4.3 Amps
	1.15	1.0	1.15
	104°F	104°F	104°F
	16.5 mm	16.5 mm	16.5 mm
	No	Yes	No
	Yes	Yes	No
	Class B	Class F	Class F
	LR-2262	LR-2262	LR-2262
	E-46145	E-46145	E-46145

MOTORIZED UNITS

Shipping Unit Weight.....
Shipping Unit Dimensions

	240BD31	240BD33	270BD31	270BD33
	241BD31	241BD33	271BD31	271BD33
	247BD31	247BD33	277BD31	277BD33
	110 lbs.	90 lbs.	110 lbs.	90 lbs.
	26.5" x 16.5" x 16.0"	26.5" x 16.5" x 16.0"	26.5" x 16.5" x 16.0"	26.5" x 16.5" x 16.0"

PUMPS

Flow.....
Discharge Pressure.....
Maximum Inlet Pressure

	240, 241, 247	240, 241, 247	270, 271, 277	270, 271, 277
	3.6 GPM	3.6 GPM	4.2 GPM	4.2 GPM
	100 to 1200 PSI	100 to 1200 PSI	100 to 1000 PSI	100 to 1000 PSI
	Flooded to 60 PSI	Flooded to 60 PSI	Flooded to 60 PSI	Flooded to 60 PSI
	1725 RPM	1725 RPM	1725 RPM	1725 RPM

MOTORS

Flange Mount — REQUIRED.....
Horsepower.....
Phase.....
Frame Size.....
Hertz.....
Volts.....
Maximum Amps.....
Service Factor.....
Maximum Ambient Temperature.....
Shaft Diameter (Hollow).....
Thermo Overload.....
Capacitor Start.....
Insulation.....
CSA Reference No.
U.L. Reference No.

	8024ES	8025ES	8024ES	8025ES
	8021	8021	8021	8021
	3.0 HP	3.0 HP	3.0 HP	3.0 HP
	Single	Three	Single	Three
	184TC-TEFC	182TC-TEFC	184TC-TEFC	182TC-TEFC
	60 HZ	60 HZ	60 HZ	60 HZ
	230V	208-230/460V	230V	208-230/460V
	13.2 Amps	9.0/8.6/4.3 Amps	13.2 Amps	9.0/8.6/4.3 Amps
	1.0	1.15	1.0	1.15
	104°F	104°F	104°F	104°F
	16.5 mm	16.5 mm	16.5 mm	16.5 mm
	Yes	No	Yes	No
	Yes	No	Yes	No
	Class F	Class F	Class F	Class F
	LR-2262	LR-2262	LR-2262	LR-2262
	E-46145	E-46145	E-46145	E-46145

Refer to individual Pump Op and Service Manual for maintenance parts, service procedures and additional specifications.

[All Motors are available in 50 HZ, 1450 RPM]

- Apply **Antiseize lubricant (PN 6106)** to pump shaft and I.D. of motor shaft. Carefully insert pump into hollow motor shaft until flange is flush with motor. **Be certain key on pump shaft lines up with keyway on motor shaft.**
- Secure pump and motor with lockwasher and hex head screws and torque to 50-60 ft. lbs. (67-82 Nm).
- Using allen T-wrench (PN 34030) secure set screws through side vent in flange mount. Torque to 60-75 in. lbs. (7-8 Nm).

8020 Flange Mount (8023ES)

- 1 34110 Flange
- 2 34162 Screw, HHC (10-32x1/2)
- 4 34379 Screw, HH (M6x20)
- 4 34160 Screw, HH (3/8"x1-1/4")
- 4 126745 R Lockwasher (M6)
- 1 32145 Screw, Assy HH (M8x20)
- 4 30921 R Lockwasher (3/8")
- 1 30047 Key
- 1 6106 Antiseize

8021 Flange Mount (8024ES, 8025ES)

- 1 34111 Flange
- 2 34162 Screw, HHC (10-32x1/2)
- 4 34379 Screw, HH (M6x20)
- 4 32143 Screw, HH (1/2"x1-1/4")
- 4 126745 R Lockwasher (M6)
- 1 32145 Screw, Assy HH (M8x20)
- 4 30908 Lockwasher (1/2")
- 1 30047 Key
- 1 6106 Antiseize

8022 Flange Mount (8026ES, 8027ES, 8028ES, 8029ES)

- 1 34112 Flange
- 2 34162 Screw, HHC (10-32x1/2)
- 4 34379 Screw, HH (M6x20)
- 4 32143 Screw, HH (1/2"x1-1/4")
- 4 126745 R Lockwasher (M6)
- 1 32145 Screw, Assy HH (M8x20)
- 4 30908 Lockwasher (1/2")
- 1 30057 Key
- 1 6106 Antiseize

R Components comply with RoHS Directive.

5 FRAME — Motorized Pump Units

MOTORIZED UNITS	340BD31 341BD31 347BD31	340BD33 341BD33 347BD33	340BD51 341BD51 347BD51	340BD53 341BD53 347BD53
Shipping Unit Weight.....	122 lbs.	98 lbs.	128 lbs.	112 lbs.
Shipping Unit Dimensions	26.5" x 16.5" x 16.0"	26.5" x 16.5" x 16.0"	26.5" x 16.5" x 16.0"	26.5" x 16.5" x 16.0"
PUMPS	340, 341, 347	340, 341, 347	340, 341, 347	340, 341, 347
Flow.....	4.0 GPM	4.0 GPM	4.0 GPM	4.0 GPM
Discharge Pressure.....	100 to 1100 PSI	100 to 1100 PSI	100 to 1800 PSI	100 to 1800 PSI
Maximum Inlet Pressure	Flooded to 60 PSI	Flooded to 60 PSI	Flooded to 60 PSI	Flooded to 60 PSI
RPM	1725 RPM	1725 RPM	1725 RPM	1725 RPM
MOTORS	8026ES	8027ES	8028ES	8029ES
Flange Mount — REQUIRED.....	8022	8022	8022	8022
Horsepower.....	3.0 HP	3.0 HP	5.0 HP	5.0 HP
Phase	Single	Three	Single	Three
Frame Size	184TC-TEFC	182TC-TEFC	184TC-TEFC	184TC-TEFC
Hertz.....	60 HZ	60 HZ	60 HZ	60 HZ
Volts	230V	208-230/460V	208-230V	208-230/460V
Maximum Amps	13.2 Amps	9.0/8.6/4.3 Amps	24.0/26.0 Amps	15.0/13.2/6.6 Amps
Service Factor	1.0	1.15	1.0	1.0
Maximum Ambient Temperature.....	104°F	104°F	104°F	104°F
Shaft Diameter (Hollow)	20 mm	20 mm	20 mm	20mm
Thermo Overload	Yes	No	No	No
Capacitor Start	Yes	N/A	Yes	N/A
Insulation	Class F	Class F	Class F	Class F
CSA Reference No.	LR-2262	LR-2262	LR-2262	LR-2262
U.L. Reference No.	E-46145	E-46145	E-46145	E-46145

MOTORIZED UNITS	350BD31 351BD31 357BD31	350BD33 351BD33 357BD33	350BD51 351BD51 357BD51	350BD53 351BD53 357BD53
Shipping Unit Weight.....	122 lbs.	98 lbs.	128 lbs.	112 lbs.
Shipping Unit Dimensions	26.5" x 16.5" x 16.0"	26.5" x 16.5" x 16.0"	26.5" x 16.5" x 16.0"	26.5" x 16.5" x 16.0"
PUMPS	350, 351, 357	350, 351, 357	350, 351, 357	350, 351, 357
Flow.....	5.0 GPM	5.0 GPM	5.0 GPM	5.0 GPM
Discharge Pressure.....	100 to 900 PSI	100 to 900 PSI	100 to 1450 PSI	100 to 1450 PSI
Maximum Inlet Pressure	Flooded to 60 PSI	Flooded to 60 PSI	Flooded to 60 PSI	Flooded to 60 PSI
RPM	1725 RPM	1725 RPM	1725 RPM	1725 RPM
MOTORS	8026ES	8027ES	8028ES	8029ES
Flange Mount — REQUIRED.....	8022	8022	8022	8022
Horsepower.....	3.0 HP	3.0 HP	5.0 HP	5.0 HP
Phase	Single	Three	Single	Three
Frame Size	184TC-TEFC	182TC-TEFC	184TC-TEFC	184TC-TEFC
Hertz.....	60 HZ	60 HZ	60 HZ	60 HZ
Volts	230V	208-230/460V	208-230V	208-230/460V
Maximum Amps	13.2 Amps	9.0/8.6/4.3 Amps	24.0/26.0 Amps	15.0/13.2/6.6 Amps
Service Factor	1.0	1.15	1.0	1.0
Maximum Ambient Temperature.....	104°F	104°F	104°F	104°F
Shaft Diameter (Hollow)	20 mm	20 mm	20 mm	20mm
Thermo Overload	Yes	No	No	No
Capacitor Start	Yes	N/A	Yes	N/A
Insulation	Class F	Class F	Class F	Class F
CSA Reference No.	LR-2262	LR-2262	LR-2262	LR-2262
U.L. Reference No.	E-46145	E-46145	E-46145	E-46145

Refer to individual Pump Op and Service Manual for maintenance parts, service procedures and additional specifications.

[All Motors are available in 50 HZ, 1450 RPM]

WARRANTY

All electric motors are warranted by the manufacture to be free from defects of material and workmanship for **one year from date of shipment**.

For warranty consideration, ship the defective motor PREPAID directly to Baldor. Contact CAT PUMPS for warranty procedure and the nearest authorized Baldor Service Center.

If you are uncertain as to the cause of failure (Pump or Motor) return the complete assembly PREPAID to CAT PUMPS for evaluation. **Call for RGA number prior to returning.**

See individual Pump Service Manual for pump warranty.

PUMP LUBRICATION

Before starting pump, fill crankcase per specifications with CAT PUMPS special custom-blend, multi-viscosity, ISO-68 petroleum based hydraulic oil with anti-wear, oxidizer, high pressure and rust inhibitor additives. Change initial fill after 50 hours running period. Change oil every 3 months or at 500 hour intervals thereafter.

MOTOR LUBRICATION

This is a ball bearing motor. The bearings have been given initial lubrication at the factory. No lubricant need be added unless motor has been stored for over a year.

(continued on back)

Baldor motors are pre-greased normally with Shell Oil Company's "Dolium R". Several equivalent greases which are compatible with Baldor furnished grease are Chevron Oil's "SRI No. 2" and Texaco Inc. "Premium RB".

Overgreasing bearings can cause premature failure. Motor is equipped with Alemite fitting. Clean tip of fitting and apply grease gun. Use 1 to 2 strokes. Any excess may drip out the bottom drain during the first 20 minutes of operation.

CAUTION

Keep grease clean. Lubricate motors at standstill. Remove and replace drain plugs at standstill. Do not mix petroleum grease and silicone grease in motor bearings.

Suggested Relube Interval

Hours of Service Per Year	NEMA Frame Size 184TCZ
500 Hours	5 Years
Continuous Normal Application	2 Years
Seasonal Service Motor is idle for 6 months or more	1 Year (beginning of season)
Continuous high ambients, dirty or moist locations, high vibration, or shaft end is hot (pump fans)	6 months

DIMENSIONAL

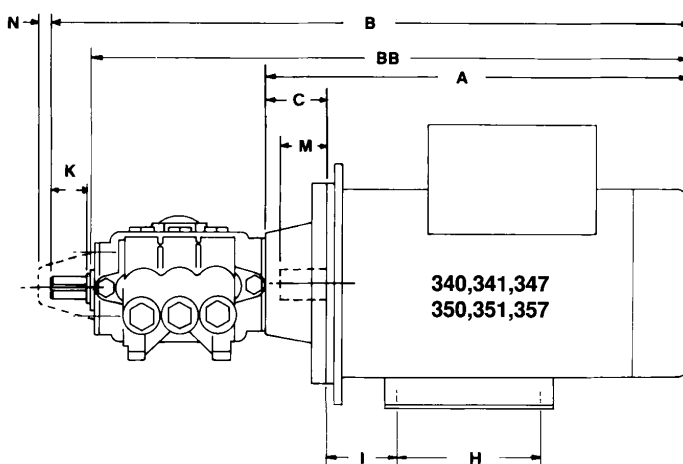
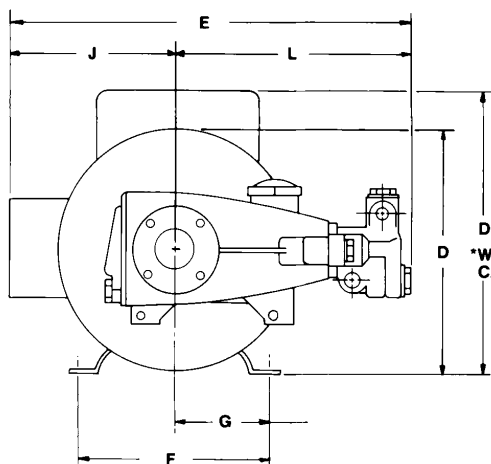
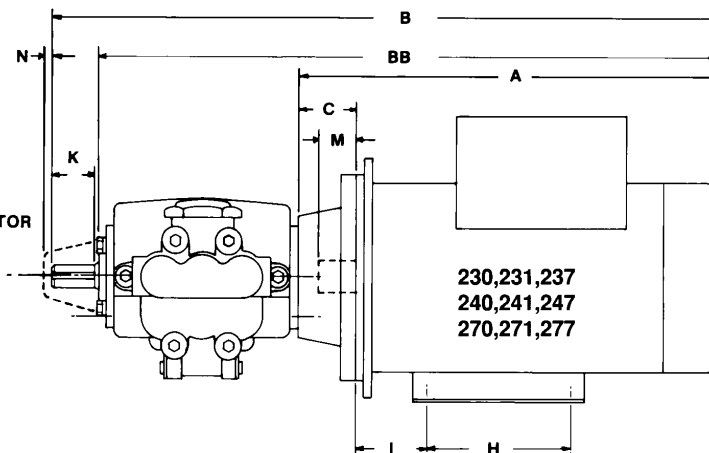
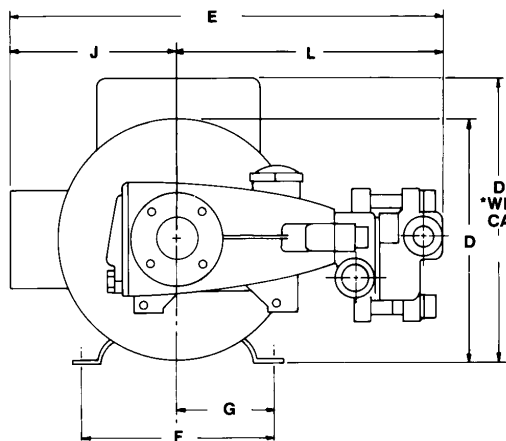

MOTOR	PUMP	A	B	BB	C	D	E	F	G	H	I	J	K	L	M	N
8023ES (1.5 hp 1 ph)	(16.5mm) 3PFR	14.62 (371)	21.82 (554)	—	2.00 (50)	*8.38 (213)	12.85 (326)	4.88 (124)	2.44 (62)	3.0 (76)	3.06 (78)	5.25 (133)	1.30 (33)	7.6 (193)	1.47 (37)	.30 (7.6)
8024ES (3 hp 1 ph)	(16.5mm) 3PFR	15.82 (402)	23.02 (585)	—	1.88 (48)	*11.56 (294)	14.10 (358)	7.50 (190)	3.75 (95)	5.5 (140)	3.62 (92)	6.5 (165)	1.30 (33)	7.6 (193)	1.47 (37)	.30 (7.6)
8025ES (3 hp 3 ph)	(16.5mm) 3PFR	15.91 (404)	23.11 (587)	—	1.88 (48)	9.00 (229)	13.48 (342)	7.50 (190)	3.75 (95)	5.5 (140)	3.62 (92)	5.88 (149)	1.30 (33)	7.6 (193)	1.47 (37)	.30 (7.6)
8026ES (3 hp 1 ph)	(20mm) 5PFR	15.82 (402)	24.09 (612)	22.49 (571)	1.88 (48)	*11.56 (294)	15.43 (392)	7.50 (190)	3.75 (95)	5.5 (140)	3.62 (92)	6.5 (165)	1.46 (37)	8.93 (227)	1.47 (37)	.13 (3.3)
8027ES (3 hp 3 ph)	(20mm) 5PFR	15.91 (404)	24.18 (614)	22.58 (574)	1.88 (48)	9.00 (229)	14.81 (376)	7.50 (190)	3.75 (95)	5.5 (140)	3.62 (92)	5.88 (149)	1.46 (37)	8.93 (227)	1.47 (37)	.13 (3.3)
8028ES (5 hp 1 ph)	(20mm) 5PFR	17.32 (440)	25.59 (650)	23.99 (609)	1.88 (48)	*11.56 (294)	14.81 (376)	7.50 (190)	3.75 (95)	5.5 (140)	3.62 (92)	5.88 (149)	1.46 (37)	8.93 (227)	1.47 (37)	.13 (3.3)
8029ES (5 hp 3 ph)	(20mm) 5PFR	17.29 (439)	25.56 (649)	23.96 (608)	1.88 (48)	9.00 (229)	14.81 (376)	7.50 (190)	3.75 (95)	5.5 (140)	3.62 (92)	5.88 (149)	1.46 (37)	8.93 (227)	1.47 (37)	.13 (3.3)

World Headquarters

CAT PUMPS

1681 - 94th Lane N.E. Minneapolis, MN 55449-4324

Phone (763) 780-5440 — FAX (763) 780-2958

e-mail: techsupport@catpumps.com

www.catpumps.com

International Inquiries

FAX (763) 785-4329

e-mail: intlsales@catpumps.com



The Pumps with Nine Lives

CAT PUMPS (U.K.) LTD.

1 Fleet Business Park, Sandy Lane, Church Crookham

FLEET, Hampshire, GU52 8BF, England

Phone Fleet 44 1252-622031 — Fax 44 1252-626655

e-mail: sales@catpumps.co.uk

N.V. CAT PUMPS INTERNATIONAL S.A.

Heiveldkens 6A, B-2550 Kontich, Belgium

Phone 32-3-450.71.50 — Fax 32-3-450.71.51

e-mail: cpi@catpumps.be www.catpumps.be

CAT PUMPS DEUTSCHLAND GmbH

Buchwiese 2, D-65510 Idstein, Germany

Phone 49 6126-9303 0 — Fax 49 6126-9303 33

e-mail: catpumps@t-online.de www.catpumps.de