



**Pressure Sensitive
High Flow
Regulating Unloader**

Model 9900

FEATURES

- Maintains full system pressure while running in by-pass without full load on pump.
- Offers pump protection against pressure fluctuations and system changes.
- Easy external pressure adjustment with locking nut to prevent pump over pressure.
- Flow through design for convenient in-line mounting.
- Optional remote mounting feature.

SPECIFICATIONS

	U.S. Measure	Metric Measure
Flow Range	50-120 GPM	(189-450 L/M)
Pressure Range	100-2900 PSI	(7-200 BAR)
Maximum Temperature	140°F	(60°C)
Inlet Port (Back)	1-1/4" NPTF	(1-1/4" NPTF)
Discharge Port (Front)	1-1/4" NPTF	(1-1/4" NPTF)
By-Pass Port (Bottom)	1-1/2" NPTF	(1-1/2" NPTF)
Weight	13.12 lbs.	(5.95 kg)
Dimensions	12.51 x 6.66 x 2.50"	(318x 169x 63.5 mm)

Unloader is stamped with a European safety pressure. Use only at above specifications to assure proper unloader life and performance.

For relief valve version add .100 to unloader model number.

⚠ WARNING

All systems require both a primary pressure regulating device (i.e., regulator, unloader) and a secondary pressure safety relief device (i.e., pop-off valve, safety valve). Failure to install such relief devices could result in personal injury or damage to the pump or to system components. CAT PUMPS does not assume any liability or responsibility for the operation of a customer's high pressure system.

90 DAY WARRANTY

Refer to complete CAT PUMPS Warranty for further information.

“Customer confidence is our greatest asset”

SELECTION

This is a pressure sensitive regulating unloader. Designed for systems with single or multiple pumps, solenoid (gate) valves, nozzles, standard or "weep" guns.

Note: For multiple pump systems, it is best to use a pressure regulator not a pressure sensitive regulating unloader.

This pressure sensitive regulating unloader should meet both the desired system flow (combined nozzle flow rate requirement) and the desired system pressure.

Note: Operation below the minimum flow of the unloader causes the unloader to cycle. Operation above the maximum flows of the unloader causes premature unloader wear, cycling and prevents attaining desired system pressure.

INSTALLATION

This unloader operates properly when mounted in any direction, however, it is preferred to keep the plumbing to a minimum and the pressure adjuster handle easily accessible. The best mounting location is directly on the pump discharge manifold head.

The inlet connection on this unloader is a 1-1/4" NPTF sized port and is located on the back side. There is an arrow and the word IN cast into the body indicating the direction of flow. Fluid from the discharge of the manifold goes through this connection.

The discharge connection on this unloader is a 1-1/4" NPTF sized port and is located on the front side (hex end). There is an arrow and the word OUT cast into the body indicating the direction of flow. Plumbing for the spray guns, solenoid (gate) valves or nozzles are connected here.

The by-pass connection of this unloader is a 1-1/2" NPTF sized port and is located on the bottom. There is an arrow and the word BY-PASS cast into the body indicating the direction of flow. By-Pass fluid is directed out of this port and can be routed to a reservoir (preferred method), or to a drain or to the pump inlet.

OPERATION

This pressure sensitive regulating unloader holds established system pressure in the discharge line when the trigger gun is closed or solenoid (gate) valve is closed or the nozzle is clogged, thus by-passing all unrequired flow. Squeezing the trigger gun or opening the solenoid (gate) valve will close off the by-pass and return to established system pressure without delay.

PRESSURE ADJUSTMENT

Pressure Adjustment as an Unloader

1. Setting and adjusting the unloader pressure must be done with the system "on".
2. Start the system with unloader backed off to the lowest pressure setting (counterclockwise direction).
3. Squeeze the trigger and read the pressure on the gauge at the pump.

Note: Do not read the pressure at the gun or nozzle.

4. If more pressure is desired, release the trigger, turn pressure adjuster one quarter turn in clockwise direction.
5. Squeeze the trigger and read the pressure.
6. Repeat this process until desired system pressure is attained.
7. Once the desired system pressure is reached, stop turning the pressure adjuster.
8. Thread locking nut up to pressure adjuster.

Note: Locking nut is not set at the factory.

CAUTION: A minimum by-pass flow of 5% of the unloader rated flow capacity is required for proper unloader performance. If the entire out is directed through the unloader (zero by-pass) the "cushioning" feature of the by-pass liquid is eliminated and the unloader can malfunction or wear prematurely.

9. If desired system pressure cannot be reached, review TROUBLESHOOTING chart.
10. When servicing existing systems, back locking nut away from pressure adjuster.
11. Follow adjustment procedures as stated above for new unloaders.

Note: Do not adjust unloader pressure setting to compensate for a worn nozzle. Check the nozzle as part of the regular maintenance and replace if worn.

Pressure Adjustment as a Relief Valve

1. Remove hex discharge fitting, spring and check valve from discharge port.
2. Reinstall hex discharge fitting into discharge port.
3. Turn pressure adjuster on the top of the relief valve in a counterclockwise direction in small increments until there is some visible fluid coming out of the by-pass port.
4. Turn pressure adjuster in a clockwise direction until visible fluid stops coming out.
5. Final adjustment for the relief valve should relieve at 200 PSI above the operating system.

TYPICAL UNLOADER INSTALLATION

- 1 Pressure Gauge
- 2 Relief Valve
Show as a secondary safety relief valve
- 3 Pulsation Dampener
- 4 Pressure Sensitive Regulating Unloader
- 5 Triplex Plunger Pump with Rails
- 6 C.A.T. (Captive Acceleration Tube) Not Shown
Recommended for Industrial Applications

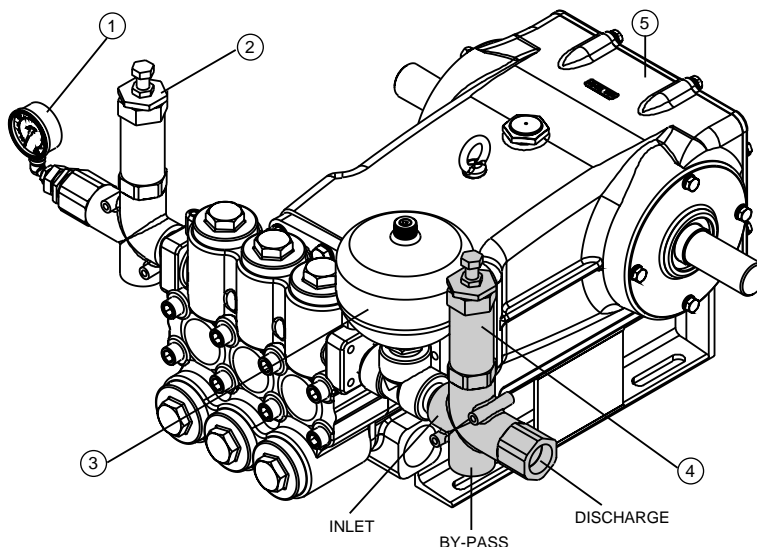

SERVICING

CAUTION: Before commencing with service, shut off drive (electric motor, gas or diesel engine) and turn off water supply to pump. Relieve all discharge line pressure by triggering gun or opening valve in discharge line.

Disassembly

1. Disconnect by-pass and discharge plumbing from unloader.
2. Remove unloader from pump.
3. Secure unloader in a vise. Use a wrench to remove brass spring retainer.
4. Remove upper spring retainer and spring from upper body. Examine spring for fatigue or breaks and replace as needed.
5. Using the same wrench, unthread upper body from lower body. Remove upper body and lower spring retainer.
6. Remove piston stem and valve assembly which includes the upper and lower piston retainers from lower body. Seat will remain in lower body.
7. Secure valve with pliers on flat surfaces and then place a M10 allen wrench into hex head of piston stem. Remove valve from piston stem.

CAUTION: Exercise extreme caution to avoid contact and damage to the tapered surface of the valve.

8. Place piston stem with hex hole down on work surface.
9. Remove lower piston retainer with o-rings and back-up-ring. Examine outside diameter o-ring and inside diameter o-ring with back-up-ring for cuts or wear and replace as needed.
10. Remove upper piston retainer with o-rings and back-up-ring. Examine outside diameter o-ring and inside diameter o-ring with back-up-ring for cuts or wear and replace as needed.
11. Examine large and small outside diameter surfaces of the piston stem for scratches or nicks and replace as needed.
12. Examine seat in lower body for scoring or wear and replace as needed.
13. Remove discharge fitting with o-ring, spring, check valve and o-ring. Examine check valve and spring for fatigue and wear and replace as needed. Examine o-rings for cuts or wear and replace as needed.

Note: While the discharge fitting is removed, inspect sealing area where the check valve makes contact within the internal body of the unloader for grooves, pitting and wear. If damage is found, stop the repair and replace with complete new unloader. If not, proceed with reassembly.

Reassembly

1. Place spring inside check valve. Lubricate and install o-ring on outside diameter of check valve. Install check valve assembly into discharge port of lower body of unloader.
2. Apply Loctite® 242® to threads of discharge fitting. Thread discharge fitting into body of unloader.
3. Lubricate and install o-ring onto seat. Press seat into unloader lower body.
4. Place piston stem with hex hole down on work surface.
5. Lubricate and install small o-ring inside upper piston retainer, then place back-up-ring on top of o-ring. Lubricate and install larger o-ring around the outside diameter of upper piston retainer.
6. Place upper piston retainer with back-up-ring facing downwards over piston stem.
7. Install back-up-ring inside lower piston retainer, then lubricate and install o-ring on top of back-up-ring. Lubricate and install larger o-ring around outside diameter of lower piston retainer.
8. Place lower piston retainer with o-ring facing down over piston stem and press against the upper piston retainer.
9. Apply Loctite® 242® to threads of piston stem and screw valve onto piston stem.
10. Lower complete piston stem and valve assembly into unloader chamber with valve facing down and hex head of piston stem facing up. Press until piston stem head is below lower body surface.
11. Thread upper body into lower body.
12. Place lower spring retainer with stainless steel ball down and small diameter guide facing up into the upper body.
13. Install spring onto lower spring retainer.
14. Place upper spring retainer on top of spring with small diameter guide facing down.
15. Thread on spring retainer to upper body. Do not tighten pressure adjuster at this time.
16. Re-install unloader onto pump.
17. Reconnect by-pass and discharge plumbing to unloader.
18. To set system pressure as an unloader or relief valve see **PRESSURE ADJUSTMENT**.

Loctite® 242® are registered trademarks of the Henkel Corporation.

TROUBLESHOOTING

Unloader cycles	<ul style="list-style-type: none"> ● Check for leak downstream of unloader. ● Worn O-Ring or check valve. ● Air in system, poor connection. ● O-Ring in gun worn. ● Insufficient flow through unloader.
Liquid leaking from bottom fitting	<ul style="list-style-type: none"> ● O-Ring for fitting cut or worn. ● O-Ring for seat cut or worn.
Liquid leaking from middle	<ul style="list-style-type: none"> ● O-Ring for piston worn or cut. ● O-Rings for piston stem worn or cut.
Unloader will not come up to pressure	<ul style="list-style-type: none"> ● Not properly sized for system pressure. ● Foreign material in unloader. Clean filter. ● Piston stem O-Rings worn. ● Nozzle worn. ● Insufficient flow to pump.
Extreme pressure spikes	<ul style="list-style-type: none"> ● Pressure adjuster/adjusting handle turned completely into unloader. ● Restricted by-pass or no by-pass.
Filtration	<ul style="list-style-type: none"> ● System flow exceeds unloader rating. ● Clean filter on regular schedule to avoid cavitation.

Approximate Pressure Reading at Gauge	Gauge Between Pump/Unloader	Gauge Between Unloader/Gun-Nozzle-Valve
System in operation (gun open)	system pressure	system pressure
System in by-pass (all guns, valves closed)	low pressure 0-150 PSI	system pressure +200 PSI

EXPLODED VIEW

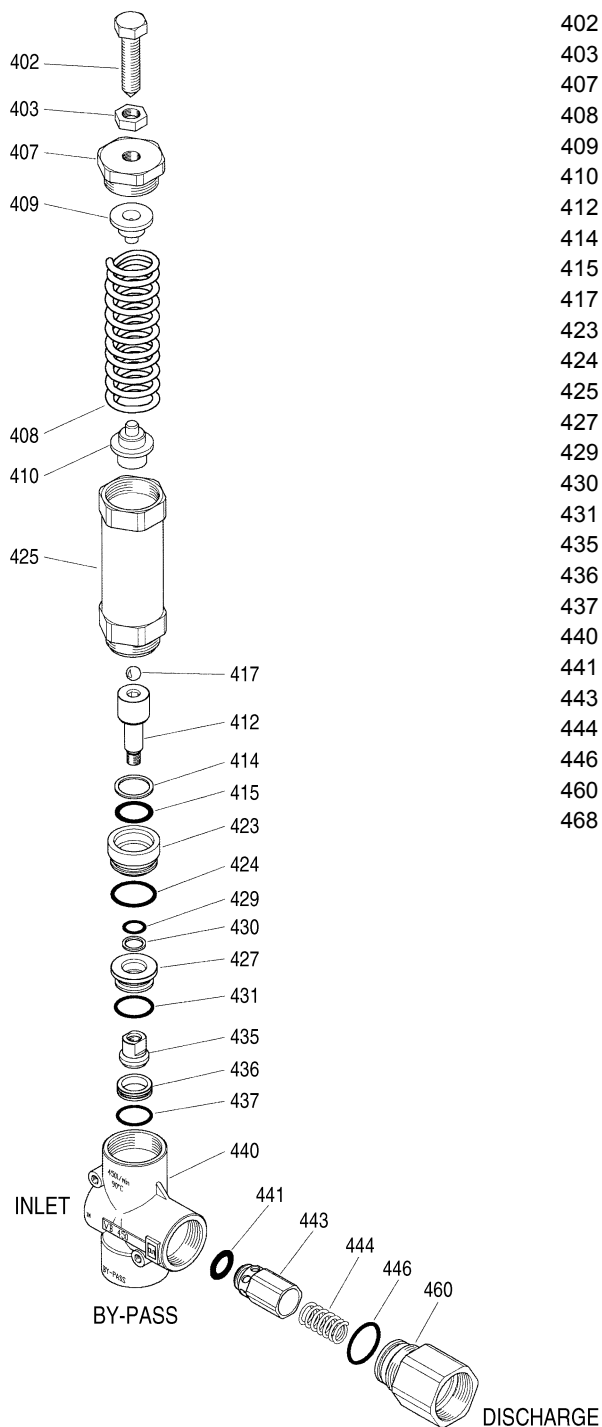

PARTS LIST

ITEM	P/N	MATL	DESCRIPTION	QTY
402	76101	S	Adjuster, Pressure (M16x54)	1
403	76121	S	Nut, Hex Locking (M16)	1
407	76122	BB	Retainer, Spring	1
408	76220	STL	Spring	1
409	76131	BB	Retainer, Spring, Upper	1
410	76132	BB	Retainer, Spring, Lower	1
412	76425	S	Stem, Piston	1
414	31882	PTFE	Back-up-Ring, Piston Stem	1
415	—	NBR	O-Ring, Piston Stem	1
417	76550	SSS	Ball	1
423	76635	BB	Retainer, Upper Piston	1
424	—	NBR	O-Ring, Upper Piston Retainer - 85D	1
425	—	BB	Body, Upper	1
427	76625	BB	Retainer, Lower Piston	1
429	—	NBR	O-Ring, Piston Stem	1
430	31834	PTFE	Back-up-Ring, Piston Stem	1
431	—	NBR	O-Ring, Lower Piston Retainer - 85D	1
435	76190	SSS	Valve	1
436	76455	SSS	Seat	1
437	—	NBR	O-Ring, Seat - 85D	1
440	—	BB	Body, Lower	1
441	—	NBR	O-Ring, Check Valve	1
443	76311	BB	Valve, Check	1
444	76230	SS	Spring	1
446	—	NBR	O-Ring, Discharge Fitting - 85D	1
460	76290	BB	Fitting, Discharge (1-1/4" NPTF)	1
468	31889	NBR	Kit, O-Ring	1

(Incls: 414,415,424,429,430,431,437,446)

Italics are optional items.

MATERIAL CODES (Not Part of Part Number):

BB=Brass NBR=Medium Nitrile (Buna-N) S=304SS SS=316SS
SSS=416S STL=Steel PTFE=Polytetrafluoroethylene

World Headquarters

CAT PUMPS

1681 - 94th Lane N.E. Minneapolis, MN 55449-4324

Phone (763) 780-5440 — FAX (763) 780-2958

e-mail: techsupport@catpumps.com

www.catpumps.com

International Inquiries

FAX (763) 785-4329

e-mail: intlsales@catpumps.com



The Pumps with Nine Lives

CAT PUMPS (U.K.) LTD.

1 Fleet Business Park, Sandy Lane, Church Crookham

FLEET, Hampshire, GU52 8BF, England

Phone Fleet 44 1252-622031 — Fax 44 1252-626655

e-mail: sales@catpumps.co.uk

N.V. CAT PUMPS INTERNATIONAL S.A.

Heiveldkens 6A, B-2550 Kontich, Belgium

Phone 32-3-450.71.50 — Fax 32-3-450.71.51

e-mail: cpi@catpumps.be www.catpumps.be

CAT PUMPS DEUTSCHLAND GmbH

Buchwiese 2, D-65510 Idstein, Germany

Phone 49 6126-9303 0 — Fax 49 6126-9303 33

e-mail: catpumps@t-online.de www.catpumps.de