

Model 5CP3120G1 Shown

PUMP FEATURES

- Polished solid ceramic plungers last long and resist abrasion.
- Triplex plunger design providing low pulsation and quiet operation.
- Internally lubricated and cooled packings for extended life.

GEARBOX UNIT FEATURES

- No pulley selection or adjustment for quick, easy gas engine mounting.
- Totally sealed housing providing independent gearbox lubrication for maximum service life.
- Hardened steel helical design gears for smooth, quiet operation.

⚠ CAUTIONS AND WARNINGS

All High Pressure Systems require a primary pressure regulating device (i.e. regulator, unloader) and a secondary pressure relief device (i.e. pop-off valve, relief valve). Failure to install such relief devices could result in personal injury or damage to pump or property. CAT PUMPS does not assume any liability or responsibility for the operation of a customer's high pressure system.

Read all CAUTIONS and WARNINGS before commencing service or operation of any high pressure system. The CAUTIONS and WARNINGS are included in each service manual and with each Data sheet. CAUTIONS and WARNINGS can also be viewed online at www.catpumps.com/cautions-warnings or can be requested directly from CAT PUMPS.

WARRANTY

View the Limited Warranty on-line at www.catpumps.com/warranty.

Direct Drive CP Gearbox

Model 8076

Used on Models 5CP3120G1, 5CP5150G1

Model 8077

Used on Models 5CP3120G118, 5CP5150G118

Model 8081

Used on Model 7CP6110G1

SPECIFICATIONS

U.S. Measure

Metric Measure

8076 (1") or 8077 (1 1/8") Gearbox For 5CP3120

Flow	4.5 GPM	(17 L/M)
Pressure Range	100 to 3500 PSI	(7 to 245 BAR)
Maximum Pump RPM	1645 RPM	(1645 RPM)
Maximum Engine RPM	3353 RPM	(3353 RPM)
Horsepower-Electric	10.8 HP	(10.8 HP)
Bore	0.630"	(16 mm)
Stroke	0.709"	(18 mm)
Pump Crankcase Capacity	17 oz.	(0.57 L)
Weight	26.40 lbs.	(12.0 kg)
Dimensions w/Gearbox	10.50 x 11.00 x 6.42"	(267 x 279 x 163 mm)

8076 (1") or 8077 (1 1/8") Gearbox For 5CP5150

Flow	5.0 GPM	(19 L/M)
Pressure Range	100 to 3000 PSI	(7 to 210 BAR)
Maximum Pump RPM	1570 RPM	(1570 RPM)
Maximum Engine RPM	3200 RPM	(3200 RPM)
Horsepower-Electric	10.3 HP	(10.3 HP)
Bore	0.709"	(18 mm)
Stroke	0.650"	(16.5 mm)
Pump Crankcase Capacity	17 oz.	(0.57 L)
Weight	26.40 lbs.	(12.0 kg)
Dimensions w/Gearbox	10.50 x 11.00 x 6.42"	(267 x 279 x 163 mm)

8081 (1") Gearbox For 7CP6110

Flow	10.0 GPM	(38 L/M)
Pressure Range	100 to 2000 PSI	(7 to 140 BAR)
Maximum Pump RPM	1750 RPM	(1750 RPM)
Maximum Engine RPM	3400 RPM	(3400 RPM)
Horsepower-Electric	13.7 HP	(13.7 HP)
Bore	0.866"	(22 mm)
Stroke	1.024"	(26 mm)
Pump Crankcase Capacity	38 oz.	(1.15 L)
Weight	48 lbs.	(22 kg)
Dimensions w/Gearbox	13.47 x 11.78 x 6.42"	(342 x 299 x 163mm)

COMMON SPECIFICATIONS

Inlet Pressure Range	Flooded to 60 PSI	(Flooded to 4 BAR)
Maximum Liquid Temperature	160°F	(71°C)
Gear Ratio	2.0384 to 1	(2.0384 to 1)
Gearbox Capacity	10 oz.	(0.30 L)
Weight (8076, 8077)	6.38 lbs.	(2.9 kg)
Weight (8081)	8.03 lbs.	(3.6 kg)
Dimensions (8076, 8077)	8.19 x 4.53 x 6.42"	(208 x 115 x 163 mm)
Dimensions (8081)	8.19 x 5.18 x 6.42"	(208 x 132 x 163 mm)
Mounting Flange: SAE J609, Flange B, Extensions 4 (1"Ø) or 4a (1 1/8" Ø), Shaft Length = 3 1/4", Pilot Ø = 5 3/4", B.C. Ø = 6 1/2", Thread = 3/8"-16 UNC TAP		

"Customer confidence is our greatest asset"

EXPLODED VIEW

DIRECT DRIVE GEARBOX MODELS 8076, 8077, 8081

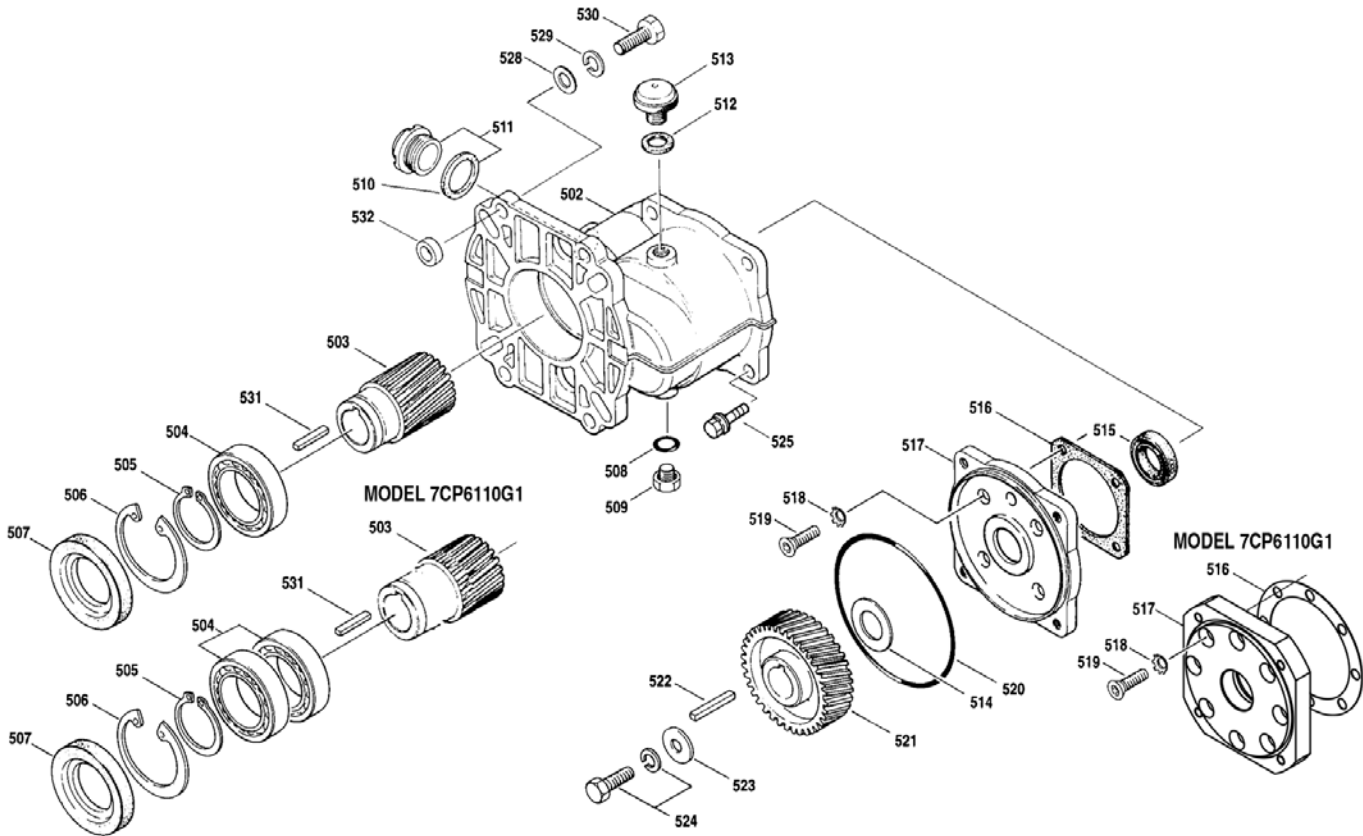

PARTS LIST

ITEM	P/N	MATL	DESCRIPTION	GEARBOX MODEL	QTY.	ITEM	P/N	MATL	DESCRIPTION	GEARBOX MODEL	QTY.
500	8076	AL	Gearbox, Helical (1" Shaft)	5CP3120G1, 5CP5150G1	1	516	46914	—	Gasket, Flange	8076, 8077	1
	8077	AL	Gearbox, Helical (1-1/8" Shaft)	5CP3120G118, 5CP5150G118	1		31383	NBR	Gasket, Flange	8081	1
	8081	AL	Gearbox, Helical (1" Shaft)	7CP6110G1	1	517	46913	AL	Flange, Bearing Cover	8076, 8077	1
502	44673	AL	Housing	All Models	1		76141	AL	Flange, Bearing Cover	8081	1
503	44675	STL	Gear, Pinion 1"	8076	1	518	126746	STCP R	Lockwasher, Conical (M8)	8076, 8077	4
	44690	STL	Gear, Pinion 1-1/8"	8077	1		992879	S	Lockwasher, Conical (M8)	8081	8
	45352	STL	Gear, Pinion 1"	8081	1	519	46124	STZP	Screw, FH (M8x16)	8076, 8077	4
504	56110	STL	Bearing, Ball	8076, 8077	1		992877	S	Screw, FH (M8x25)	8081	8
	56110	STL	Bearing, Ball	8081	2	520	14045	NBR	O-Ring, Flange	All Models	1
505	55459	STL	Ring, Retaining (External)	All Models	1	521	44711	STL	Gear, Helical	All Models	1
506	146423	STL	Ring, Retaining (Internal)	All Models	1	522	101814	STL	Key (M6 x 6 x 27)	All Models	1
507	44676	NBR	Seal, Oil, Pinion	All Models	1	523	126579	STZP R	Washer, Flat (M8)	All Models	1
508	23170	NBR	O-Ring, Drain Plug - 70D	All Models	1	524	92521	STZP	Screw, Retaining, HHC Sems(M8x20)	All Models	1
509	25625	STCP	Plug, Oil Drain (1/4"x19BSP)	All Models	1		126258	STCP R	Screw, Retaining, HHC Sems(M8x20)	All Models	1
510	44428	NBR	Gasket, Flat Flex, Oil Gauge - 80D	All Models	1	525	92530	STZP	Screw, HH Sems (M8x25)	All Models	4
511	92241	—	Gauge, Bubble Oil w/Gasket	All Models	1		126544	STCP R	Screw, HH Sems (M8x25)	All Models	4
512	103685	NBR	Gasket, Oil Cap	All Models	1	528	126574	STZP R	Washer, Flat (M10)	All Models	4
513	44374	—	Cap, Oil Filler	All Models	1	529	126231	STCP R	Lockwasher, (M10)	All Models	4
514	20129	STZP	Washer (M20)	8076, 8077	1	530	34100	STZP	Screw, HH (3/8-16 x 1-3/8")	All Models	4
	126577	STCP R	Washer (M20)	8076, 8077	1		126543	STCP R	Screw, HH (3/8-16 x 1-3/8")	All Models	4
	31414	STL	Spacer (M24)	8081	1	531	44455	STL	Key (1/4"x1/4"x2-5/32")	All Models	1
515	44679	NBR	Seal, Oil, Bearing Cover	8076, 8077	1	532	34042	AL	Spacer	All Models	4
	49190	NBR	Seal, Oil, Bearing Cover	8081	1						

R Components comply with RoHS Directive

MATERIAL CODES (Not Part of Part Number): AL=Aluminum NBR=Medium Nitrile (Buna-N) S=304SS STL=Steel STCP=Steel/Chrome Plated STZP=Steel/Zinc Plated

Before you begin servicing your pump, **Please carefully read OPERATOR'S MANUAL and separate SERVICE MANUAL** for special lubrication, disassembly and reassembly information.

SERVICING THE GEARBOX

DISASSEMBLY

1. **Completely drain lube** from gearbox housing.
2. Remove four (HHC) screws that fasten the gearbox to the engine and separate gearbox and pump from engine.
3. Remove four (HH) screws that fasten the gearbox to the bearing cover flange and separate gearbox housing from pump.
4. Place gearbox housing on work surface with **seal facing up**.
5. Remove pinion oil seal by inserting screwdriver between pinion gear and inner lid of seal and pry out. **Seal will be damaged and must be replaced.**
6. Remove large retaining ring in groove below the pinion oil seal using retaining ring pliers and set aside for re-use.
7. Remove the pinion gear and bearing. Turn gearbox housing over onto **engine mount flange surface**. Bearing is pressed into position so it is necessary to press pinion and bearing out from rear. Set gearbox housing aside.
8. Remove bearing from pinion gear. Using reverse pliers remove retaining ring from groove on pinion gear and press bearing from pinion. Set aside pinion, bearing and retaining ring.
9. Remove hex machined retaining screw, lockwasher and flat washer from center of helical drive gear on pump shaft.
10. Slip helical drive gear from crankshaft.
11. Remove key from keyway in pump crankshaft.

At this point the gearbox has been disassembled. Now begin examination of the gearbox parts for wear and reassembly.

While the gearbox is in this state of disassembly, it is advisable to examine your **pump** for any indication of wear.

If any of the following conditions are present, **removal of the bearing cover flange** is necessary. **Only trained technicians should service drive end.**

- Leakage between bearing cover flange and pump crankcase.
- Evidence of water in pump crankcase.
- Evidence of water in gearbox crankcase.

NOTE: If removal of bearing cover flange is necessary, completely drain oil from crankcase of pump.

REMOVING BEARING COVER FLANGE

1. Remove Flat head screws and lockwashers from bearing cover flange.
2. Tap flange with soft mallet to separate from pump crankcase.
3. Examine pump bearing and replace if worn.
4. Examine oil seal in bearing cover flange and replace if worn.
5. Examine gasket on **outside** of bearing cover flange and replace if cut or cracked.

6. Examine o-ring on **inside** outer groove of bearing cover flange and replace if cut or worn.

If further pump servicing is needed, refer to your pump service manual, and Tech Bulletin on "Servicing Crankcase Section".

REPLACING BEARING COVER FLANGE

1. Press new oil seal into bearing cover flange.
2. Line up holes and mount gasket on outside of bearing cover flange.
3. Line up inside mounting holes on bearing cover flange with holes on pump. **Exercise caution not to cut oil seal on keyway edge.**
4. Apply Loctite® 242® to the threaded area of screws before replacing and torque per chart.

REASSEMBLY

1. Slide Washer onto pump crankshaft.
2. Insert key into pump crankshaft keyway until flush with end of shaft.
3. Examine helical drive gear teeth for wear and replace if necessary. Line up keyway on gear with pump shaft keyway and key and slide gear onto shaft.
4. Install flat washer and retaining screw w/lockwasher onto shaft and torque per chart.
5. Examine gearbox oil gauge and oil drain plug for any evidence of leaking and replace o-ring and gasket if necessary.
6. Examine pinion bearing for wear and replace if necessary.
7. Examine pinion gear teeth for wear and replace if necessary.
8. Press bearing over pinion gear until seated on shoulder. On Model 7CP6110 with dual bearings, press first bearing on until seated, then second bearing until seated with first bearing.
9. Install retaining ring on pinion gear and **snap into groove**.
10. Insert pinion and helical gear assembly into gearbox housing and press into position until seated on shoulder. **Groove for large retaining ring must be visible.**
11. Insert large retaining ring into pinion bearing housing and snap into groove.
12. Lubricate I.D. and O.D. of new pinion oil seal. Place oil seal at mouth of pinion bearing housing with **garter spring facing down**. Carefully press seal into position until seated on retaining ring. **Keep seal square in position to avoid inner lip hanging up on pinion gear edge.**
13. Rotate pinion gear with keyway up. Mount assembled gearbox housing with helical drive gear onto pump shaft.
NOTE: Carefully match pinion gear teeth and line up mounting holes. **Place engine and helical mounting flange in forward position.**
14. Install screws to fasten gearbox to bearing cover flange and torque per chart.

MOUNTING PUMP WITH GEARBOX ONTO ENGINE

1. Rotate crankshaft of engine until keyway is at top.
2. Insert key into keyway and generously apply Loctite 76764 antiseize lubricant to engine shaft.
3. Line up keyway of pinion gear and engine shaft and carefully slip gearbox onto engine shaft until flush with engine face. Install four hex machined screws and torque per chart.

NOTE: Due to varying engine shaft lengths it may be necessary to install a small **spacer** on each of the four (4) hex machined screws between gear box flange and engine face.

4. **Before starting operation**, fill gearbox housing to oil gauge dot with Cat Pumps gear lube PN 6110 or a 80-90 weight **gear lube**. Fill crankcase of pump to oil gauge dot with Cat Pumps special premium grade hydraulic oil PN 6107.

FIELD CONVERSION FOR STANDARD PUMP

To convert from a standard pump to a gearbox pump, remove the existing bearing cover, o-ring and four combination head screws. Replace with new gearbox bearing cover flange, flange gasket, lockwashers and screws.

The bearing for pump Model 7CP6110 is a tapered roller with an outer race. Remove the standard bearing cover from the pump. Remove outer race from bearing cover by gently pounding on work surface to unseat. Then use a bearing puller tool to pull race from bearing cover. Press outer race into gearbox bearing cover over flange. Be certain race is completely seated in flange before mounting onto pump.

TORQUE CHART

Description	Thread	Tool	Torque
Gearbox Housing to Bearing Cover Flange	M8	13 mm	70 in. lbs. (7.8 Nm)
Bearing Cover Flange to Pump (M8)	M8	5 mm	125 in. lbs. (14.1 Nm)
Drive Gear Retaining Screw	M8	13 mm	110 in. lbs. (12.3 Nm)
Engine Mounting Screw	3/8-16	9/16"	110 in. lbs. (12.3 Nm)

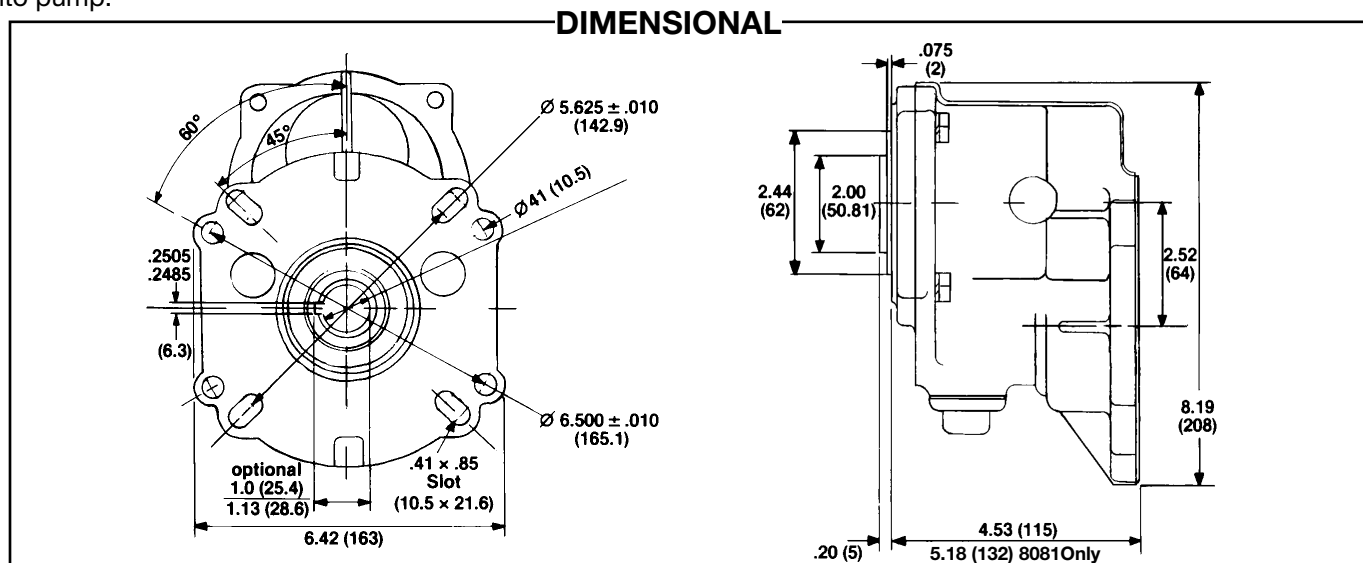

World Headquarters

Cat Pumps

1681 - 94th Lane N.E. Minneapolis, MN 55449-4324

Phone (763) 780-5440 — FAX (763) 780-2958

e-mail: techsupport@catpumps.com

www.catpumps.com

International Inquiries

FAX (763) 785-4329

e-mail: intlsales@catpumps.com



The Pumps with Nine Lives

Cat Pumps (U.K.) LTD.

1 Fleet Business Park, Sandy Lane, Church Crookham

FLEET, Hampshire, GU52 8BF, England

Phone Fleet 44 1252-622031 — Fax 44 1252-626655

e-mail: sales@catpumps.co.uk www.catpumps.co.uk

N.V. Cat Pumps INTERNATIONAL S.A.

Heiveldekens 6A, B-2550 Kontich, Belgium

Phone 32-3-450.71.50 — Fax 32-3-450.71.51

e-mail: cpi@catpumps.be www.catpumps.be

Cat Pumps DEUTSCHLAND GmbH

Buchwiese 2, D-65510 Idstein, Germany

Phone 49 6126-9303 0 — Fax 49 6126-9303 33

e-mail: catpumps@t-online.de www.catpumps.de