

Model Shown (76334)

Crankcase Oil Indicator and Drain Kits

Models

Oil Level Indicator 76144

Oil Level Indicator w/drain Kit 76334

**Drain Kits 34314, 34334
990394**

FEATURES

- Easily monitor crankcase oil level at-a-glance and avoid unplanned shutdowns, improving profitability.
- Improve pump maintenance management processes.
- Conveniently monitor oil when existing bubble gauge is obscured (Model 76144).
- Easily drain crankcase oil for scheduled maintenance (Model 76334).
- Indicator shield can rotate 360° for optimum viewing.

SPECIFICATIONS

VENTED STYLE

Maximum working temperature 250 °F (121°C)

Weight (76144)..... 4 oz(0.11 kg)

Weight (76334) 1.16 lbs(0.53 kg)

Weight (34314)..... 1.19 lbs(0.54 kg)

Weight (34334) 14.5 oz(0.41 kg)

Weight (990394)..... 1.08 lbs(0.49 kg)

Dimensions for model 76144 assembly:

Indicator only – 11 /16" hex flats x 6.0" (17.5 x 152.4 mm).

2.50" (63.5 mm) extension from rear cover to end of assembly

⚠ CAUTIONS AND WARNINGS

All High Pressure Systems require a primary pressure regulating device (i.e. regulator, unloader) and a secondary pressure relief device (i.e. pop-off valve, relief valve). Failure to install such relief devices could result in personal injury or damage to pump or property. CAT PUMPS does not assume any liability or responsibility for the operation of a customer's high pressure system.

Read all CAUTIONS and WARNINGS before commencing service or operation of any high pressure system. The CAUTIONS and WARNINGS are included in each service manual and with each Accessory Data sheet. CAUTIONS and WARNINGS can also be viewed online at www.catpumps.com/cautions-warnings or can be requested directly from CAT PUMPS.

WARRANTY

View the Limited Warranty on-line at www.catpumps.com/warranty.

Selection Chart

Crankcase Oil Level Indicator and Drain Kit

MODEL	DESCRIPTION	PUMP MODELS
76144	Crankcase oil level indicator with adapter and plug	Piston pumps: 1520 thru 6041 Plunger pumps: 2510 thru 6861K except 35 and 38 frame series
76334	Crankcase oil level indicator with oil drain kit 34334	All piston and plunger pumps and 66DX, except plunger pumps 1DX, 2DX, 2SF, 2SFX, 3DX, 3DNX, 3SP, 3SPX and 4SF series

Oil Drain Kits (without crankcase oil level indicator)

MODEL	DESCRIPTION	PUMP MODELS
34334	Oil drain kit with 3/8" x 24" drain hose, bracket, 1/4" NPTM square end oil drain plug and other fittings	All piston and plunger pumps and 66DX, except plunger pumps 1DX, 2DX, 2SF, 2SFX, 3DX, 3DNX, 3SP, 3SPX and 4SF series
34314	Oil drain kit with 3/8" x 48" drain hose, bracket, 1/4" NPTM square end oil drain plug and other fittings	Piston pumps: 6020 thru 6041 Plunger pumps: 3501 thru 3560, 3801 thru 3841K, 6747 thru 6777, and 6801 thru 6861K
990394	Oil drain kit with 3/8" x 24" drain hose, bracket, 1/4" NPTM square end oil drain plug and other fittings	Plunger pumps: 1DX, 2DX, 2SF, 2SFX, 3DX, 3DNX, 3SP, 3SPX and 4SF series

Assembly Instructions Crankcase Oil Level Indicator (76144)

1. If retrofitting an existing pump – Drain oil from pump.
2. Remove chrome-plated drain plug and o-ring from rear cover of pump.
3. Install 1/4" BSP fitting (Figure 1, item 4) with o-ring (5) into rear cover of pump.
4. Thread in tee (2) to fitting (4).
5. Thread in square end plug (3) into tee (2).
6. Thread in crankcase oil level indicator (1) into open port of vertical leg of tee (2).
7. Rotate shield for optimum viewing.

Filling Instructions

1. Ensure square end plug (3) is installed at end of tee (2).
2. Remove red oil cap from top of pump.
3. Fill pump to capacity as stated in pump data sheet. Add an additional .25 oz of oil to fill crankcase oil level indicator (1) to center of indicator.
4. Reinstall red oil cap.
5. Position silver label on crankcase oil level indicator (1) so that the "FULL" line is level with the oil when pump is not running (Figure 1).

NOTE: Wipe indicator (1) with mild solvent to remove oil residue before applying label.

Parts List

ITEM	PN	MTL	DESCRIPTION	QTY
1	—	BB	Indicator, Level, Oil	1
2	—	BB	Tee, Straight, 1/4" NPT	1
3	—	BB	Plug, Square End, 1/4" NPTM	1
4	—	BB	Fitting, 1/4" -19 BSP	1
5	—	NBR	O-Ring, Fitting, 70 D	1
6	31536	—	Kit, Repair (Incls glass, gaskets)	1

MATERIAL CODES (Not part of part number)
BB = Brass, NBR = Medium Nitrile (Buna-N)

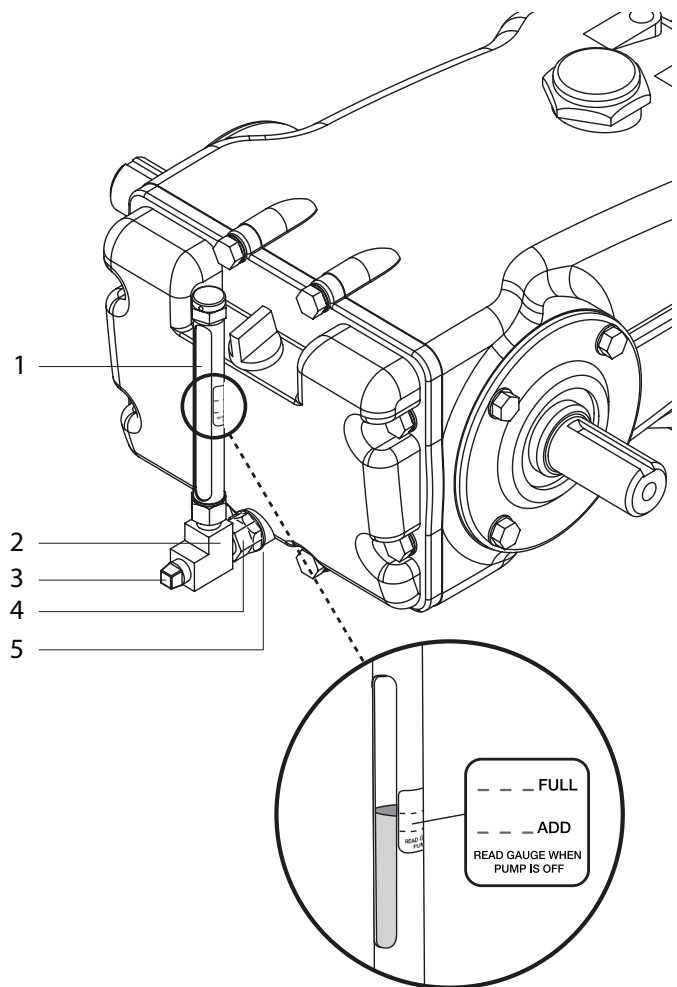

Figure 1

Assembly Instructions Crankcase oil level indicator with drain kit (76334)

1. If retrofitting an existing pump – Drain oil from pump.
2. Remove chrome-plated drain plug and o-ring from rear cover of pump.
3. Install 1/4" BSP fitting (Figure 2, item 2) with o-ring (3) into rear cover of pump.
4. Attach hose barbs (7) to each end of 3/8" hose (8).
5. Thread one end of hose (8) into fitting (2) of rear cover.
6. On opposite end of hose (8), thread in tee (4). Position tee (4) with female threads up.
7. Remove nut from 1/4" union fitting (6).
8. Thread in hose (8) with tee (4) to large end of union fitting (6).
9. Mount bracket (9) with screws (10) into desired position such that the centerline of the sight area of the crankcase oil indicator (1) is at the same center line of the pump (See Figure 3)
10. Install hose assembly through mounting bracket (9)
11. Reinstall nut onto threads of union fitting (6) and tighten.
12. Thread in square end plug (5) into open end of union fitting (6).
13. Thread in crankcase oil level indicator (1) into open port of vertical leg of tee (4).
14. Rotate shield for optimum viewing.

Filling Instructions

1. Ensure square end plug (5) is installed in union fitting (6)
2. Remove red oil cap from top of pump.
3. Fill pump to capacity as stated in pump data sheet. Add an additional 2 oz. of oil to fill crankcase oil level indicator (1) and drain hose (8) to center of indicator.
4. Reinstall red oil cap.
5. Position silver label on crankcase oil level indicator (1) so that the "FULL" line is level with the oil when pump is not running (See View A)

NOTE:

Wipe indicator (1) with mild solvent to remove oil residue before applying label (See view A).

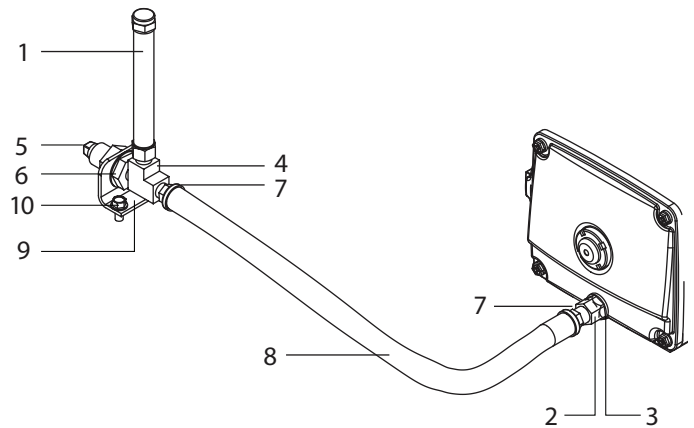

Figure 2

Parts List

ITEM	PN	MTL	DESCRIPTION	QTY
1	—	BB	Indicator, Level, Oil	1
2	—	BB	Fitting, 1/4" -19 BSP	1
3	—	NBR	O-Ring, Fitting, 70 D	1
4	—	BB	Tee, 1/4" NPT straight	1
5	—	BB	Plug, Square End, 1/4" NPTM	1
6	—	BB	Union, 1/4" NPT	1
7	—	BB	Barb, Hose, 1/4" NPTM x 3/8" Hose	2
8	—	—	Hose, 3/8" x 24", 300psi	1
9	—	STZP	Bracket, Oil Drain	1
10	—	STZP R	Screw, 1/4" - 20 x 1/2"	2
11	31536	—	Kit, Repair (Incls glass, gaskets)	1

MATERIAL CODES (Not part of part number)

BB = Brass, NBR = Medium Nitrile (Buna-N), STZP = Steel/Zinc Plated
R Components comply with RoHS Directive.

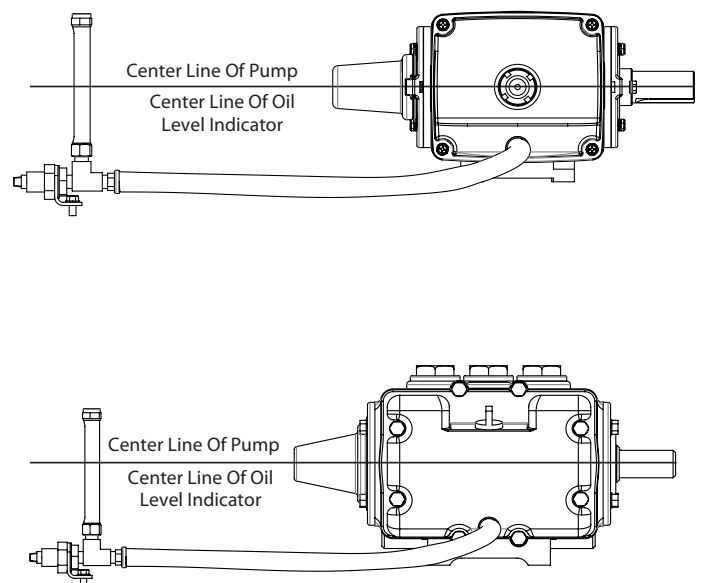

Figure 3

Assembly Instructions Oil Drain Kits (34314 and 34334)

1. If retrofitting an existing pump – Drain oil from pump.
2. Remove chrome-plated drain plug and o-ring from rear cover of pump.
3. Install 1/4" BSP fitting (Figure 4, item 1) with o-ring (2) into rear cover of pump.
4. Attach hose barbs (5) to each end of 3/8" hose (6).
5. Thread one end of hose (6) into fitting (1) of rear cover.
6. Remove nut from 1/4" union fitting (4).
7. Thread in hose (6) with barb end into large end of union fitting (4).
8. Mount bracket (7) with screws (8) into desired position to maximize drainage.
9. Install hose assembly with union fitting end through mounting bracket (7) or panel (Bulkhead hole is .78" diameter).
10. Reinstall nut onto threads of union fitting (4) and tighten.
NOTE: Centerline to centerline dimension for bracket (7) hole is 1.50", drill two - .209 diameter holes.
11. Thread in square end plug (3) into threaded end of union fitting (4).

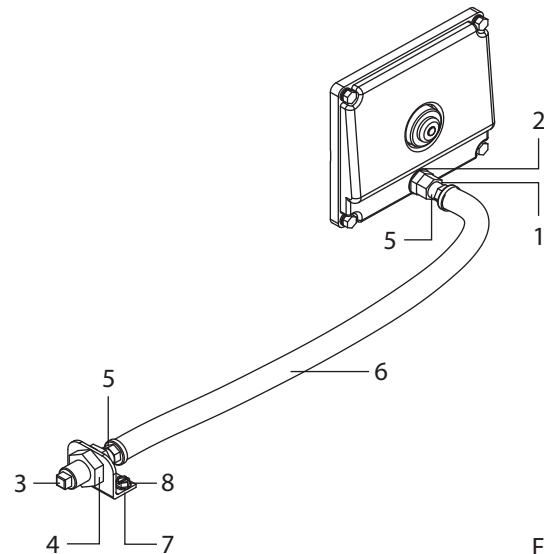

Figure 4

Assembly Instructions Oil Drain Kit (990394)

1. If retrofitting an existing pump – Drain oil from pump.
2. Remove black drain cap and o-ring from crankcase body.
3. Using same o-ring, position o-ring onto adapter (item 9).
4. Install adapter (9) with o-ring into crankcase body drain hole.
5. Thread in elbow (10) into adapter (9).
6. Attach hose barbs (5) to each end of 3/8" hose (6).
7. Thread one end of hose (6) into elbow (10).
8. Remove nut from 1/4" union fitting (4).
9. Thread in hose (6) with barb end into large end of union fitting (4).
10. Mount bracket (7) with screws (8) into desired position to maximize drainage.
NOTE: Centerline to centerline dimension for bracket (7) hole is 1.50", drill two - .209 diameter holes.
11. Install hose assembly with union fitting end through mounting bracket (7) or panel (Bulkhead hole is .78" diameter).
12. Reinstall nut onto threads of union fitting (4) and tighten.
13. Thread in square end plug (3) into threaded end of union fitting (4).

Filling Instructions

1. Ensure square end plug (3) is installed in union fitting (4).
2. Remove red oil cap from top of pump.
3. Fill pump to capacity as stated in pump data sheet. Add more oil as required to fill drain hose (6).
4. Loosen square end plug (3) to release potential air in hose (6).
5. Tighten square end plug (3).
6. Add more oil as necessary, reinstall red oil cap.

Parts List

ITEM	DRAIN KIT	MTL	DESCRIPTION	QTY
1	34334, 34314	BB	Fitting, 1/4"-19 BSP	1
2	34334, 34314	NBR	O-Ring, Fitting,70D	1
3	34334, 34314 990394	BB	Plug, Square End, 1/4" NPTM	1
4	34334, 34314 990394	BB	Union, 1/4" NPT	1
5	34334, 34314 990394	BB	Barb, Hose, 1/4" NPTM x 3/8" Hose	2
6	34334, 34314 990394	—	Hose, 3/8" x 24", 300psi	1
7	34334, 34314 990394	STZP	Bracket, Oil Drain	1
8	34334, 34314 990394	STZP R	Screw, 1/4" - 20 x 1/2"	2
9	990394	BB	Adapter (Not Shown)	1
10	990394	BB	Elbow, 1/4"NPTM x 1/4" NPTF (Not Shown)	1

MATERIAL CODES (Not part of part number)

BB = Brass, NBR = Medium Nitrile (Buna-N), STZP = Steel/Zinc Plated
R Components comply with RoHS Directive.

TROUBLESHOOTING (Problem: Leaking Oil)

PROBABLE CAUSE	SOLUTION
Loose Connection	Tighten or use PTFE thread tape
Worn Seals	Install Repair Kit
Cracked Glass	Install Repair Kit
Too Much Oil	Drain Oil
Damaged Hose	Replace Hose
Position of Mounting Bracket is incorrect	Reposition Bracket



CAT PUMPS

1681 - 94TH LANE N.E. MINNEAPOLIS, MN 55449-4324
PHONE (763) 780-5440 — FAX (763) 780-2958
e-mail: techsupport@catpumps.com
www.catpumps.com