



Stainless Steel Pressure Regulator

Model **7370**

FEATURES

- Maintains full pressure while running in idle for quick return to system pressure.
- Conical piston and seat provide a consistently smooth flow that reduces wear and compensates for pressure spikes for extended valve life.
- Minimum pressure fluctuations with the alternating use of multiple guns and nozzles.
- Top adjusting handle and locking nut to secure calibrated pressure setting.
- No external moving parts. Stainless Steel and FPM internal parts for temperature and liquid compatibility.

SPECIFICATIONS

	U.S. Measure	Metric Measure
Flow Range.....	1-12 GPM	(3.8-45 L/M)
Pressure Range	400-1500 PSI	(28-105 BAR)
Maximum Temperature.....	180°F	(82°C)
Inlet Port	1/4" NPTF	(1/4" NPTF)
By-Pass Port.....	3/8" NPTF	(3/8" NPTF)
Weight.....	1.42 lbs.	(0.64 kg)
Dimensions	2.26x6"	(56x152 mm)

⚠ WARNING

All systems require both a primary pressure regulating device (i.e., regulator, unloader) and a secondary pressure safety relief device (i.e., pop-off valve, safety valve). Failure to install such relief devices could result in personal injury or damage to the pump or to system components. CAT PUMPS does not assume any liability or responsibility for the operation of a customer's high pressure system.

90 DAY WARRANTY

Refer to complete CAT PUMPS Warranty for further information.

“Customer confidence is our greatest asset”

SELECTION

This pressure regulator is designed for systems with single or multiple pumps, solenoid (gate) valves, nozzles, standard or “weep” guns.

Note: For multiple pump systems, it is best to use a pressure regulator not a pressure sensitive regulating unloader.

This regulator should meet both the desired system flow (combined nozzle flow rate requirement) and the desired system pressure.

NOTICE: Operation below the minimum flow of the regulator causes the regulator to cycle or chatter. Operation above the maximum flows of the regulator causes premature regulator wear, regulator cycling and prevents attaining desired system pressure.

INSTALLATION

This regulator operates properly when mounted in any direction; however, it is preferred to keep the plumbing to a minimum and the adjusting cap easily accessible. The best mounting location is directly on the pump discharge manifold head or in discharge line using a “T” fitting. Flexible, high pressure hose (minimum single wire braid) should be at least the size of the regulator ports when plumbing to and from the regulator.

The inlet connection is located on the side and is a 1/4" NPTF sized port. Plumb into this port for discharge flow from the pump.

The by-pass connection is located on the bottom and is a 3/8" NPTF sized port. By-pass fluid is directed out of this port and can be routed to a reservoir or to a drain.

OPERATION

This pressure regulator maintains established system pressure in the discharge line and at the pump head when the trigger gun is closed, solenoid (gate) valve is closed or the nozzles are clogged, thus by-passing all unrequired flow. Squeezing the trigger gun or opening the solenoid (gate) valve allows for a quick return to established system pressure.

PRESSURE ADJUSTMENT

1. Setting and adjusting the regulator pressure must be done with the system “on”.
2. Start the system with regulator backed off to the lowest pressure setting (counterclockwise direction).
3. Squeeze the trigger and read the pressure on the gauge at the pump.

Note: Do not read the pressure at the gun or nozzle.

4. If more pressure is desired, release the trigger, turn adjusting cap one quarter turn in clockwise direction.
5. Squeeze the trigger and read the pressure.
6. Repeat this process until desired system pressure is attained.
7. Once the desired system pressure is reached, stop turning the adjusting cap and thread jam nut down towards upper body of regulator to lock in place.

NOTICE: A minimum by-pass flow of 5% of the regulator rated flow is required for proper regulator performance. If the entire output is directed through the nozzles (zero by-pass) the “cushioning” feature of the by-pass liquid is eliminated and the regulator can malfunction or wear prematurely.

8. If desired system pressure cannot be reached, review TROUBLESHOOTING chart.
9. When servicing existing systems, back off jam nut.
10. Follow adjustment procedures as stated above for new regulators.

Note: Do not adjust regulators pressure setting to compensate for a worn nozzle. Check the nozzle as part of the regular maintenance and replace if worn.

Note: A secondary pressure safety relief device (i.e., pop-off valve, safety valve) should be used along with this pressure regulator. Final adjustment for the relief valve should relieve at 200 psi above the system operating pressure.

TYPICAL REGULATOR INSTALLATION

- 1 Pressure Gauge
- 2 Relief Valve
Shown as a secondary safety relief valve
- 3 Pulsation Dampener
- 4 Pressure Regulator
- 5 Triplex Plunger Pump

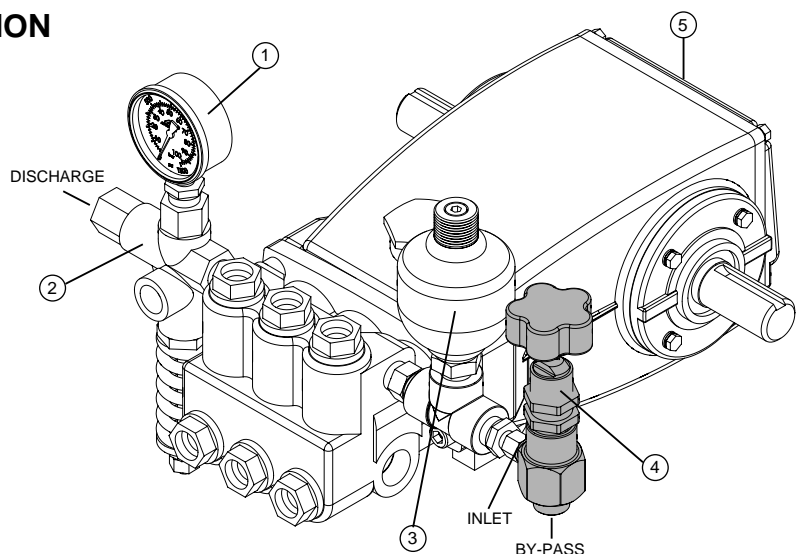

⚠ WARNING:

Electrical shock, high voltages can cause personal injury, death or property damage. Moving, rotating or reciprocating parts can crush and cut, causing personal injury, death, or property damage.

Therefore, before commencing with service work, shut down or disengage the pump and all accessory equipment before attempting any type of service. Adhere to "Lock Out" and "Tag Out" procedures for electrical equipment. For mobile equipment, be sure engines and hydraulics cannot be accidentally started. Relieve all discharge line pressure by triggering gun or opening valve in discharge line.

SERVICING

Disassembly:

1. Disconnect by-pass and inlet plumbing from regulator.
2. Remove regulator from pump.
3. Secure lower body of regulator in a vise with adjusting cap facing upwards.
4. Remove adjusting cap by unthreading from upper body in a counterclockwise direction.
5. Remove upper body by unthreading from lower body.
6. Remove spring retainer, spring and conical piston.

NOTICE: Exercise extreme caution to avoid contact and damage to outside diameter and sharp tip of conical piston.

7. Remove lower body from vise and place on flat surface with by-pass port facing upwards.
8. Using a tool with the same diameter as that of the conical seat drive out the conical seat and piston retainer.

NOTICE: Exercise extreme caution to avoid contact and damage to the inside diameter of the piston retainer as well as the outside diameter and tapered surfaces of the conical seat.

Note: With the regulator completely disassembled, inspect sealing area where the conical seat and piston retainer makes contact within the lower body of the regulator for grooves, pitting and wear. If damage is found, stop the repair and replace with new lower body or complete new regulator. If not, proceed with reassembly.

Reassembly:

1. Place lower regulator body with by-pass port facing downwards in a vise.
2. Lubricate and install o-ring onto outside diameter of conical seat. Press conical seat down into lower regulator body with tapered surface facing upwards.
3. Lubricate and install o-ring onto piston retainer. Press piston retainer with larger diameter facing downwards.
4. Place conical piston on a flat surface with sharp point facing upwards. Lubricate and install backup-ring, then o-ring onto outside diameter of conical piston. Lubricate outside diameter of conical piston.
5. Press conical piston with sharp point down into piston retainer.
6. Place spring and then spring retainer onto conical piston.
7. Thread upper body into lower body.
8. Thread adjusting cap into upper body.
9. Re-install regulator onto pump.
10. Reconnect by-pass and inlet plumbing to regulator.
11. Proceed to PRESSURE ADJUSTMENT.

TROUBLESHOOTING

Cycling/Chattering

- Too little flow for valve specifications.
- Air in system, poor connections.
- Inlet seals in pump worn.
- O-ring in gun worn.

System will not build up to pressure

- Nozzle worn.
- Improper nozzle size for system specs.
- Foreign material trapped in seat.

Pressure drop

- Nozzles worn.
- Piston and seat in regulator worn.
- Air in system, poor connections.
- Insufficient flow to pump.
- Filter clogged. Check and clean regularly.

Pressure spikes while in by-pass

- Minimum by-pass of 5% not present.
- Excessive pressure adjustment made for worn nozzle. REPLACE NOZZLE. Reset system pressure.

Leakage from regulator vent hole

- O-ring around piston worn or piston retainer scored. Service with o-ring kit.

Approximate Pressure Reading at Gauge	Gauge Between Pump/Unloader	Gauge Between Unloader/Gun-Nozzle-Valve
System in operation (gun open)	system pressure	system pressure
System in by-pass (all guns, valves closed)	200-300 PSI above system pressure	200-300 PSI above system pressure

EXPLODED VIEW

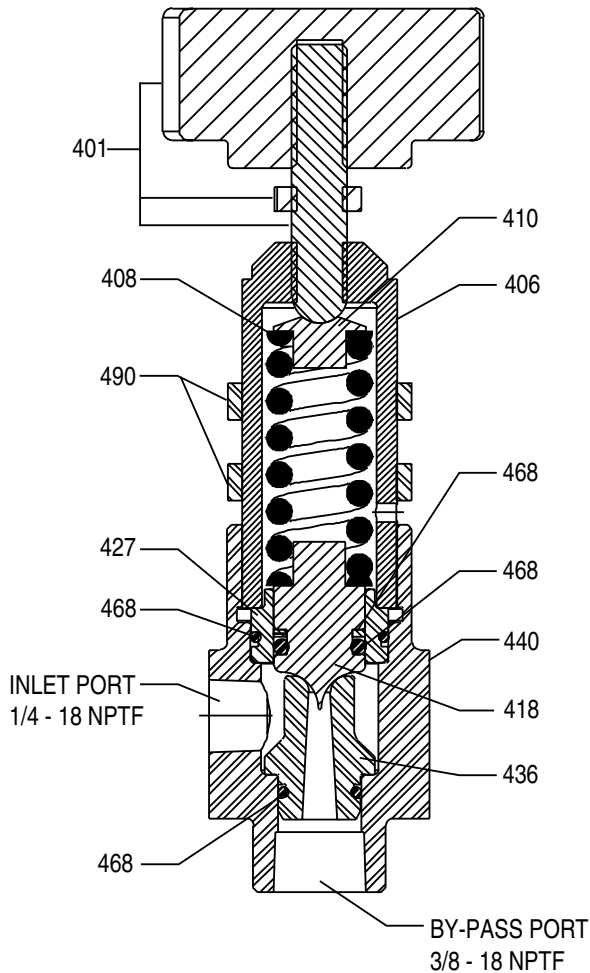

PARTS LIST

ITEM	P/N	MATL	DESCRIPTION	QTY
401	30580	—	Handle, Adjusting, Assembly (Incls: Handle, Stud, Locknut)	1
406	30541	STNP	Body, Upper	1
408	—	ZP	Spring, Pressure	1
410	30726	BB	Retainer, Spring	1
418	30566	SSB	Piston, Conical	1
427	31488	SS	Retainer, Piston	1
436	30724	SSB	Seat, Conical	1
440	30538	SS	Body, Lower	1
468	30749	FPM	Kit, O-Ring	1
490	34090	S	Panel Mount Assy	2

Italics are optional items.

MATERIAL CODES (Not Part of Part Number):

BB=Brass FPM=Fluorocarbon S=304SS SS=316SS

SSB=316SS Condition B STNP=Steel Nickel Plated Z=Zinc Plated

World Headquarters

CAT PUMPS

1681 - 94th Lane N.E. Minneapolis, MN 55449-4324

Phone (763) 780-5440 — FAX (763) 780-2958

e-mail: techsupport@catpumps.com

www.catpumps.com

International Inquiries

FAX (763) 785-4329

e-mail: intlsales@catpumps.com



The Pumps with Nine Lives

CAT PUMPS (U.K.) LTD.

1 Fleet Business Park, Sandy Lane, Church Crookham

FLEET, Hampshire, GU52 8BF, England

Phone Fleet 44 1252-622031 — Fax 44 1252-626655

e-mail: sales@catpumps.co.uk www.catpumps.co.uk

N.V. CAT PUMPS INTERNATIONAL S.A.

Heiveldkens 6A, B-2550 Kontich, Belgium

Phone 32-3-450.71.50 — Fax 32-3-450.71.51

e-mail: cpi@catpumps.be www.catpumps.be

CAT PUMPS DEUTSCHLAND GmbH

Buchwiese 2, D-65510 Idstein, Germany

Phone 49 6126-9303 0 — Fax 49 6126-9303 33

e-mail: catpumps@t-online.de www.catpumps.de