



## Adjustable Chemical Injector

**Brass Models** 7182, 7183, 7184

**SS Models** 7722, 7723, 7724

Standard Discharge Line

**Brass Models** 7192, 7193, 7194

For Unloaders 7500S, 7500XS, 7580, 7581, 7600S

**Brass Models** 7222, 7223, 7224

For Unloaders 7620, 7627, 7670, 7672, 7690

### FEATURES

- Durable stainless steel orifice for chemical compatibility.
- Convenient top handle for adjusting chemical draw.
- Lightweight, compact unit.
- Optional pump discharge line installation or mount directly to the unloader discharge port.

**SELECTION:** Select the chemical injector that mounts most conveniently to your system and meets the flow requirements of the system. For discharge line installation select the brass injector models 7182, 7183 or 7184 or stainless steel models 7722, 7723 or 7724. For mounting directly to the 7500S, 7500XS, 7600S, 7580 and 7581 unloaders, select injector models 7192, 7193 or 7194 and for mounting directly to the 7670, 7672 and 7690 unloaders, select the injector models 7222, 7223 or 7224.

### SPECIFICATIONS

	U.S. Measure	Metric Measure
<b>MODELS 7182, 7192, 7222, 7722</b>		
Flow.....	3-4 GPM	(11.4-15 L/M)
Nozzle Orifice .....	1.8 mm	(1.8 mm)
<b>MODELS 7183, 7193, 7223, 7723</b>		
Flow.....	4-5 GPM	(15-19 L/M)
Nozzle Orifice .....	2.1 mm	(2.1 mm)
<b>MODELS 7184, 7194, 7224, 7724</b>		
Flow.....	5-6 GPM	(19-23 L/M)
Nozzle Orifice .....	2.3 mm	(2.3 mm)
<b>COMMON SPECIFICATIONS</b>		
Max. Pressure.....	3500 PSI	(245 BAR)
Max. Temperature.....	195°F	(90°C)
Barb Hose .....	1/4"	(1/4")
Inlet Port (7182, 7183, 7184) .....	3/8" NPTM	(3/8" NPTM)
(7722, 7723, 7724) .....	3/8" NPTM	(3/8" NPTM)
(7192, 7193, 7194) .....	M18 x 1.0	(M18 x 1.0)
(7222, 7223, 7224) .....	M22 x 1.5	(M22 x 1.5)
Discharge Port .....	3/8" NPTM	(3/8" NPTM)
Weight.....	6.3 oz.	(.18 kg)
Dimensions.....	2 x 1 x 3"	(51 x 25 x 76 mm)

**INSTALLATION:** The adjustable chemical injector should be mounted downstream from the system regulating device or directly onto the discharge port of one of the various unloaders.

To install either of the **unloader mount injectors**, remove the male discharge fitting with check valve and spring from the unloader. **Reinstall the spring, then the check valve into the injector** and thread onto unloader. NOTE: **Discard both o-ring and unloader discharge fitting.**  
(continued on back)

*“Customer confidence is our greatest asset”*

## EXPLODED VIEW

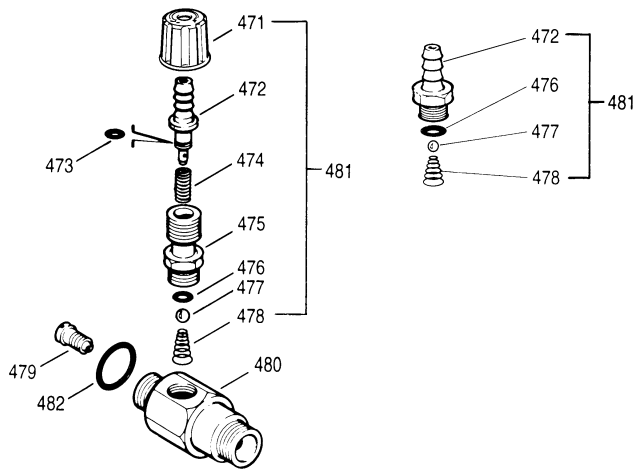

## CUTAWAY

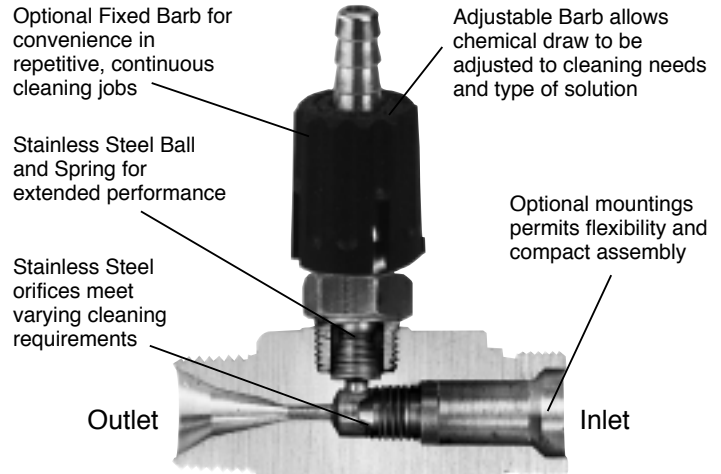

## PARTS LIST

ITEM	P/N	MATL	DESCRIPTION	MODEL USED	QTY
471	33949	NY	Handle, Adjustment	All	1
472	32941	BB	Barb, Adjustable	All	1
	—	S	Barb, Adjustable	7722, 7723, 7724	1
	33505	BB	Barb, Fixed	All	1
473	—	NBR	O-Ring, Hose Barb	All	1
	33955	FPM	O-Ring, Hose Barb	7722, 7723, 7724	1
474	33500	S	Spring, Retainer	All	1
475	33946	BB	Retainer, Ball/Seat	All	1
	39906	S	Retainer, Ball/Seat	7722, 7723, 7724	1
476	33504	FPM	O-Ring, Retainer	All	1
	33956	PTFE	O-Ring, Retainer	7722, 7723, 7724	1
477	34620	SS	Ball, Seat 1/4"	All	1
	33502	SS	Ball, Seat 7/32"	7722, 7723, 7724	1
478	33501	SS	Spring, Ball	All	1
479	32072	SSS	Injector Orifice (1.8 mm)	7182	1
	32073	SSS	Injector Orifice (2.1 mm)	7183	1
	32074	SSS	Injector Orifice (2.3 mm)	7184	1
<b>Injector for Unloaders 7500S, 7500XS, 7600S, 7580, 7581</b>					
479	32372	S	Injector Orifice (1.8 mm)	7192	1
	32373	S	Injector Orifice (2.1 mm)	7193	1
	32374	S	Injector Orifice (2.3 mm)	7194	1
<b>Injector for Unloaders 7670, 7672</b>					
479	32072	SSS	Injector Orifice (1.8 mm)	7222	1
	32073	SSS	Injector Orifice (2.1 mm)	7223	1
	32074	SSS	Injector Orifice (2.3 mm)	7224	1
480	—	BB	Body	All	1
481	33481	BBNY	Barb Assy, Adjustable	All	1
			(Incls: 471,472,473,474,475,476,477,478)		
	33480	BB	Barb Assy, Fixed	All	1
			(Incls: 472,476,477,478)		
482	13969	NBR	O-Ring, Body - 70D	All	1

*Italics are optional items.*

Material Codes (Not Part of Part No.): BB=Brass FPM=Fluorocarbon  
NBR=Medium Nitrile (Buna-N) NY=Nylon S=304SS SS=316SS SSS=416SS

**OPERATION:** The Chemical Injector is designed to **draw chemical only under low pressure**. It should be used with a double lance fitted with a low and high pressure nozzle, dual nozzle, adjustable nozzle or vari-nozzle. **When chemical is desired, the system must be switched over to the low pressure nozzle to draw chemical.** The amount of chemical draw may be varied by turning the adjustment collar completely into the body to stop draw and approximately 1-1/2 turns counterclockwise for maximum chemical draw. During normal high pressure operation there will be a pressure drop across the injector. See performance chart.

### CAUTION:

Deduct the pressure drop shown in the performance chart from your desired system pressure to arrive at the maximum high pressure nozzle rating. This is essential to avoid over-pressurizing the pump.

Example:

$$\left[ \begin{array}{l} \text{System - 4 GPM, 2000 PSI} \\ \text{Injector - 7183} \\ \text{Pressure Drop - 250 PSI} \end{array} \right] = \left[ \begin{array}{l} \text{Low Pressure Nozzle - 375 PSI} \\ \text{Max. High Pressure Nozzle - 1750 PSI} \end{array} \right]$$

Flush system after chemical application to prevent clogging and to prolong life.

## PERFORMANCE CHART

Model	Desired Flow	Orifice Size (mm)	Low PSI Nozzle (max. injecting pressure less hose friction loss)	Max. Chemical Draw (oz/min)	Pressure Drop across orifice (deduct from Hi-Pressure)
7182, 7192, 7222, 7722	2 GPM	1.8	225 psi	60	150
7182, 7192, 7222, 7722	3 GPM	1.8	275 psi	60	300
7182, 7192, 7222, 7722	4 GPM	1.8	450 psi	60	500
7183, 7193, 7223, 7723	3 GPM	2.1	225 psi	54	150
7183, 7193, 7223, 7723	4 GPM	2.1	375 psi	54	250
7183, 7193, 7223, 7723	5 GPM	2.1	600 psi	54	400
7184, 7194, 7224, 7724	3 GPM	2.3	150 psi	50	125
7184, 7194, 7224, 7724	4 GPM	2.3	225 psi	50	220
7184, 7194, 7224, 7724	5 GPM	2.3	300 psi	50	350
7184, 7194, 7224, 7724	6 GPM	2.3	340 psi	50	500

Optimum performance of chemical injector occurs with a 35 ft. high pressure hose and a minimum 3/8 I.D. The type of hose, extended lengths, reduced I.D. and fittings may create back pressure in excess of the low pressure nozzle rating and prevent the injector from drawing chemical. **Deduct hose friction loss from the above PSI nozzle. Contact CAT PUMPS for assistance with other options.**

## TROUBLESHOOTING

No Chemical Draw:	<ul style="list-style-type: none"> <li>• Low pressure nozzle sized for too high pressure.</li> <li>• Air leak in suction line.</li> <li>• Worn injector orifice.</li> </ul>
Leaking Around Adjusting Collar:	<ul style="list-style-type: none"> <li>• O-ring worn.</li> <li>• Foreign material in injector.</li> </ul>

## WARRANTY

### 90 Day Warranty

Refer to complete CAT PUMPS Warranty for further information.

## World Headquarters

### CAT PUMPS

1681 - 94th Lane N.E. Minneapolis, MN 55449-4324

Phone (763) 780-5440 — FAX (763) 780-2958

e-mail: techsupport@catpumps.com

www.catpumps.com

## International Inquiries

FAX (763) 785-4329

e-mail: intlsales@catpumps.com



The Pumps with Nine Lives

## CAT PUMPS (U.K.) LTD.

1 Fleet Business Park, Sandy Lane, Church Crookham

FLEET, Hampshire, GU52 8BF, England

Phone Fleet 44 1252-622031 — Fax 44 1252-626655

e-mail: sales@catpumps.co.uk

## N.V. CAT PUMPS INTERNATIONAL S.A.

Heiveldekens 6A, B-2550 Kontich, Belgium

Phone 32-3-450.71.50 — Fax 32-3-450.71.51

e-mail: cpi@catpumps.be www.catpumps.be

## CAT PUMPS DEUTSCHLAND GmbH

Buchwiese 2, D-65510 Idstein, Germany

Phone 49 6126-9303 0 — Fax 49 6126-9303 33

e-mail: catpumps@t-online.de www.catpumps.de