



Pressure Regulator

Model 7085



FEATURES

- Provides system pressure setting and protection for single or multiple gun and pump systems.
- Compact size and easy installation.
- Immediately returns to system pressure when gun opens.

SPECIFICATIONS

	U.S. Measure	Metric Measure
Flow Range	1.0-3.5 GPM	(3.8-13.2 L/M)
Pressure Range.....	205-2300 PSI	(14-158 BAR)
Inlet Port.....	1/4" BSPM	(1/4" BSPM)
By-Pass Port [Internal]	1/8" BSPF	(1/8" BSPF)
By-Pass Port [External Hose Barb]	1/2"	(12.7 mm GH)
Maximum Temperature.....	195°F	(90°C)
Weight.....	4.8 oz.	(0.13 kg)
Dimensions	3.0 x 1.5 x 1.0" (76 x 38 x 25 mm)	

Regulator is stamped with a European safety pressure. Use only at above specifications to assure proper regulator life and performance.

⚠ WARNING

All systems require both a primary pressure regulating device (i.e., regulator, unloader) and a secondary pressure safety relief device (i.e., pop-off valve, safety valve). Failure to install such relief devices could result in personal injury or damage to the pump or to system components. CAT PUMPS does not assume any liability or responsibility for the operation of a customer's high pressure system.

SELECTION: This **pressure regulator** is designed for systems with **single or multiple** pumps, solenoid (gate) valves, nozzles, and standard or “weep” guns.

This regulator holds established system pressure in the discharge line when the trigger gun is closed or solenoid (gate) valve is closed or the nozzle is clogged, by-passing the unrequired flow. It returns to established system pressure without delay upon squeezing the trigger gun or opening the solenoid (gate) valve(s).

Select the specific model of regulator to meet both the desired system flow (combined nozzle flow rate requirement) and the desired system pressure.

Exercise caution when matching the system requirements to the regulator flow capacity and pressure rating. Operation below the minimum flow of the regulator causes the regulator to cycle, or chatter. Operation beyond the rated regulator flow causes premature valve wear, regulator cycling and prevents attaining desired system pressure.

Select a high pressure nozzle sized to provide for both the desired **system flow** and pressure and **regulator by-pass**.

CAUTION

A MINIMUM BY-PASS FLOW of 10% of the REGULATOR RATED FLOW CAPACITY is required for proper regulator performance.

When properly set this regulator protects the pump from pressure extremes associated with obstructions in the discharge line, while maintaining the established system pressure. When no flow is required by the system, the regulator by-passes all the system flow. Pressure is held in the discharge line [between the regulator and gun(s), solenoid valve(s) or nozzle(s)] **and the pump** head ready for a quick return to high pressure operation.

INSTALLATION: This regulator operates properly when mounted in any direction, however, it is preferred to keep the plumbing to a minimum and the adjusting cap easily accessible. The best location is teed directly from the pump discharge manifold head. Plumbing to and from the regulator should be at least the size of the regulator ports and flexible, high pressure hose (minimum single wire braid) is required.

The standard **inlet connection** is at the **side**. The regulator should be teed into the discharge manifold.

The **by-pass connection** is on the **bottom** of the regulator and connects to either a 1/2" hose or 1/8" BSP pipe. Note that prolonged by-pass can result in significant heat build-up and frequent by-pass can result in premature wear to the valve. A **MINIMUM BY-PASS OF 10%** is necessary for the regulator to operate properly.

CAUTION

If the entire output is directed through the regulator (zero by-pass) the “cushioning” feature of the by-pass liquid is eliminated and the regulator can malfunction or wear prematurely.

Check the amount of by-pass by disconnecting the by-pass line and measuring the flow into a graduated container.

By-Pass to Reservoir: Ideally the by-pass line should be directed to a reservoir with at least one baffle between the supply line to the pump (from the reservoir) and the return by-pass line (from the regulator into the reservoir). This baffle minimizes turbulence and air bubbles that could enter the pump inlet feed line. **The reservoir capacity should be 6-10 times the rated system flow per minute.**

By-Pass to Pump Inlet: Although not recommended, by-pass liquid can be returned to the inlet line of the pump or directly to a pump inlet port. When using this method an *Inlet Pressure Regulator* is recommended to protect the pump Lo-Pressure Seals from pressure spikes in the by-pass line. NOTE: By-Pass line pressure is typically less than 200 PSI. Be certain the Inlet Pressure Regulator is **between** the pump inlet and the by-pass line connection. When using this method, a *Thermo Valve* should be installed in the by-pass line to protect the pump from temperature build-up and premature seal failure.

The by-pass line should be **connected to the pump inlet line at a gentle angle of 45° or less and no closer than 10 times the pump inlet port diameter** e.g. 1-1/2" port size = 15" distance from pump inlet port. **Refer to Technical Bulletin 064 for additional information on the size and length of the by-pass line.**

By-Pass to Drain: If the by-pass is limited and infrequent, the by-pass can easily drain to an unpressurized drain line (to the ground).

TYPICAL INSTALLATION

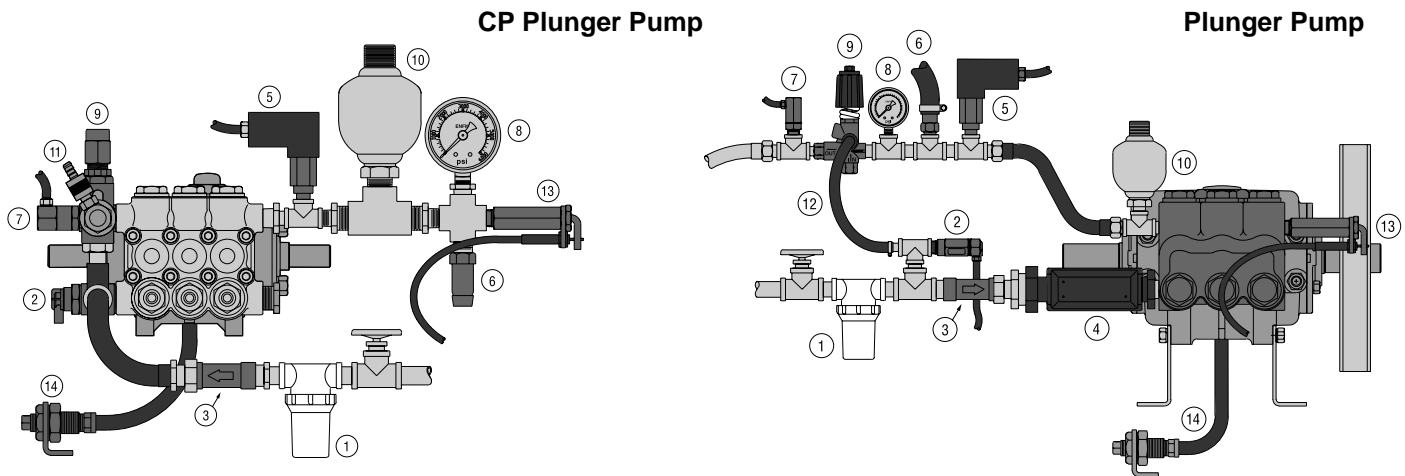

It is recommended that a secondary protective device such as the *CAT PUMP Pop-Off Valve* be installed to assure pump protection should the regulator malfunction. Refer to Troubleshooting for more information on malfunction of regulator.

Preferred mounting of the *Prrrrr-o-lator* (pulsation dampener) is directly **on the Discharge Manifold Head**. When using an *Inlet Pressure Regulator*, mount the *Prrrrr-o-lator* **downstream from the regulator** to assure optimum performance of the regulator.

PRESSURE ADJUSTMENT AS A REGULATOR: Setting and adjusting the regulator pressure must be done with the system "on". Start the system with the regulator backed off to the lowest pressure setting (**counterclockwise direction**). Squeeze the trigger and read the pressure on the gauge at the pump. **NOTE: Do not read the pressure at the gun or nozzle.** If more pressure is desired, release the trigger, turn adjusting cap one quarter turn in a **clockwise direction**. Squeeze the trigger and read the pressure. Repeat this process until desired system pressure is attained.

Once the desired system pressure is reached, stop turning the adjusting cap. Thread locking nut up to adjusting cap. **NOTE: The locking nut is not set at the factory.**

If desired system pressure cannot be reached, review TROUBLESHOOTING chart.

When servicing existing systems, back locking nut away from adjusting cap. Follow adjustment procedures as stated above for new regulators.

NOTE: Do not adjust regulator pressure setting to compensate for a worn nozzle. Check the nozzle as part of the regular maintenance and replace if worn.

SERVICE: The Regulator should be serviced on the same schedule as your pump. Replacing the O-rings is generally all that is required. Lubricate the O-rings for ease of installation and replace all O-rings included in the kit. Examine the seating surfaces and replace the seat or piston as required. Check the adjustment spring replace as needed. Thread the adjusting cap onto regulator and reset to system pressure. Set locking nut.

PRESSURE ADJUSTMENT AS A RELIEF VALVE: When the regulator is used as a secondary relief valve, adjust the pressure of the relief valve in the same increments as the primary valve, then adjust the relief valve to approximately 200 PSI above the primary valve pressure setting.

Approximate Pressure Reading at Gauge	Gauge Between Pump/Unloader	Gauge Between Unloader/Gun-Nozzle-Valve
System in operation (gun open)	system pressure	system pressure
System in by-pass (gun closed)	system pressure	system pressure

— TROUBLESHOOTING —

Cycling/Chattering	<ul style="list-style-type: none"> ● Too little flow for valve specifications. ● Air in system, poor connections. ● Inlet seals in pump worn. ● O-ring in gun worn.
System will not build up to pressure	<ul style="list-style-type: none"> ● Nozzle worn. ● Improper nozzle size for system specs.
Pressure drop	<ul style="list-style-type: none"> ● Nozzles worn. ● Piston and seat in regulator worn. ● Air in system, poor connections. ● Insufficient flow to pump. ● Filter clogged. Check and clean regularly.
Pressure spikes while in by-pass	<ul style="list-style-type: none"> ● Minimum by-pass of 10% not present. ● Excessive pressure adjustment made for worn nozzle. REPLACE NOZZLE. Reset system pressure.

— WARRANTY —

90 Day Warranty

Refer to complete CAT PUMPS Warranty for further information.

- | | |
|---|-------------------------------|
| 1 Inlet Filter | 8 Pressure Gauge |
| 2 Thermo Valve | 9 Pressure Regulator/Unloader |
| 3 Inlet Pressure Regulator | 10 Pulsation Dampener ★ |
| 4 C. A.T. Tube
(Captive Acceleration Tube) | 11 Chemical Injector |
| 5 Pressure Switch | 12 By-pass Hose |
| 6 Pop-Off Valve | 13 Throttle Controller |
| 7 Quick Start Valve | 14 Oil Drain Kit |

★ Preferred mounting of Pulsation Dampener [Prrrrr-O-Lator] is directly on the discharge manifold of the pump. The preferred mounting of the by-pass hose [when returning to the inlet] is before the Pressure Reducing Valve. If this is not possible, then mount the Prrrrr-O-Lator after the Pressure Unloading Valve to prevent pressure spikes to the pump inlet.

These illustrations show the basic elements for a typical installation of a high pressure piston or plunger pump. **Not all components shown are required for all applications or systems.** Each component presents potential problems that too often are ascribed to a perfectly functioning pump, such as: a clogged strainer, a partially closed shut-off valve, a faulty gauge, or a malfunctioning regulator/unloader. Proper system installation, routine lubrication, monitoring and maintenance of components are your basic guarantees of optimum pump performance. CAT PUMPS does not assume any liability or responsibility for the design or operation of a customer's high pressure system.

EXPLODED VIEW

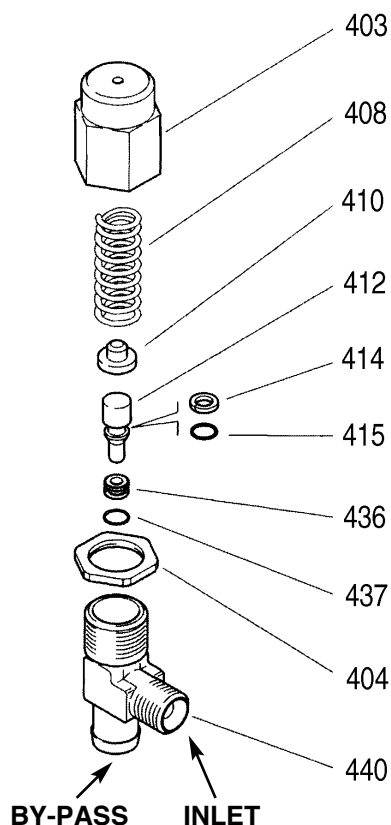

CUTAWAY

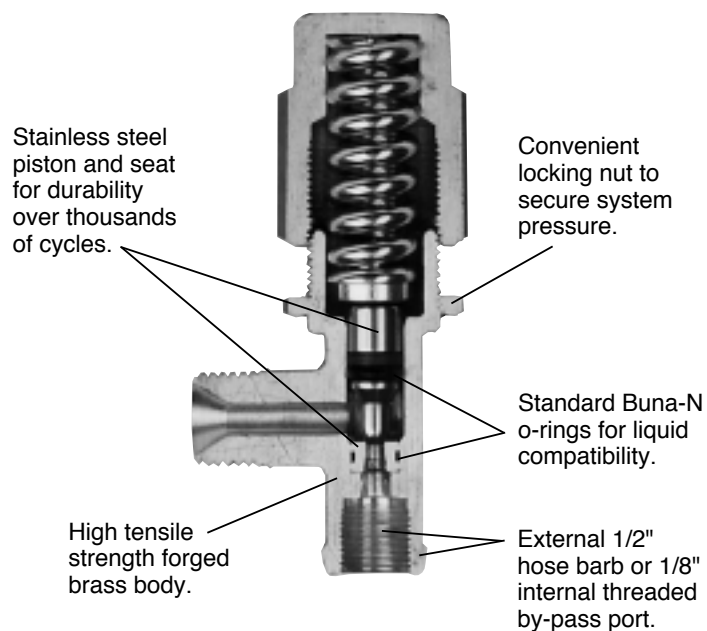

PARTS LIST

ITEM	PN	MATL	DESCRIPTION	QTY
403	33859	BB	Cap, Adjusting	1
404	31047	BB	Nut, Lock	1
408	33051	STL	Spring	1
410	32819	STZP	Retainer, Spring	1
412	33431	SSS	Piston	1
414	—	PTFE	Back-up-Ring, Piston	1
415	—	NBR	O-Ring, Piston	1
436	—	S	Seat	1
437	—	NBR	O-Ring, Seat	1
440	—	FBB	Body	1
468	33069	NBR	Kit, Repair (Inclds: 414, 415, 436, 437)	1

Italics are optional items.

MATERIAL CODES (Not Part of Part Number):

BB=Brass FBB=Forged Brass NBR=Medium Nitrile (Buna-N)

PTFE=Pure Polytetrafluoroethylene S=304SS SSS=416SS STL=Steel

STZP=Steel/Zinc Plated

World Headquarters

CAT PUMPS

1681 - 94th Lane N.E. Minneapolis, MN 55449-4324

Phone (763) 780-5440 — FAX (763) 780-2958

e-mail: techsupport@catpumps.com

www.catpumps.com

International Inquiries

FAX (763) 785-4329

e-mail: intlsales@catpumps.com



The Pumps with Nine Lives

CAT PUMPS (U.K.) LTD.

1 Fleet Business Park, Sandy Lane, Church Crookham, Fleet

Hampshire GU52 8BF, England

Phone Fleet 44 1252-622031 — Fax 44 1252-626655

e-mail: sales@catpumps.co.uk

N.V. CAT PUMPS INTERNATIONAL S.A.

Heiveldekens 6A, 2550 Kontich, Belgium

Phone 32-3-450.71.50 — Fax 32-3-450.71.51

e-mail: cpi@catpumps.be www.catpumps.be

CAT PUMPS DEUTSCHLAND GmbH

Buchwiese 2, D-65510 Idstein, Germany

Phone 49 6126-9303 0 — Fax 49 6126-9303 33

e-mail: catpumps@t-online.de www.catpumps.de