



7021-7033

7001-7003

7011-7014

FEATURES

- Conical piston and seat provide a consistently smooth flow that reduces wear and compensates for pressure spikes for extended valve life.
- Lightweight flow-through design for easy installation.
- Unique high velocity design assures consistent pressure for multiple pump or shut-off gun installations.
- Maintains full pressure while running in idle for quick return to system pressure.
- All metal wear parts are stainless steel; all elastomers are FPM for durability.
- Adjusting nut allows easy calibrated pressure adjustment.
- Multiple regulators can be installed in parallel to handle larger volumes.
- No external moving parts or springs.

⚠ CAUTIONS AND WARNINGS

All High Pressure Systems require a primary pressure regulating device (i.e. regulator, unloader) and a secondary pressure relief device (i.e. pop-off valve, relief valve). Failure to install such relief devices could result in personal injury or damage to pump or property. CAT PUMPS does not assume any liability or responsibility for the operation of a customer's high pressure system.

Read all CAUTIONS and WARNINGS before commencing service or operation of any high pressure system. The CAUTIONS and WARNINGS are included in each service manual and with each Accessory Data sheet. CAUTIONS and WARNINGS can also be viewed online at www.catpumps.com/cautions-warnings or can be requested directly from CAT PUMPS.

WARRANTY

View the Limited Warranty on-line at www.catpumps.com/warranty.

Pressure Regulator

Standard Models

7001-7033

Stainless Steel Models

7001.100-7033.100

SPECIFICATIONS

	U.S. Measure	Metric Measure
MODELS 7001, 7002, 7003 AND .100		
Flow Range.....	0.5-5.0 GPM	(1.9-19 l/m)
Pressure Range (7001).....	100-1000 PSI	(7-70 bar)
(7002).....	500-2000 PSI	(35-140 bar)
(7003).....	1500-3000 PSI	(105-210 bar)
Max. Temperature.....	180°F	(82°C)
Inlet/Outlet Port.....	3/8" NPTF	(3/8" NPTF)
By-Pass Port.....	1/2" NPTF	(1/2" NPTF)
Weight.....	2.25 lbs.	(1.02 kg)
Dimensions.....	6.25 x 1.5"	(159 x 38 mm)
MODELS 7011, 7012, 7013, 7014 AND .100		
Flow Range.....	1.0-10.0 GPM	(3.8-38 l/m)
Pressure Range (7011).....	100-1000 PSI	(7-70 bar)
(7012).....	500-2000 PSI	(35-140 bar)
(7013).....	1500-3000 PSI	(105-210 bar)
(7014).....	2000-4000 PSI	(140-275 bar)
Max. Temperature.....	180°F	(82°C)
Inlet/Outlet Port.....	1/2" NPTF	(1/2" NPTF)
By-Pass Port.....	3/4" NPTF	(3/4" NPTF)
Weight.....	3.75 lbs.	(1.70 kg)
Dimensions.....	7.5 x 1.88"	(191 x 48 mm)
MODELS 7021, 7022, 7023, 7024 AND .100		
Flow Range.....	2.5-25.0 GPM	(9.5-95 l/m)
Pressure Range (7021).....	100-1000 PSI	(7-70 bar)
(7022).....	500-2000 PSI	(35-140 bar)
(7023).....	1500-3000 PSI	(105-210 bar)
(7024).....	2000-4000 PSI	(140-275 bar)
Max. Temperature.....	180°F	(82°C)
Inlet/Outlet Port.....	3/4" NPTF	(3/4" NPTF)
By-Pass Port.....	1" NPTF	(1" NPTF)
Weight.....	5.0 lbs.	(2.40 kg)
Dimensions.....	8.5 x 2.25"	(216 x 57 mm)
MODELS 7031*, 7032, 7033 AND .100		
Flow Range.....	3.5-35 GPM	(13.2-133 l/m)
Pressure Range (7031).....	250-1000 PSI	(18-70 bar)
(7032).....	1000-2000 PSI	(70-140 bar)
(7033).....	1500-3000 PSI	(105-210 bar)
Max. Temperature.....	180°F	(82°C)
Inlet/Outlet Port.....	3/4" NPTF	(3/4" NPTF)
By-Pass Port.....	1" NPTF	(1" NPTF)
Weight.....	5.5 lbs.	(2.50 kg)
Dimensions.....	8.5 x 2.25"	(216 x 57 mm)

* Model 7031 replaces model 7028.

**Read all CAUTIONS and WARNINGS before commencing
service or operation of any high-pressure system**

SELECTION

This pressure regulator is designed for systems with single or multiple pumps, solenoid (gate) valves, nozzles, and standard or “weep” guns.

Note: For multiple pump systems, it is best to use a pressure regulator not a pressure sensitive regulating unloader.

This regulator should meet both the desired system flow (combined nozzle flow rate requirement) and the desired system pressure.

Note: Operation below the minimum flow of the regulator causes the regulator to cycle or chatter. Operation above the maximum flows of the regulator causes premature regulator wear, regulator cycling and prevents attaining desired system pressure.

INSTALLATION

This regulator operates properly when mounted in any direction; however, it is preferred to keep the plumbing to a minimum and the pressure adjusting nut easily accessible. The best mounting location is directly on the pump discharge manifold head. Flexible, high pressure hose (minimum single wire braid) should be at least the size of the regulator ports when plumbing to and from the regulator.

Since this is a flow through design regulator, the inlet and discharge connections are interchangeable and are located on the sides. An arrow on the label indicates liquid flow in either direction. Port size varies with each size of regulator (see specifications). Plumb into one side for inlet flow from pump and plumb opposite side to the discharge line with spray guns, solenoid (gate) valves or nozzles.

The by-pass connection of this regulator is located on the bottom. An arrow on the label indicates the direction of flow. Port size varies with each size of regulator (see specifications). By-pass liquid is directed out this port and can be routed to a reservoir (preferred method), or to a drain or back to the pump inlet.

OPERATION

This pressure regulator maintains established system pressure in the discharge line and at the pump head when the trigger gun is closed or solenoid (gate) valve is closed or the nozzle is clogged, thus by-passing all unrequired flow. Squeezing the trigger gun or opening the solenoid (gate) valve allows for a quick return to established system pressure without delay.

PRESSURE ADJUSTMENT

1. Setting and adjusting the regulator pressure must be done with the system “on”.
 2. Start the system with regulator backed off to the lowest pressure setting (counterclockwise direction).
 3. Squeeze the trigger and read the pressure on the gauge at the pump.
- Note:** Do not read the pressure at the gun or nozzle.
4. If more pressure is desired, release the trigger, turn brass adjusting nut one quarter turn in clockwise direction.
 5. Squeeze the trigger and read the pressure.
 6. Repeat this process until desired system pressure is attained.
 7. Once the desired system pressure is reached, stop turning the brass adjusting nut.

NOTICE: A minimum by-pass flow of 5% of the regulator rated flow capacity is required for proper regulator performance. If the entire output is directed through the regulator (zero by-pass) the “cushioning” feature of the by-pass liquid is eliminated and the regulator can malfunction or wear prematurely.

8. If desired system pressure cannot be reached, review TROUBLESHOOTING chart.
9. When servicing existing systems, back off adjusting nut.
10. Follow adjustment procedures as stated above.

Note: Do not adjust regulators pressure setting to compensate for a worn nozzle. Check the nozzle as part of the regular maintenance and replace if worn.

Note: A secondary pressure safety relief device (i.e. pop-off valve, safety valve) should be used along with this pressure regulator. Final adjustment for the relief valve should relieve at 200 psi above the system operating pressure.

TYPICAL REGULATOR INSTALLATION

- 1 Pressure Gauge
- 2 Relief Valve
Shown as a secondary safety relief valve
- 3 Pulsation Dampener
- 4 Pressure Regulator
- 5 Triplex Plunger Pump

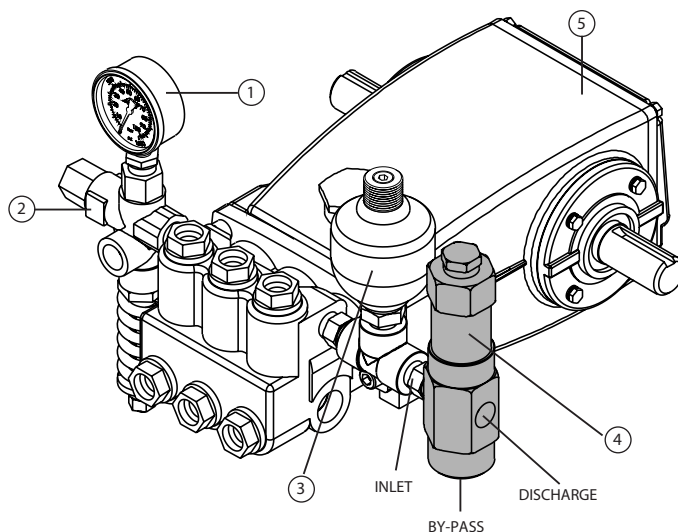

Read all CAUTIONS and WARNINGS before commencing service or operation of any high-pressure system

SERVICING

CAUTION: Before commencing with service, shut off drive (electric motor, gas or diesel engine) and turn off water supply to pump. Relieve all discharge line pressure by triggering gun or opening valve in discharge line.

Disassembly

1. Disconnect by-pass, discharge and inlet plumbing from regulator.
2. Remove regulator from pump.
3. Secure lower body of regulator in a vise with brass adjusting nut facing up.
4. Remove upper body by unthreading from lower body.
5. Grasp top of piston stem and separate from conical piston.
6. Remove piston stem with stack of spring washers, flat washers and anti-rotating washer and place on flat surface.
7. Remove conical piston with reverse pliers by making contact on the inside diameter of conical piston.

NOTICE: Exercise extreme caution to avoid contact and damage to outside diameter and sharp tip of conical piston.

8. Remove piston retainer from lower body of regulator.

NOTICE: Exercise extreme caution to avoid contact and damage to the inside diameter of the piston retainer.

9. Remove conical seat from lower body of regulator.

NOTICE: Exercise extreme caution to avoid contact and damage to outside diameter and the tapered surface of the seat.

Note: With the regulator completely disassembled, inspect lower body sealing areas where the conical seat and piston retainer makes contact for grooves, pitting and wear. If damage is found, replace with new lower body or complete new regulator. If not, proceed with reassembly.

Reassembly

Note: Conical piston and seat should be changed as a matched set when upgrading from the old tapered piston and seat. See Tech Bulletin 097.

Note: Spring washers and flat washers should be changed as a spring set. See Tech Bulletin 102.

1. Place lower regulator body with by-pass port facing down into a vise.
2. Lubricate and install o-ring onto outside diameter of conical seat. Press conical seat down into lower regulator body with small hole facing up.
3. Lubricate and install o-ring onto piston retainer. Press piston retainer with raised surface facing up.
4. Lubricate and install back-up-ring, then o-ring onto outside diameter of conical piston. Press conical piston with sharp point down into piston retainer.
5. Replace piston stem with stack of spring washers and flat washers into hole of conical piston.
6. Place anti-rotating washer on top of spring set. Align tabs on washer with slots on the upper body.

Note: The number of flat washers varies with each spring set. Place the first flat washer between the anti-rotating washer and spring stack. Place second washer (if required) between spring stack and retaining ring. Place all remaining washers with first washer.

7. Thread upper body into lower body.
8. Re-install regulator onto pump.
9. Reconnect by-pass, discharge and inlet plumbing to regulator.
10. Proceed to PRESSURE ADJUSTMENT.

TROUBLESHOOTING

- | | |
|-----------------------------------------------|-------------------------------------------------------------------------------------------------------------------------------------------------------------------------------------------------------------------------------------------------------------------------------------------------------|
| Cycling /Chattering | <ul style="list-style-type: none"> ● Too little flow for valve specifications. ● Air in system, poor connections. ● Inlet seals in pump worn. ● O-ring in gun worn. |
| System will not build up to pressure | <ul style="list-style-type: none"> ● Nozzle worn. ● Improper nozzle size for system specs. ● Foreign material trapped in seat. |
| Pressure drop | <ul style="list-style-type: none"> ● Nozzles worn. ● Piston and seat in regulator worn. ● Air in system, poor connections. ● Insufficient flow to pump. ● Filter clogged. Check and clean regularly. ● Fatigued or broken spring washers. |
| Pressure spikes while in by-pass | <ul style="list-style-type: none"> ● Minimum by-pass of 5% not present. ● Excessive pressure adjustment made for worn nozzle. REPLACE NOZZLE. Reset system pressure. |
| Leakage from regulator vent hole or top slots | <ul style="list-style-type: none"> ● O-ring around piston worn. Service with O-ring Kit. ● Piston Retainer scored. Service with O-ring kit and replace retainer. ● Fatigued or broken spring washers. |

Approximate Pressure Reading at Gauge	Gauge Between Pump/Regulator	Gauge Between Regulator/Gun-Nozz-Valve
System in operation (gun open)	system pressure	system pressure
System in by-pass (gun closed)	200-300 PSI above system pressure	200-300 PSI above system pressure

EXPLODED VIEW

(Models 7001, 7002, 7003 shown)

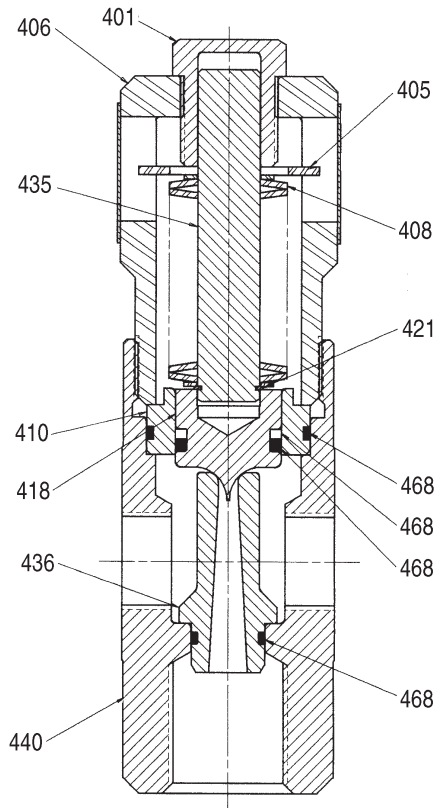

CUTAWAY

Convenient top adjusting nut for setting and adjusting system pressure.

Standard FPM O-Rings for maximum durability and compatibility.

Convenient inline mounting for compact easy installation.

External leaking from weep hole signals worn O-Rings and needed maintenance.

Hardened 316SS seat and piston for long life and thousands of cycles.

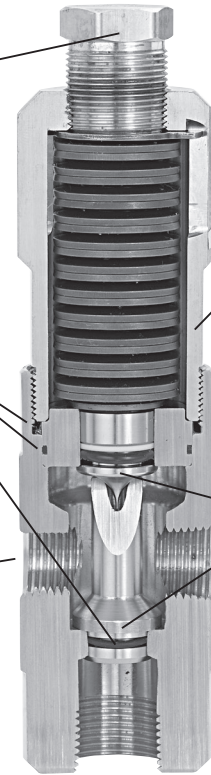

PARTS LIST

Item	Description	MATL	7001	7002	7003	7011	7012	7013	7014	7021	7022	7023	7024	7031	7032	7033
401	Nut, Adjusting	BB	30758	30758	30758	30759	30759	30759	30759	30760	30760	30760	30760	30760	30760	30760
405	Washer, Anti-Rot	STL	34491	34491	34491	34492	34492	34492	34492	34493	34493	34493	34493	34493	34493	34493
406	Body, Upper	STNP	—	—	—	—	—	—	—	—	—	—	—	—	—	—
408	Spring Set	STL	76201	76202	76202	76211	76212	76213	76214	76221	76222	76223	76224	76221	76222	76223
410	Retainer, Piston	SSS	30873	30873	30874	30875	30875	30876	30876	30877	30877	30878	30878	30877	30877	30878
	<i>Retainer, Piston (.100 Option)</i>	SS	33885	33885	33886	31635	31635	31666	31666	33877	33877	31878	31878	33877	33877	30878
418	Piston, Conical	SSB	31733	31733	31734	31738	31738	31739	31739	31743	31743	31744	31744	—	—	—
	Piston, Conical	SSSS R	—	—	—	—	—	—	—	—	—	—	—	31749	31749	31750
421	Ring, Retainer	STL R	30585	30585	30885	30886	30886	30886	30886	30887	30887	30887	30887	30887	30887	30887
435	Stem, Piston	STL	30588	30588	30888	30889	30889	30889	30889	30892	30892	30892	30892	30892	30892	30892
436	Seat, Conical	SSB	31732	31732	31732	31736	31736	31736	31736	31742	31742	31742	31742	—	—	—
	Seat, Conical	SSSS R	—	—	—	—	—	—	—	—	—	—	—	31748	31748	31748
440	Body, Lower	STNP R	—	—	—	—	—	—	—	—	—	—	—	—	—	—
	<i>Body, Lower (.100 Option)</i>	SS	—	—	—	—	—	—	—	—	—	—	—	—	—	—
468	Kit, O-Ring, Hex Body Style	FPM	30771	30771	30775	30777	30777	30781	30781	30783	30783	30787	30787	30783	30783	30787

For EPDM O-Ring Kits add .0220 to the FPM kit part numbers (i.e., 30771.0220)

It is recommended to replace spring washers and flat washers as a set.

Italics are optional items. See Tech Bulletins 022, 044,097 and 102 for additional information.

R components comply with RoHS Directive. Material Codes (Not Part of Part Number):

BB=Brass FPM=Fluorocarbon SS=316SS SSB=316SS Condition B SSS=416SS SSSS=440SS STNP=Steel/Nickel Plated STL=Steel

Contact CAT PUMPS for optional NBR or EPDM O-Ring Kits.



CAT PUMPS

1681 - 94TH LANE N.E. MINNEAPOLIS, MN 55449-4324

PHONE (763) 780-5440 — FAX (763) 780-2958

e-mail: techsupport@catpumps.com

www.catpumps.com