



Prrrrr-O-Lator Pulsation Dampeners

FEATURES

- Nitrogen precharged to eliminate moisture and bladder deterioration.
- Broader bladder design provides greater pulsation reduction for smoother performance and longer system component life.
- Optional 316 Stainless Steel and FPM construction for critical applications.
- New sealed style operates over full range of system pressures without precharge adjustment.

SHIPMENT REGULATIONS

- Pre-charged Prrrrr-O-Lators are defined as hazardous articles. Uncharged Prrrrr-O-Lators requires no special handling and can be shipped via standard shipping methods.
- All domestic shipments of hazardous articles must follow Department of Transportation CFR 49, parts 100 to 185 regulations (DOT).
- International shipments of hazardous articles must follow either International Air Transport Association regulation (IATA) or International Maritime Dangerous Goods Codes (IMDG).

⚠ CAUTIONS AND WARNINGS

All High Pressure Systems require a primary pressure regulating device (i.e. regulator, unloader) and a secondary pressure relief device (i.e. pop-off valve, relief valve). Failure to install such relief devices could result in personal injury or damage to pump or property. CAT PUMPS does not assume any liability or responsibility for the operation of a customer's high pressure system.

Read all CAUTIONS and WARNINGS before commencing service or operation of any high pressure system. The CAUTIONS and WARNINGS are included in each service manual and with each Data sheet. CAUTIONS and WARNINGS can also be viewed online at www.catpumps.com/cautions-warnings or can be requested directly from CAT PUMPS.

WARRANTY

View the Limited Warranty on-line at www.catpumps.com/warranty.

ORDERING INFORMATION

Use base part number for sealed models 6026 or 6028.

Use base part number for rechargeable models 6029,6030, or 6031 if factory pre-charge is desired.

Add .800 to base part number for rechargeable models (i.e. 6029.800) for:

1. No pre-charge (remove factory pressure)
2. A pre-charge different from factory (indicate desired pre-charge on purchase order)

Note: A handling charge will apply.

MODELS 6026 and 6028 - Sealed

	U.S. Measure	Metric Measure
Maximum Flow	15 GPM	(57 L/M)
Working Pressure Range (6026).....	300-600 PSI*	(20-41 BAR)
Working Pressure Range (6028).....	600-1000 PSI*	(41-70 BAR)
Precharge (6026 Sealed)	250 PSI	(17 BAR)
Precharge (6028 Sealed)	450 PSI	(32 BAR)
Operating Temperature Range.....	+5 to 180°F	(-20 to 82°C)
Volume	10 cu. in.	(0.16 L)
Safety Factor	4/1	(4/1)
Bladder Construction	NBR	(NBR)
Port Size	1/2" NPTM	(1/2" NPTM)
Diameter	2.93"	(74.5 mm)
Length	4.67"	(118.7 mm)
Weight	1.81 lbs.	(0.84 kg)

*Optimum pulsation dampening at stated PSI. If full dampening is not critical, performance is acceptable up to 3000 PSI system pressure.

MODELS 6029 and 6030 - Rechargeable

	U.S. Measure	Metric Measure
Maximum Flow	15 GPM	(57 L/M)
Working Pressure Range.....	100-3000 PSI	(7-210 BAR)
Precharge (Rechargeable).....	450 PSI	(32 BAR)
Operating Temperature Range.....	+5 to 180°F	(-20 to 82°C)
Volume	10 cu. in.	(0.16 L)
Safety Factor	4/1	(4/1)
Stainless Steel Lower Body.....	SS	SS
Bladder Construction (6029)	NBR	(NBR)
Bladder Construction (6030)	FPM	(FPM)
Port Size	1/2" NPTM	(1/2" NPTM)
Diameter	2.93"	(74.5 mm)
Length	5.51"	(140 mm)
Weight	2.18 lbs.	(1.02 kg)

MODEL 6031 - Rechargeable

	U.S. Measure	Metric Measure
Maximum Flow	15 GPM	(57 L/M)
Working Pressure Range.....	100-2400 PSI	(7-168 BAR)
Precharge (Rechargeable).....	450 PSI	(32 BAR)
Operating Temperature Range.....	+5 to 180°F	(-20 to 82°C)
Volume	10 cu. in.	(0.16 L)
Safety Factor	4/1	(4/1)
All Stainless Steel	SS	SS
Bladder Construction	NBR	(NBR)
Port Size	1/2" NPTM	(1/2" NPTM)
Diameter	2.93"	(74.5 mm)
Length	5.51"	(140 mm)
Weight	2.18 lbs.	(1.02 kg)

"Customer confidence is our greatest asset"

INSTALLATION INSTRUCTIONS

⚠ WARNING

Do not charge Prrrrr-O-Lators (Pulsation Dampeners) with oxygen. Oxygen may cause an explosion causing personal injury, death or property damage.

1. Use nitrogen only when charging pulsation dampeners, DO NOT USE OXYGEN.
2. Use proper charging tools to charge pulsation dampeners.
3. Charge pulsation dampener within specifications stated on data sheet to assure proper pulsation dampening and prevent failure of bladder.

SELECTION: The Prrrrr-O-Lator should be selected to match the flow and pressure requirements of the system and satisfy the liquid compatibility.

INSTALLATION: The Prrrrr-O-Lator should be mounted directly onto the pump discharge manifold for optimum pulsation dampening and to avoid system vibration damage.

OPERATION: The Prrrrr-O-Lator should be precharged with **dry Nitrogen only**.

The standard Prrrrr-O-Lator is precharged to 450 PSI, however, it may be adjusted to offer a more precise control of pulsation in critical applications such as reverse osmosis.

“Sealed” Prrrrr-O-Lators are preset at 250 or 450 PSI and are designed to operate over the full range of system pressures from 600 to 1000 PSI.

At a standard temperature of 70°F, optimum accumulator performance is obtained when the precharge is calibrated at 50% of the system operating pressure.

NOTE: When operating at the lower temperatures, precharge should be 15% higher or 65% of system pressure. When operating at higher temperatures, precharge should be 15% lower or 35% of system pressure.

This precharge should be checked every 12 months for normal operation and more frequently for continuous-duty operation.

NOTE: Up to 50 PSI precharge pressure can be lost during the checking of your precharge.

FILLING AND GAUGING INSTRUCTIONS

The following are the steps in both checking the precharge of the Prrrrr-O-Lator and recharging if there should be a loss of pressure or a need for adjustment.

NOTE: A gas regulator must be mounted between the nitrogen tank and the hose connection from the Filling and Gauging Assembly to enable you to regulate the precharge and to prevent excessive pressure being transmitted directly to the Prrrrr-O-Lator. **OVER PRESSURIZATION WILL VOID THE WARRANTY.**

1. Before checking your precharge, **system pressure should be at zero. TURN SYSTEM OFF.**
2. **SLIGHTLY** loosen the sealed valve at the top of the Prrrrr-O-Lator using a 6mm long handled allen wrench. Thread on the Filling and Gauging Assembly hand tight.
3. Be certain the **SIDE BLEED VALVE** on the gauging assembly is **CLOSED**.
4. Slowly open the **LARGE “T” VALVE** at the top of the gauging assembly until completely open. The gauge on the assembly will read the precharge on the Prrrrr-O-Lator.
5. Completely back off (**CLOSE**) the valve on the gas regulator, open the nitrogen tank valve and read the nitrogen tank pressure on the first gauge.
6. If the reading on the gauge assembly is 50% of the system pressure, close the top “T” valve and proceed to step 9.
7. If the precharge is too high, keep the top “T” valve open and slowly open the small “T” valve on the side of the gauging assembly to bleed of pressure.
8. If the pressure is less than 50% of the system pressure, slowly open the gas regulator valve until the desired precharge is reached on the second gauge.
9. When the gauge reads the required precharge, close the “T” valve on the top of the gauging assembly to lock the precharge in the Prrrrr-O-Lator.
10. Back off (**CLOSE**) the gas regulator.
11. Proceed with opening the small side “T” valve on the gauging assembly to relieve (bleed-off) pressure in the assembly and on the second gauge on the gas regulator.
12. Close the side “T” valve on the gauging assembly and remove the assembly from the Prrrrr-O-Lator.
13. Tighten the Prrrrr-O-Lator sealed valve and resume operation.

DIMENSIONAL

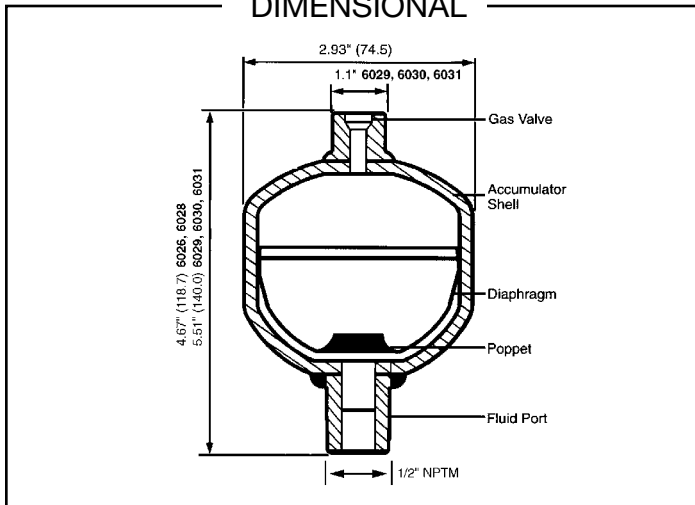

- 30940 Complete Filling and Gauging Assembly (Optional)
- 30941 Allen Wrench (Included in Assembly)
- 6099 Pressure Gauge (Included in Assembly)



World Headquarters

CAT PUMPS

1681 - 94th Lane N.E. Minneapolis, MN 55449-4324

Phone (763) 780-5440 — FAX (763) 780-2958

e-mail: techsupport@catpumps.com

www.catpumps.com

International Inquiries

FAX (763) 785-4329

e-mail: intlsales@catpumps.com



The Pumps with Nine Lives

CAT PUMPS (U.K.) LTD.

1 Fleet Business Park, Sandy Lane, Church Crookham

FLEET, Hampshire, GU52 8BF, England

Phone Fleet 44 1252-622031 — Fax 44 1252-626655

e-mail: sales@catpumps.co.uk www.catpumps.co.uk

N.V. CAT PUMPS INTERNATIONAL S.A.

Heiveldekens 6A, B-2550 Kontich, Belgium

Phone 32-3-450.71.50 — Fax 32-3-450.71.51

e-mail: cpi@catpumps.be www.catpumps.be

CAT PUMPS DEUTSCHLAND GmbH

Buchwiese 2, D-65510 Idstein, Germany

Phone 49 6126-9303 0 — Fax 49 6126-9303 33

e-mail: catpumps@t-online.de www.catpumps.de