

FEATURES

- Pushing the MAG-JET handle activates the jetting action and pulling returns the pump smoothly to full flow high pressure operation.
- Special SS magnetic valve and super strong corrosion resistant magnet hold one inlet valve open for pulsing action. Holding the valve open permits the flow to continue to exit through the valve eliminating a dry cylinder.
- All cylinders see liquid at all times and pump is not exposed to extreme vacuum conditions. This means longer seal and pump life!
- MAG-JET easily mounts in the manifold inlet plug on most models for easy field-retrofit.
- Optional sewer jetting hose and nozzle kits available for select models.

SELECTION: The MAG-JET Valve is designed for a specific pump or group of pumps and conveniently mounts into any of the standard inlet valve plug ports.

Due to its stacked valve design, plunger pump model 3560 cannot be retrofitted in the field. The discharge manifold must be machined in order to add the MAG-JET feature. To convert to 3560J, order Stem and Valve Kit PN 899910.

INSTALLATION: To convert from high pressure to jetting, remove the standard inlet valve plug and valve assembly from any inlet valve chamber of your choosing. To install the MAG-JET Valve, first insert the pre-assembled MAG-JET valve assembly (items 162-168) and press completely into the valve chamber. Then thread the MAG-JET body and handle

MAG-JET Valve for Jetting/Pulsating

Patent Pending

Model 31804

Use With Pump Models:

3CP1120, 3CP1120G, 3CP1130, 3CP1140

Model 31805

Use With Pump Models:

66DX30G1I, 66DX35G1I, 66DX40G1I

Model 31810

Use With Pump Models:

56, 56G1, 57, 59, 59G1, 60, 60G1

Model 31814

Use With Pump Models:

310, 340, 34G1, 350, 35G1

5CP2120W, 5CP2140WCS, 5CP2150W

Model 31815

Use With Pump Models:

45, 5CP3120, 5CP3120G1, 5CP5120, 5CP5150G1

Model 31845

Use With Pump Models:

53, 58G1, 55, 51G1, 660, 1050, 5CP6120, 7CP6170

assembly (items 169-195) into the valve chamber and torque to specifications (see Tech Bulletin 074 or individual pump data sheet).

OPERATION: Release the trigger on the gun to activate the by-pass mode, push in the handle to activate the magnet that holds open the inlet valve and start the jetting action. On the model 3560J the inlet valve is held open by the detent when the MAG-JET is pushed in. Pull out the handle to return to full flow high pressure cleaning mode. **NOTE:** When in jetting mode, pump output is reduced by 1/3 and discharge pressure will drop.

“Customer confidence is our greatest asset”

EXPLODED VIEW

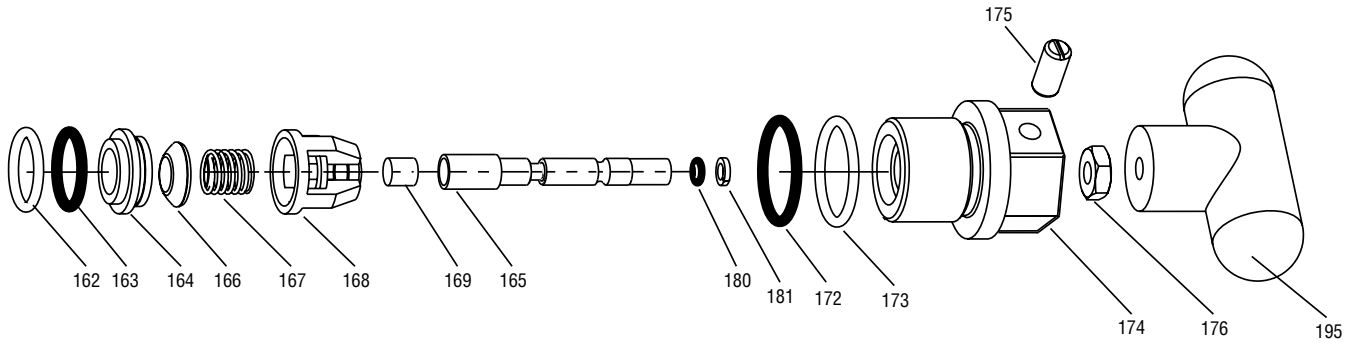

PARTS LIST

ITEM	MATL	DESCRIPTION	MAG-JET VALVE						QTY
			31804	31805	31810	31814	31815	31845	
162	PTFE	Back-up-Ring, Seat	N/A	N/A	43248	—	N/A	43248	1
	D	Back-up-Ring, Seat	N/A	N/A	—	48361	N/A	—	1
163	NBR	O-Ring, Seat	17547	17547	43249	43358	17547	43249	1
164	S	Seat, Inlet	45790	45790	43722	43725	45790	44718	1
165	S	Stem	899926	899926	899935	899926	899926	899938	1
166	SSSS	Valve, Magnet	899929*	899929*	899937*	899929*	899929*	899937*	1
167	S	Spring	43750	43750	43751	43750	43750	43751	1
168	PVDF	Retainer, Valve	899928	899928	899936	899928	899928	899940	1
169	CP	Magnet (1/4"x1/4")	899923	899923	899923	899923	899923	—	1
	CP	Magnet (3/8"x3/8")	—	—	—	—	—	899939	1
172	NBR	O-Ring, Valve Plug	17615	17616	14179	17615	17549	17617	1
173	PTFE	Back-up-Ring, Valve Plug	N/A	N/A	20213	N/A	—	N/A	1
	D	Back-up-Ring, Valve Plug	N/A	N/A	—	N/A	48365	N/A	1
174	BB	Body, Valve Plug	899930	899924	899931	899930	899933	899934	1
175	S	Detent Assembly	899925	899925	899925	899925	899925	899925	1
176	STZP	Nut, Jam (1/4"-20)	899927	899927	899927	899927	899927	899927	1
180	NBR	O-Ring, Stem - 70D	899921	899921	899921	899921	899921	899921	1
181	PTFE	Back-up-Ring, Stem	899922	899922	899922	899922	899922	899922	1
195	POP	Handle, Jetter	899920	899920	899920	899920	899920	899920	1
310	—	Kit, Stem and Valve	899904	899905	899906	899907	899908	899909	1

(Incls: 162-169, 172, 173, 180, 181)

*NOTE: Special Magnetic Valve used in MAG-JET assembly. Do not use standard valve from Valve Kits.

Bold print part numbers are unique to a particular pump model. Italics are optional items.

MATERIAL CODES (Not Part of Part Number): BB=Brass CP=Chrome Plated D=Acetal NBR=Medium Nitrile (Buna-N) PTFE=Pure Polytetrafluoroethylene POP=Polypropylene PVDF=Polyvinylidene Fluoride S=304SS SSSS=440SS STZP=Steel/Zinc Plated

TROUBLESHOOTING

- | | |
|-------------------------------|---|
| Won't Pulsate | • Secure detent assembly setting thread in and back off 1/8 turn. |
| Leaking at Stem | • Worn O-Ring on stem.
• Check all valves and repair as needed. |
| Won't resume to High Pressure | • Check jetter valve and seat for damage or trapped debris and replace as needed with stem and valve kit. |

⚠ WARNING

Severe injury can occur with high pressure spray.
Do not allow spray to contact any part of body.

WARRANTY

90 Day Warranty

Refer to complete CAT PUMPS Warranty for further information.

World Headquarters

CAT PUMPS

1681 - 94th Lane N.E. Minneapolis, MN 55449-4324

Phone (763) 780-5440 — FAX (763) 780-2958

e-mail: techsupport@catpumps.com

www.catpumps.com

International Inquiries

FAX (763) 785-4329

e-mail: intlsales@catpumps.com



The Pumps with Nine Lives

CAT PUMPS (U.K.) LTD.

1 Fleet Business Park, Sandy Lane, Church Crookham

FLEET, Hampshire, GU52 8BF, England

Phone Fleet 44 1252-622031 — Fax 44 1252-626655

e-mail: sales@catpumps.co.uk

N.V. CAT PUMPS INTERNATIONAL S.A.

Heiveldekens 6A, B-2550 Kontich, Belgium

Phone 32-3-450.71.50 — Fax 32-3-450.71.51

e-mail: cpi@catpumps.be www.catpumps.be

CAT PUMPS DEUTSCHLAND GmbH

Buchwiese 2, D-65510 Idstein, Germany

Phone 49 6126-9303 0 — Fax 49 6126-9303 33

e-mail: catpumps@t-online.de www.catpumps.de