



Industrial Wet Sandblaster

Model **30667**
Includes 35150 Gun Handle

Model **30677**
Includes 31250 Gun Handle

FEATURES

- Lightweight aluminum housing for ease in handling.
- High efficiency venturi design for wide range of operating pressures and flows.
- Tungsten carbide mixing nozzle for maximum service life.
- Quality construction for ultimate performance.
- Draws up to 1000 pounds of sand per hour.
- Reinforced sand induction hose for restriction-free sand flow.

INSTALLATION: For best results the sand unit should be connected to a quality high pressure water source. A pressure gauge should be installed on the system. Performance of the sand unit is directly affected by the pressure of the system. Make certain all necessary sand and water hose connections are airtight. A regulator or unloader must be installed in the pump discharge line of any system with a shut-off gun.

⚠ WARNING

Due to the severe abrasive action of high velocity water and sand, adequate eye protection, clothing and safety equipment must be worn during operation of the wet sandblaster. Do not allow spray to contact the body or point nozzle in the direction of any person.

SPECIFICATIONS

	U.S. Measure	Metric Measure
MODEL 30667		
Maximum Flow	6.1 GPM	(38 L/M)
Maximum Pressure.....	3000 PSI	(210 BAR)
Maximum Temperature.....	160°F	(71°C)
Weight.....	4.75 lbs.	(2.15 kg)
Wand Length.....	30"	(762 mm)
Overall Length.....	41"	(1041 mm)
MODEL 30677		
Maximum Flow	8 GPM	(76 L/M)
Maximum Pressure.....	5500 PSI	(380 BAR)
Maximum Temperature.....	160°F	(71°C)
Weight.....	7.87 lbs.	(3.57 kg)
Wand Length (part of 31250 Gun)	15.74"	(400 mm)
Overall Length.....	31.5"	(800 mm)

OPERATION: Start the high pressure system and adjust the water flow and system pressure with your nozzle selection, pump RPM and Regulating Unloader setting. Open the trigger on gun to assure system is operating properly.

Place the sand induction probe in the sand supply container. With the trigger on the gun open, adjust the small valve on the mixing line and starts the flow of sand. The sandblaster will be approximately 12 to 15 inches away from the work surface when the trigger is opened and the wet sandblasting operation begins. **NOTE: Test a sample area to be certain the surface will not be damaged by abrasive action.**

continued on back

“Customer confidence is our greatest asset”

EXPLODED VIEW

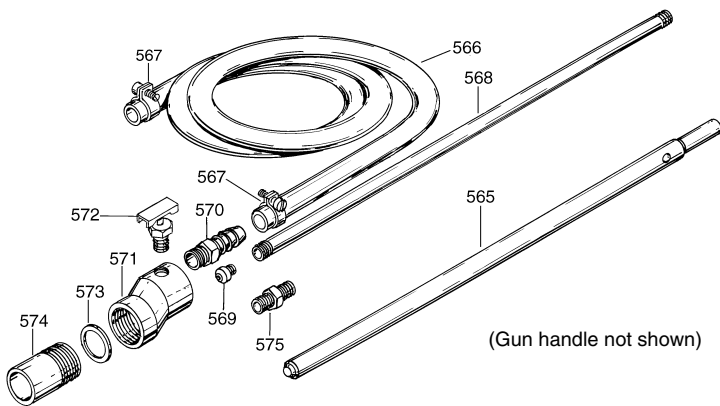

PARTS LIST

ITEM	P/N	MATL	DESCRIPTION	QTY
565	30672	STZP	Probe, Sand Induction	1
566	30681		Hose, Sand Inlet (12.5 Feet)	1
567	30682	STZP	Clamps, Hose	2
568	30675	STZP	Tube, Water Inlet (1/4" NPT, 3000 PSI) (USE ONLY WITH 1/4" 35150 GUN)	1
569	30674	SS	Nozzle, Spray (7.0-5")	1
570	30679	BB	Barb, Sand Hose (1/2" NPTM)	1
571	—	AL	Housing	1
572	30670	BB	Cock, Drain	1
573	30669	NE	Gasket, Mixing Nozzle	1
574	30668	NYTC	Nozzle, Mixing w/Gasket	1
575	30678	STZP	Adapter (5500 PSI) (USE ONLY WITH 31250 GUN)	1
—	30415		<i>Assembly, Housing</i> (Incls: 570, 571, 572, 573, 574)	1
—	30414		<i>Assembly, Head and Probe</i> (Incls: 565, 569, 570, 571, 572, 573, 574)	1

Italics are optional items.

MATERIAL CODES (Not Part of Part Number): AL=Aluminum BB=Brass
NE=Neoprene SS=316SS STZP=Steel/Zinc Plated NYTC=Nylon/Tungsten Carbide

TROUBLESHOOTING

No Sand:

- Plugged sand probe
- Wet sand
- Low vacuum
- Clear obstruction in sand probe.
- Remove mixing nozzle and inspect mixing chamber.
- Dry or replace sand.
- Check for air leak in system.

Not enough sand:

- Low water pressure
- Collapsed hose
- Hot water reduces efficiency
- Partially plugged sand probe
- Restricted sand flow
- Check water supply to pump, nozzle size and RPM of pump.
- Use reinforced hose. Remove any obstruction.
- Optimum performance obtained with cold water.
- Remove any restriction from sand probe inlet. Use dry sand.
- Increase diameter of hose. Recommend 1/2" ID, maximum 25 ft.

OPERATION: (continued) The angle of attack and distance from the work surface may be varied to provide the best work speed while still maintaining the greatest amount of impact energy. For optimum performance the sand inlet hose should not exceed 25 feet.

When the sand unit is operating efficiently, there will be a smooth and continuous flow of sand through the nozzle. The amount of sand flow is directly related to the vacuum created in the mixing nozzle. The intensity of the vacuum is dependent upon the liquid velocity of the water.

The pressure and flow rate through the spray nozzle are the factors that determine the liquid velocity, amount of vacuum and rate of sand flow.

Wet sandblasting is normally done with ambient temperatures. Use of elevated temperatures can reduce the overall impact.

If the spray nozzle is chosen to give the maximum pressure and flow rate possible for the pump, the rate of sand flow will also be at maximum. Total vacuum seal and maximum swirl velocity are obtained with a 5° spray nozzle.

Vacuum readings are obtained in the mixing chamber. At least 10 to 15 inches of vacuum is developed in the mixing chamber when the wet sandblaster is working properly. Most efficient operation of the wet sandblaster is with maximum vacuum in the mixing chamber and no restriction in the sand flow.

SERVICING: Spray nozzle replacement is made by removing the mixing nozzle. The assembly should be thoroughly cleaned of sand to prevent damage to the threads and clogging of the nozzle. A 1/2" socket can be used to remove the spray nozzle. Install a new spray nozzle. Tighten the nozzle until the spray pattern is horizontal.

FLOW CHART

Approximate Water Flows at Shown Pressures Calculated
Using Standard 30674 Spray Nozzle

500 PSI2.5	GPM
1000 PSI3.5	GPM
1500 PSI4.3	GPM
2000 PSI5.0	GPM
2500 PSI5.6	GPM
3000 PSI6.1	GPM
5000 PSI7.8	GPM

SAND SUPPLY

SURFACE	SUGGESTED SAND TYPE
Rust	Angular 16-50
Metal Scale	Round 20-40
Painted Metal	Round Silica 20-40
Painted Masonry	Round River 20-40
Painted Wood	Round 20-40

WARRANTY

90 Day Warranty

Refer to complete CAT PUMPS Warranty for further information.

World Headquarters

CAT PUMPS

1681 - 94th Lane N.E. Minneapolis, MN 55449-4324

Phone (763) 780-5440 — FAX (763) 780-2958

e-mail: sales@catpumps.com

www.catpumps.com

International Inquiries

FAX (763) 785-4329

e-mail: intlsales@catpumps.com



The Pumps with Nine Lives

CAT PUMPS (U.K.) LTD.

1 Fleet Business Park, Sandy Lane, Church Crookham, Fleet

Hampshire GU52 8BF, England

Phone Fleet 44 1252-622031 — Fax 44 1252-626655

e-mail: sales@catpumps.co.uk

N.V. CAT PUMPS INTERNATIONAL S.A.

Heiveldekens 6A, 2550 Kontich, Belgium

Phone 32-3-450.71.50 — Fax 32-3-450.71.51

e-mail: cpi@catpumps.be www.catpumps.be

CAT PUMPS DEUTSCHLAND GmbH

Buchwiese 2, D-65510 Idstein, Germany

Phone 49 6126-9303 0 — Fax 49 6126-9303 33

e-mail: catpumps@t-online.de www.catpumps.de