

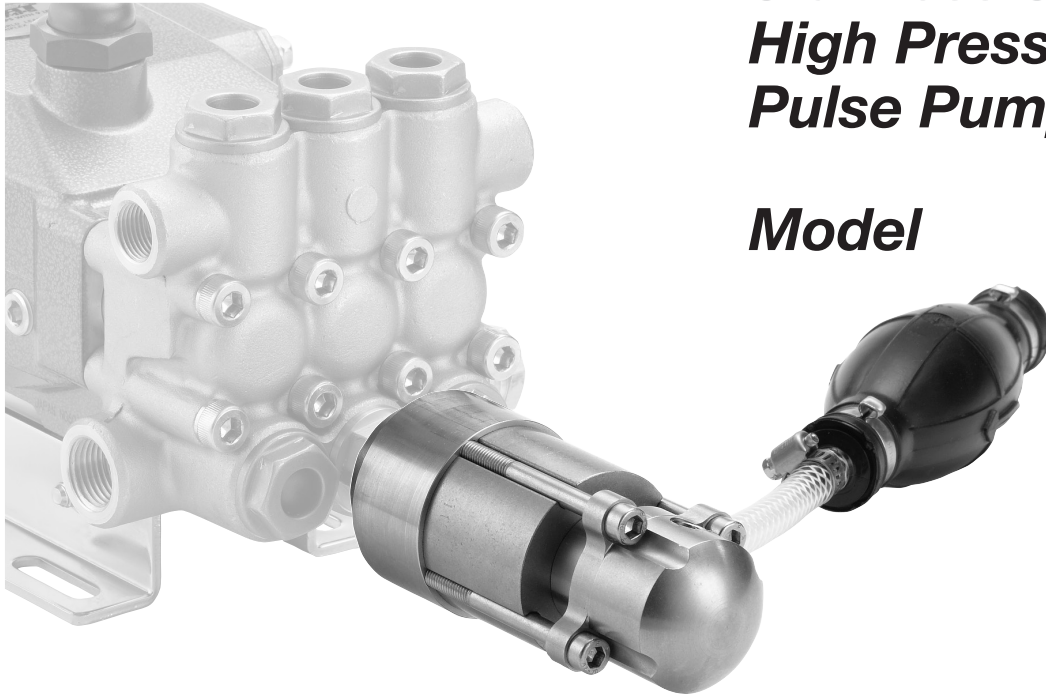

Stainless Steel High Pressure Pulse Pump

Model

6350



FEATURES

- Permits chemical application up to 3000 PSI.
- Eliminates pumping harsh chemicals through the main pump.
- Conveniently mounts with an adapter into the center inlet valve chamber on the main pump.
- Standard prime bulb with check valve to initiate chemical flow.

SPECIFICATIONS

	U.S. Measure	Metric Measure
Pressure Range	500 to 3000 PSI	(35 to 210 BAR)
Flow Range	1 to 12 GPH	(3.7 to 45.4 LPH)
RPM Range	300 to 1800 RPM	(300 to 1800 RPM)
Maximum Liquid Temperature.....	130°F	(54°C)
Inlet Port (1)	1/4" Hose Barb	(1/4" Hose Barb)
Discharge Port (1).....	1/8" NPTF	(1/8" NPTF)
Weight (w/o Adapter Assy).....	2.9 lbs.	(13.15 kg)
Diameter	2"	(50.8 mm)
Length	5"	(127 mm)

⚠ CAUTIONS AND WARNINGS

All High Pressure Systems require a primary pressure regulating device (i.e. regulator, unloader) and a secondary pressure relief device (i.e. pop-off valve, relief valve). Failure to install such relief devices could result in personal injury or damage to pump or property. CAT PUMPS does not assume any liability or responsibility for the operation of a customer's high pressure system.

Read all CAUTIONS and WARNINGS before commencing service or operation of any high pressure system. The CAUTIONS and WARNINGS are included in each service manual and with each Accessory Data sheet. CAUTIONS and WARNINGS can also be viewed online at www.catpumps.com/cautions-warnings or can be requested directly from CAT PUMPS.

WARRANTY

View the Limited Warranty on-line at www.catpumps.com/warranty.

Injection Rate

Pump RPM	Injection Rate	Pump RPM	Injection Rate
300	3.0 GPH	1100.....	11.0 GPH
400.....	4.0 GPH	1200.....	12.0 GPH
500.....	5.0 GPH	1300.....	12.0 GPH
600.....	6.0 GPH	1400.....	12.0 GPH
700.....	7.0 GPH	1500.....	12.0 GPH
800.....	8.0 GPH	1600.....	12.0 GPH
900.....	9.0 GPH	1700.....	12.0 GPH
1000	10.0 GPH	1800.....	12.0 GPH

"Customer confidence is our greatest asset"

SELECTION

Select proper adapter assembly to match the appropriate pump model.

Pump Models	Adapter Assembly
335, 435, 625, 825, 1015.....	76400
3CP1120, 3CP1130, 3CP1140.....	76405
310, 340, 350, 5CP2120W, 5CP2140WCS, 5CP2150W.....	76405
45, 5CP3120, 5CP5120, 5CP5140, 5CP5150.....	76410
530, 550.....	76415
660, 1050.....	76415
5CP6120.....	76415
7CP6110, 7CP6170.....	76415

INSTALLATION

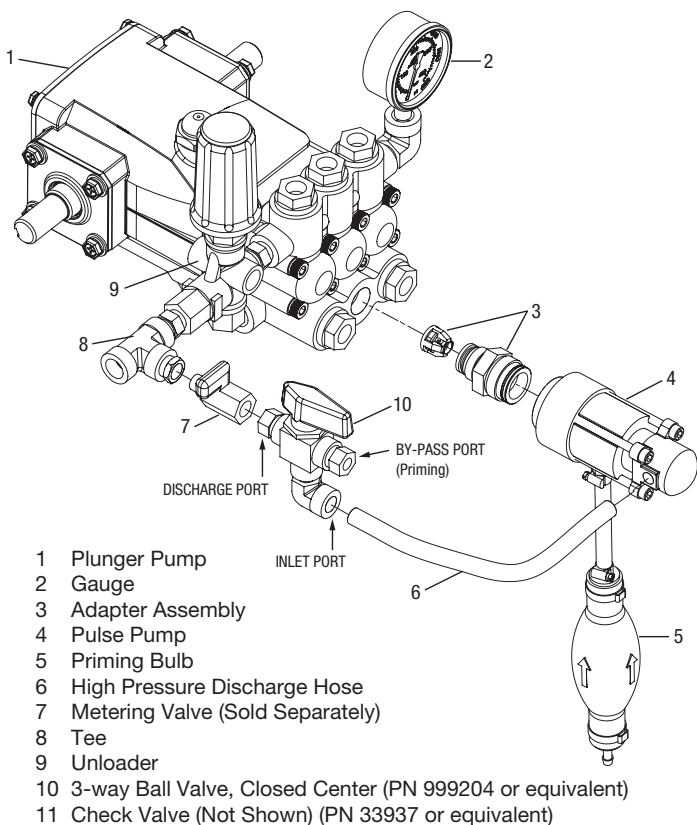

Plunger Pump Conversion

1. Remove center inlet valve plug from discharge manifold.
2. Remove complete valve assembly from valve chamber.
3. Separate spring retainer from valve seat.
4. Install modified spring retainer from adapter assembly onto valve seat.
5. Install modified valve assembly into center inlet valve chamber.
6. Lubricate and install new valve plug o-ring around small end of adapter body. Lubricate and install new backup-ring and then new o-ring around larger end of adapter body.
7. Thread adapter assembly into valve chamber and torque to 870 in-lbs.
8. Apply Loctite®242® to exposed threads of adapter assembly. Thread pulse pump onto adapter assembly and position pulse pump so that 1/4"NPT barb is in desired position.
9. Attach priming bulb with hose to 1/4"NPT barb on pulse pump.
10. Attach any standard high pressure hose from 1/8"NPT port on pulse pump to a metering valve after the unloader.

Piston Pump Conversion

1. Remove discharge manifold from the piston pump.
2. Replace with new pulse pump manifold and associated parts, and a new flat valve kit.
3. Place pulse pump manifold with three cylinder holes facing upwards.
4. In the cylinder hole with the deeper counterbore, install one white PTFE seal washer and one spring retainer (without nylon insert).
5. Install heavy duty spring, standard flat valve spring, flat valve, flat seat and spacer into this same deep cylinder hole.
6. In the remaining two cylinder holes, first install one white PTFE seal washer and then a complete flat valve assembly.
7. Remove existing shims from each cylinder bolt. Since the number of shims may change with the manifold, refer to Tech Bulletin 017 for proper shimming procedure and mount pulse pump manifold to pump.
8. Lubricate and install backup-ring and then o-ring on adapter assembly.
9. Thread adapter assembly into special 1/2"NPTF port on the top of the pulse pump manifold.
10. Apply Loctite®242® to exposed threads of adapter assembly. Thread pulse pump into adapter assembly and position pulse pump so that 1/4" NPT barb is in desired position.
11. Attach priming bulb with hose to 1/4"NPT barb on pulse pump.
12. Attach any standard high pressure hose from 1/8"NPT port on pulse pump to a metering valve after the unloader.

OPERATION

NOTE: A metering valve and closed center 3-way ball valve are required to properly operate the pulse pump.

1. Ensure pump is connected to a water supply but is NOT running.
 2. Open 3-way ball valve (PN 999204 or equivalent) to by-pass port.
 3. Squeeze priming bulb repeatedly until chemical flows through the pulse pump and comes out the by-pass port of 3-way ball valve.
 4. Turn water supply on, open trigger gun and start up pump.
 5. Bring pump up to operating pressure and set regulating devices.
- Note:** Main pump inlet pressure must not exceed 20 psi.
6. Allow chemical to flow out of by-pass port of 3-way ball valve, then switch 3-way ball valve to discharge port.
 7. Adjust metering valve to the desired amount of chemical/water mixture.

Note: Optional check valve (PN 33937) can be located at pulse pump inlet to avoid any back flow to chemical supply as High Pressure Seal assembly wears.

Note: Priming bulb can be eliminated if chemical is gravity fed.

TROUBLESHOOTING

No chemical supply from pulse pump

- Air in chemical supply line.
- Foreign material in inlet or discharge valves of drive pump.
- Foreign material in inlet or discharge valves of pulse pump.
- System not properly primed.

Limited chemical supply from pulse pump

- Worn inlet and discharge valves.
- Restriction in metering hose.
- Restriction between drive pump and pulse pump.

EXPLODED VIEW

6350 PULSE PUMP

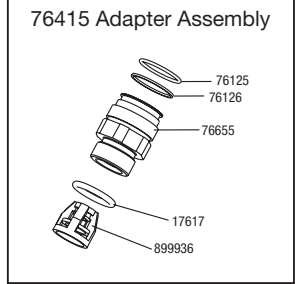
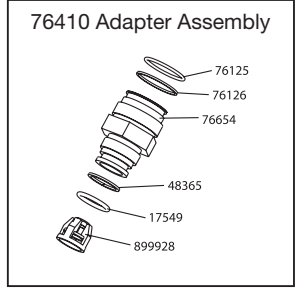
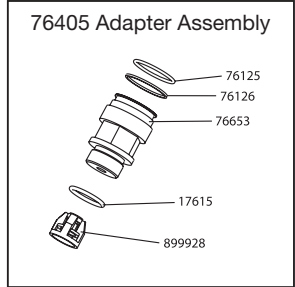
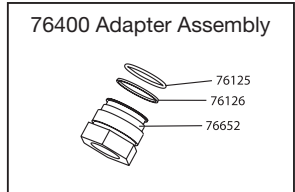
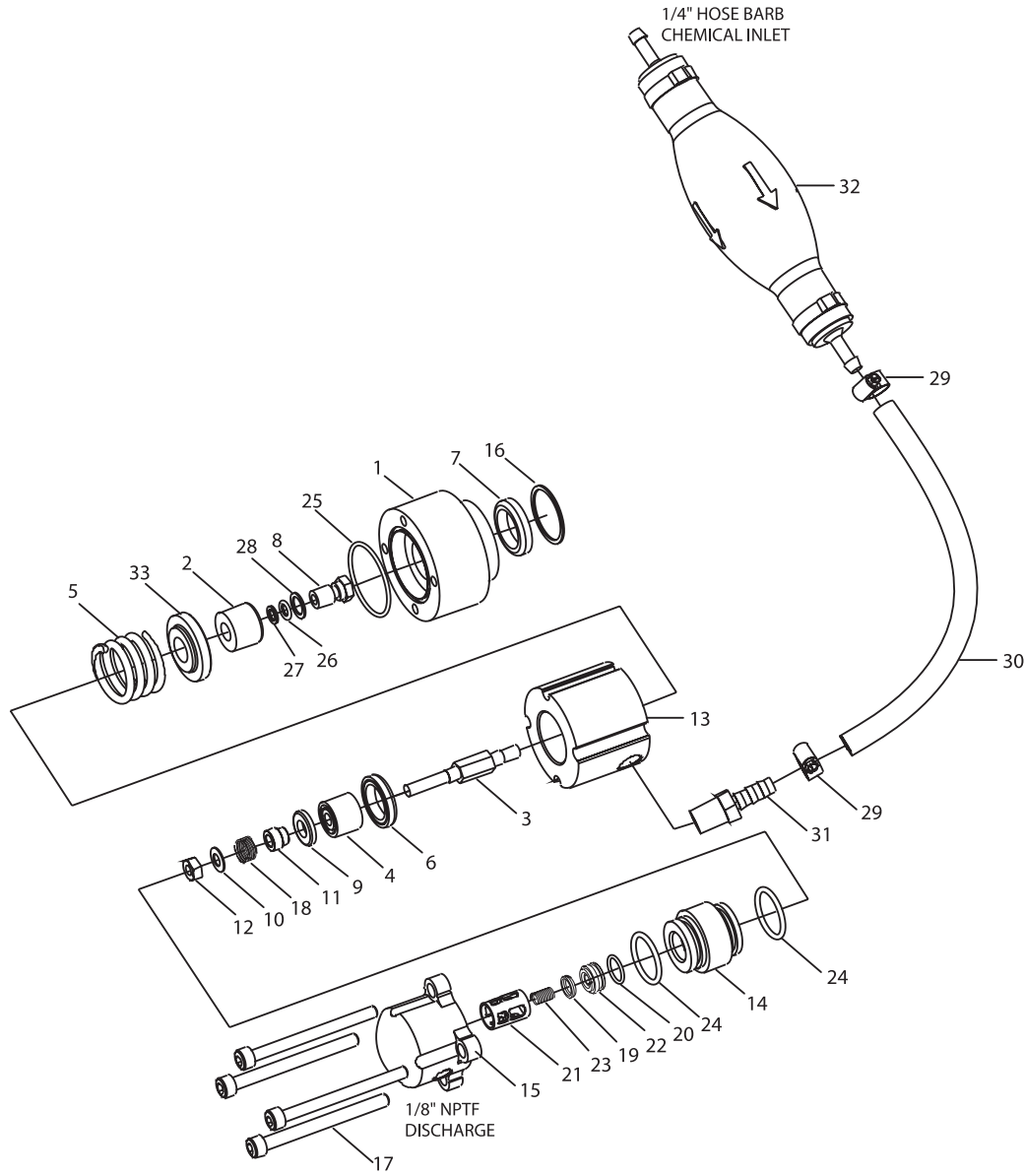

PARTS LIST

ITEM	PN	MATL	DESCRIPTION	QTY	ITEM	PN	MATL	DESCRIPTION	QTY
1	—	S	Body, Pulse	1	24	11377	FPM	O-Ring - 80D	2
2	49449	CC	Plunger (M20x15.4)	1	25	76113	FPM	O-Ring, Body - 75D	1
3	76139	S	Rod, Plunger	1	26	17399	NBR	O-Ring - 80D	1
4	45847	CC	Plunger (M18X14)	1	27	43235	PTFE	Back-up-Ring	1
5	76107	SS	Spring, Return	1	28	44041	SS	Gasket	1
6	46652	HT*	Seal Assy, HPS	1	29	76339	S	Clamp, Hose 1/4"	2
7	46667	HT*	Seal Assy, HPS	1	30	76268	PVC	Tubing 1/4"x4"	1
8	46504	S	Retainer, Plunger	1	31	76651	S	Barb, Hose 1/4"	1
9	33873	NY	Valve, Inlet	1	32	76649	RBR	Bulb, Priming w/Check Valve	1
10	88575	S	Washer, Conical (M6)	1	33	76109	SS	Retainer, Stroke	1
11	549520	S	Spacer, Inlet	1	<i>76400</i>	—	<i>Assembly, Adapter</i>	<i>1</i>	
12	81240	S	Nut, Hex (M6)	1	<i>76405</i>	—	<i>Assembly, Adapter</i>	<i>1</i>	
13	—	S	Body, Inlet	1	<i>76410</i>	—	<i>Assembly, Adapter</i>	<i>1</i>	
14	76128	S	Cylinder	1	<i>76415</i>	—	<i>Assembly, Adapter</i>	<i>1</i>	
15	—	S	Body, Discharge	1	—	76270	FPM*	<i>Kit, Seal (Incls: 6,7,16,20,24-27)</i>	<i>1</i>
16	76112	S	Ring, Retainer	1	—	76275	FPM*	<i>Kit, Valve (Incls: 9-12,18-23)</i>	<i>1</i>
17	76119	S	Screw, HSH (M6X70)	4	—	76280	CC	<i>Kit, Plunger (Incls: 2-5,8-12,18,26-28,33)</i>	<i>1</i>
18	44872	S	Spring	1	—	999204	S	<i>3-Way Ball Valve (closed center)</i>	<i>1</i>
19	46764	S	Valve	1	—	33937	SS	<i>Check Valve</i>	<i>1</i>
20	76656	FPM	O-Ring, Discharge Valve Seat - 70D	1					
21	543988	PVDF	Retainer, Spring	1					
22	545177	S	Seat	1					
23	46865	S	Spring	1					

*Italics are optional items. *Review individual parts in each kit for material identification.*

MATERIAL CODES (Not Part of Part Number): CC=Ceramic FPM=Fluorocarbon HT=High Temp NBR=Medium Nitrile (Buna-N) NY=Nylon
 PTFE=Pure Polytetrafluoroethylene PVC=Polyvinyl Chloride PVDF=Polyvinylidene Fluoride RBR=Rubber S=304SS SS=316SS

NOTE: Pulse body and inlet body must be replaced as a set.

MAINTENANCE

Pulse Pump Disassembly

1. Remove four hex socket head cap screws with a 5mm allen wrench.
2. Separate and remove discharge body from cylinder.
3. Grasp plastic spring retainer and pull valve assembly from cylinder.
4. Remove cylinder with o-rings from inlet body.
5. Separate and remove inlet body from pulse body.
6. Remove two-piece Hi-Pressure Seal from inlet body.
7. Remove large return spring.
8. Grasp end of plunger assembly and pull from pulse body.
9. To remove the M18 ceramic plunger, use a 3/8" open end wrench on the hex part of the plunger rod for support and with a 10mm open end wrench remove nut. Next remove conical washer, spring, inlet spacer, inlet valve and ceramic plunger.
10. To remove the M20 ceramic plunger, use a 3/8" open end wrench on the hex part of the plunger rod for support and with a 11mm open end wrench remove the plunger retainer. Next remove the gasket, o-ring and ceramic plunger from the plunger retainer. The retainer and spring can also be removed.
11. Remove o-ring from pulse body.
12. Turn pulse body over. Remove snap ring from threaded side of pulse body.
13. Remove two-piece Hi-Pressure Seal from pulse body.

Note: Discharge port can be orientated in 90° increments by removing the four hex socket head cap screws with a 5mm allen wrench and rotating body to desired location. Re-torque to 10 ft-lbs.

Pulse Pump Reassembly

1. Examine both Hi-Pressure Seals for wear to the internal and external surfaces and replace as needed.
2. Lubricate and place one Hi-Pressure Seal (M20) with metal backing down into threaded end of the pulse body.
3. Install retainer ring to hold Hi-Pressure Seal in place.
4. Turn pulse body over and press plunger assembly with large diameter plunger down into pulse body.
5. Examine o-ring for cuts or wear and replace as needed.
6. Place o-ring into pulse body.
7. Position large return spring over plunger assembly.
8. Place inlet body with barb end closest to pulse body. Align grooves in inlet body with tapped holes of pulse body.
9. Lubricate and place one Hi-Pressure Seal (M18) with metal backing down into the smaller hole side of the inlet body.
10. Examine o-rings for cuts or wear and replace as needed.
11. Lubricate and install one o-ring on each end of the cylinder.
12. Press cylinder into inlet body with larger hole facing down.
13. Lubricate valve seat o-ring and press complete valve assembly into small hole in cylinder.
14. Place discharge body over cylinder. Ensure mounting holes line up with grooves on inlet body and threaded holes in pulse body.
15. Thread in four hex socket head cap screws by hand. Use a 5mm allen wrench to torque to 10 ft-lbs.

Loctite® and 242® are registered trademarks of the Henkel Corporation.

World Headquarters

CAT PUMPS

1681 - 94th Lane N.E. Minneapolis, MN 55449 - 4324

Phone (763) 780-5440 — FAX (763) 780-2958

e-mail: techsupport@catpumps.com
www.catpumps.com

International Inquiries

FAX (763) 785-4329

e-mail: intlsales@catpumps.com



The Pumps with Nine Lives

CAT PUMPS (U.K.) LTD.

1 Fleet Business Park, Sandy Lane, Church Crookham
FLEET, Hampshire, GU52 8BF, England
Phone Fleet 44 1252-622031 — Fax 44 1252-626655
e-mail: sales@catpumps.co.uk www.catpumps.co.uk

N.V. CAT PUMPS INTERNATIONAL S.A.

Heiveldekens 6A, B-2550 Kontich, Belgium
Phone 32-3-450.71.50 — Fax 32-3-450.71.51
e-mail: cpi@catpumps.be www.catpumps.be

CAT PUMPS DEUTSCHLAND GmbH

Buchwiese 2, D-65510 Idstein, Germany
Phone 49 6126-9303 0 — Fax 49 6126-9303 33
e-mail: catpumps@t-online.de www.catpumps.de